

POST 1A SMF ENLARGEMENT

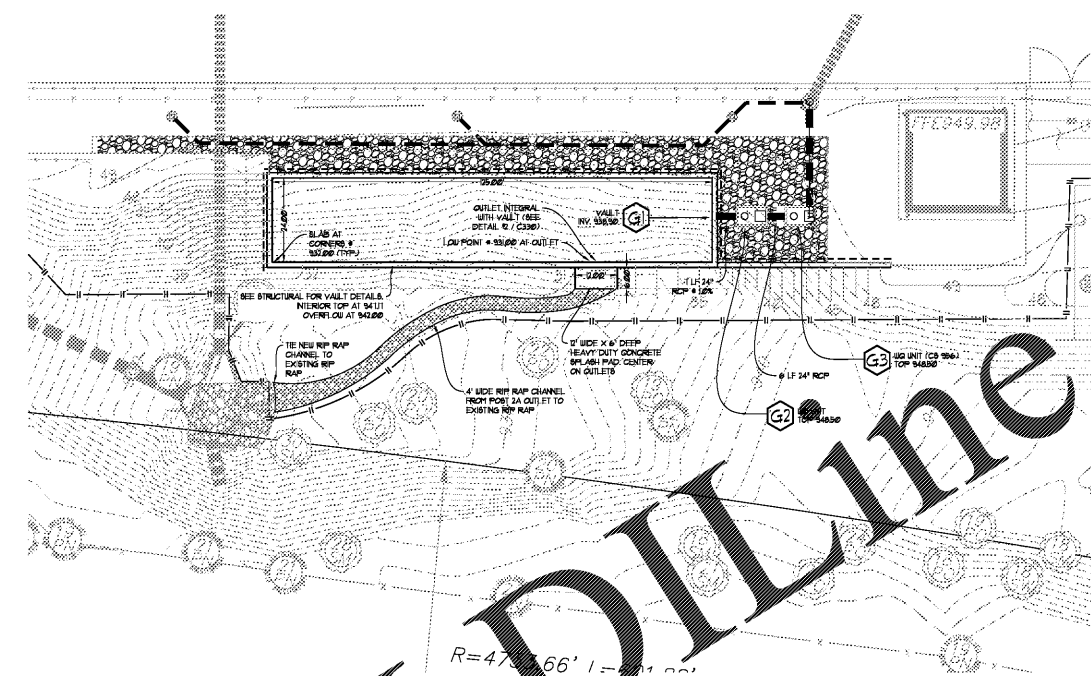

POST 2A SMF ENLARGEMENT

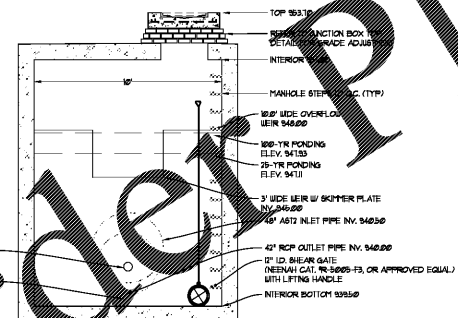
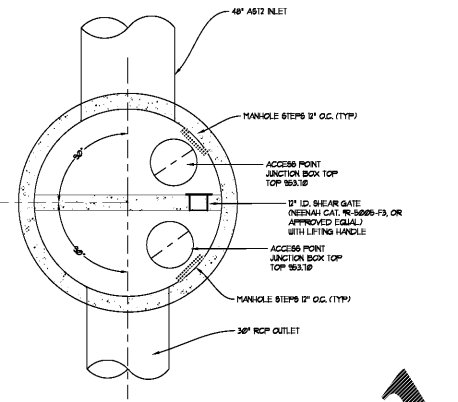

NOTES:
 1. CONTRACTOR SHALL SUBMIT SHOP DRAWINGS FOR REVIEW AND APPROVAL PRIOR TO FABRICATION.
 2. ALL CONCRETE SHALL BE MINIMUM 3000 PSI & 28 DAYS STRENGTH.
 3. STRUCTURE SHALL BE REINFORCED PER MANUFACTURER'S RECOMMENDATIONS.
 4. ALL INLET AND OUTLET PIPES SHALL BE FULLY GROUDED INSIDE AND OUT.
 5. SURROUND AND SURROUNDING FILL MATERIAL SHALL BE COMPACTED TO MINIMUM 98% PER STANDARD PROCTOR TEST.
 6. PROVIDE PAVED INSET & STRUCTURE BOTTOM.

POST 1A SMF OUTLET CONTROL STRUCTURE #A4
 NOT TO SCALE

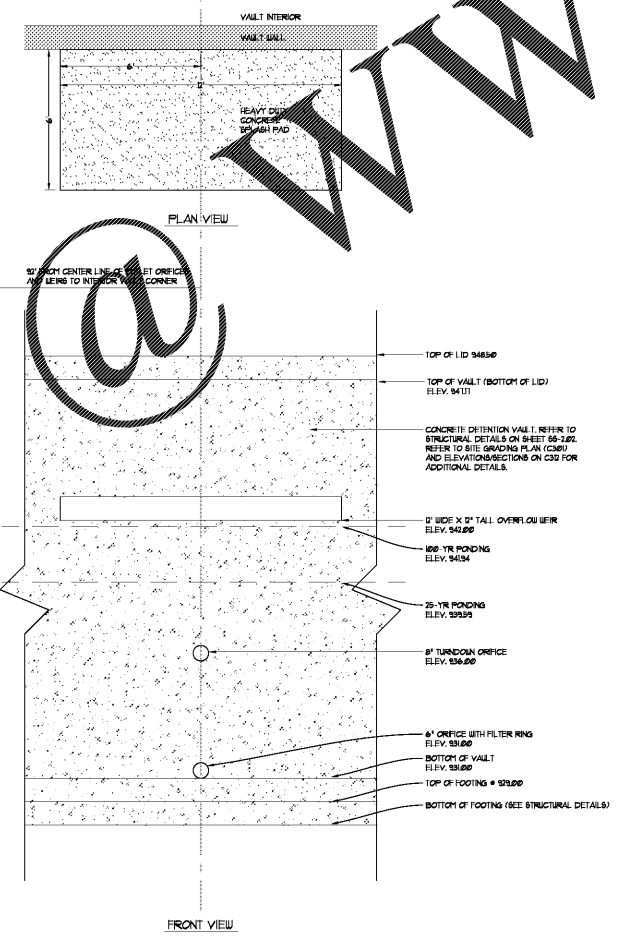

POST 2A SMF OUTLET DETAIL (IN WALL)
 NOT TO SCALE

Order Plans

WWW.LDILINE.COM

24-HR CONTACT INFORMATION
CHAD A. WORD
 FULTON COUNTY SCHOOLS
 OWNER'S REPRESENTATIVE
 470-254-3355

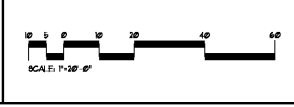

DO NOT DUPLICATE DRAWINGS WITHOUT WRITTEN PERMISSION

CAUTION

THE UTILITIES SHOWN ARE BASED ON THE CONTRACTOR'S CONVENIENCE ONLY. THERE MAY BE OTHER UTILITIES NOT SHOWN ON THESE PLANS. THE DESIGN PROFESSIONAL ASSUMES NO RESPONSIBILITY FOR THE LOCATIONS SHOWN AND IT SHALL BE THE CONTRACTOR'S RESPONSIBILITY TO VERIFY THE LOCATIONS OF UTILITIES WITHIN THE LIMITS OF THE WORK. DAMAGE TO EXISTING UTILITIES BY THE CONTRACTOR FROM THEIR OPERATIONS SHALL BE THE SOLE RESPONSIBILITY OF THE CONTRACTOR.

811 Know what's below.
 Call before you dig.
 Dial 811
 Or Call 800-282-7411

CONTRACTOR SHALL BE RESPONSIBLE TO OBTAIN THE SERVICES OF A PRIVATE UTILITY LOCATOR PRIOR TO THE START OF CONSTRUCTION. CONTRACTOR SHALL PAY FOR SAID SERVICES. CONTRACTOR SHALL IMMEDIATELY REPAIR ALL UTILITIES DAMAGED BY CONSTRUCTION ACTIVITIES, AT NO ADDITIONAL COST TO THE OWNER.

CONTRACTOR SHALL BE RESPONSIBLE FOR COMPACTION OF BACKFILL OF ALL UTILITY TRENCHES WITHIN THIS WORK. THIS INCLUDES TRENCHES DUG AND BACKFILLED BY LOCAL UTILITIES, SUCH AS POWER, GAS, TELEPHONE, ETC. CONTRACTOR SHALL PROVIDE ADDITIONAL BACKFILL AND COMPACTION AS NECESSARY, IF SETTLEMENT OCCURS.



CGLS ARCHITECTS
 CHAPMAN GRIFFIN LANIER SUSSENBACH ARCHITECTS
 400 Galleria Pkwy., Suite 100 • Atlanta, Ga 30339 • Phone: 404.733.5493



BREEDLOVE LAND PLANNING
 1115 W. BROAD ST. SUITE 200
 ATLANTA, GA 30308



GEORGIA REGISTERED PROFESSIONAL ENGINEER
 CHAD A. WORD
 LICENSE NO. 12102
 12/02/2018

DATE	NO.	DESCRIPTION
03/28/18		CODE PRELIMINARY SUBMITTAL / DESIGN DEVELOPMENT
06/18/18		CODE PRELIMINARY SUBMITTAL / DESIGN DEVELOPMENT
08/13/18		CODE CHECK SET / FIRM SET
10/10/18		FINAL CODE SUBMITTAL
11/01/18		ISSUED FOR PROPOSALS

RIVERWOOD HIGH SCHOOL - PHASE 3-8
AUDITORIUM/GYMNASIUM ADDITION

5800 RAIDER DRIVE NW SANDY SPRINGS, GA 30228
 FULTON COUNTY SCHOOLS RFP NO. 411-19

CHAPMAN GRIFFIN LANIER SUSSENBACH ARCHITECTS

STORMWATER ENLARGEMENTS & OCS DETAILS

PROJECT NO: 16015.02
 DATE: 09.17.18
 DRAWN BY: KWW
 CHECKED BY: HCB

C-330