

Order Plans

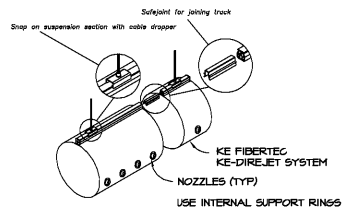

SafeTrack 360° Suspension Detail

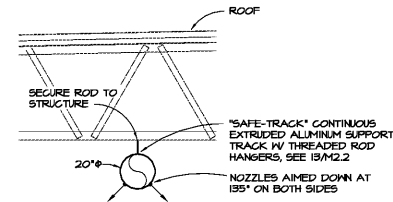

SECTION AT FABRIC DUCT

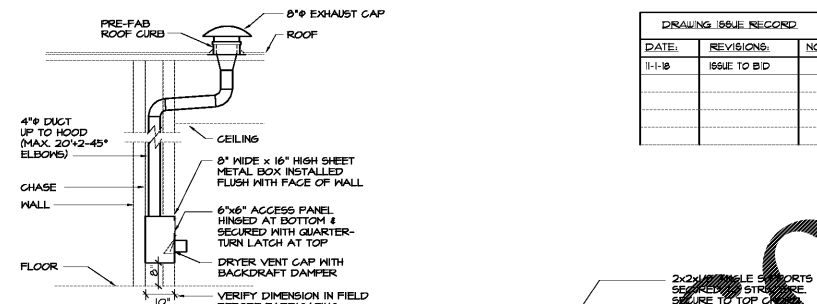

DRYER VENT DETAIL

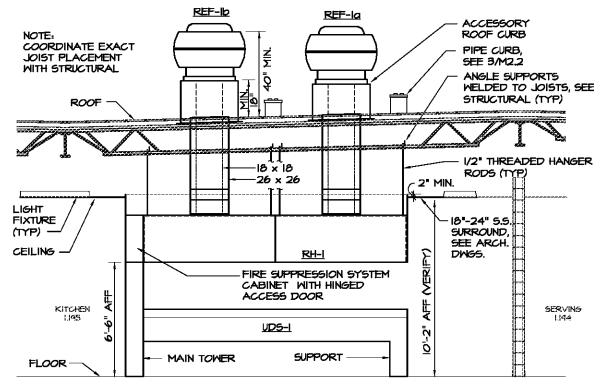

SECTION AT RANGEHOOD

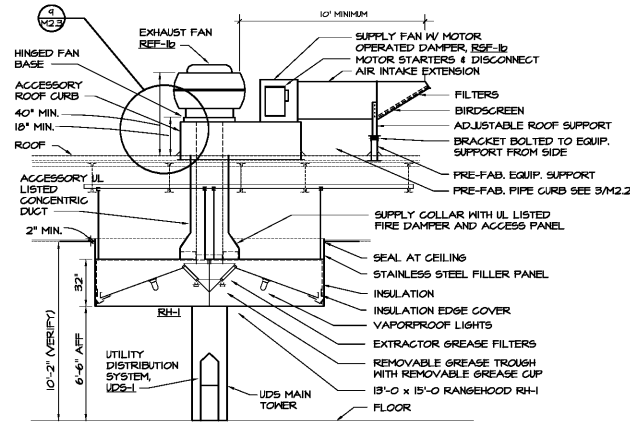

- NOTES: 1. RANGEHOOD SHALL BE UL LISTED AND COMPLY WITH NFPA 96.
 2. FIRE SUPPRESSION SYSTEM SHALL BE PROVIDED IN ACCORDANCE WITH NFPA 17A.
 3. INSTALL BAKELITE LABEL (WITH 1\"/>

SECTION AT RANGEHOOD

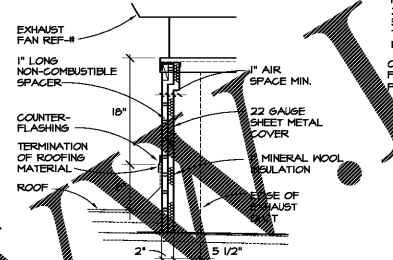

SECTION @ REF CURBS

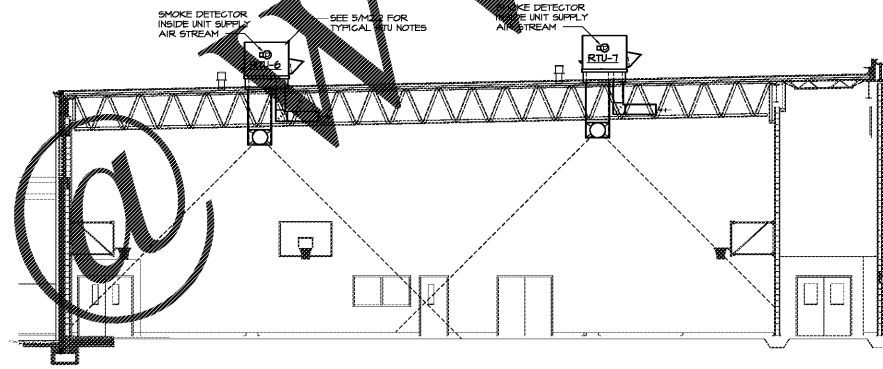

SECTION @ GYM

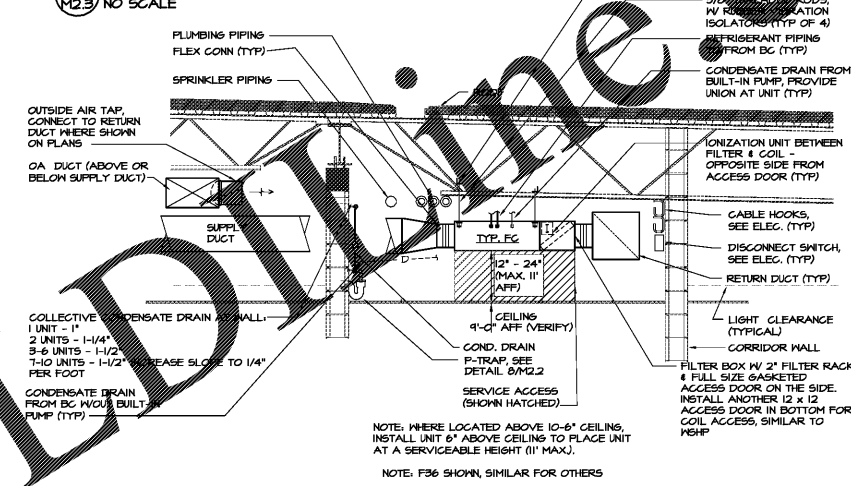

SECTION AT VRF FAN-COIL UNIT

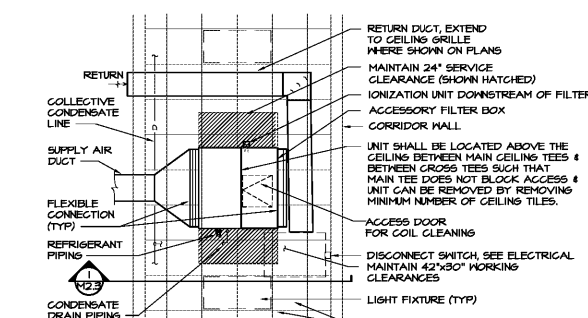

PARTIAL PLAN AT TYPICAL VRF FAN-COIL UNIT

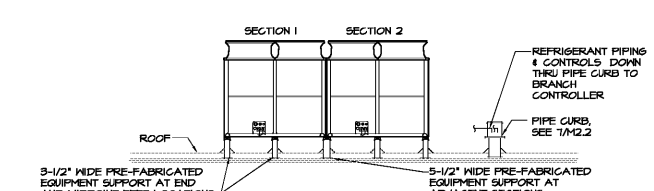

SECTION AT TYPICAL VRF HEAT PUMP ON ROOF

DATE	REVISIONS	NO.
11-1-18	ISSUE TO B'D	

HARMONY ELEMENTARY SCHOOL
 REPLACEMENT ELEMENTARY SCHOOL
 6528 FACTORY SCHOOLS BLVD., NW
 MABLETON, GA 30126
 FOR COBB COUNTY SCHOOL DISTRICT
 COBB COUNTY, GA
 CCSD PROJECT NO. ADDR / DDE FACILITY CODE
 DATE: JULY 16, 2019
 DRAWN BY: C.F.A./R.L.Y.
 CUNNINGHAM, FOREHAND, MATTHEWS & MOORE, ARCHITECTS, INC. - 2011 manchester street, n.e. - atlanta, georgia 30324 - phone (404) 873-2152
 SPURLOCK & ASSOCIATES, INC. consulting engineers
 2970 Clairmont Rd., Suite 420 | Atlanta, GA 30329
 P: 404.433.0245 | F: 404.433.1756
 JOB NO. 1822

cunningham forehand matthews moore

M2.3



DO NOT DUPLICATE WITHOUT PERMISSION