

Order Plans @

WWW.LDLine.com

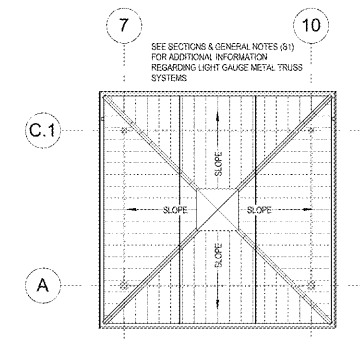

3 TOWER TRUSS FRAMING PLAN
1/2" = 1'-0"

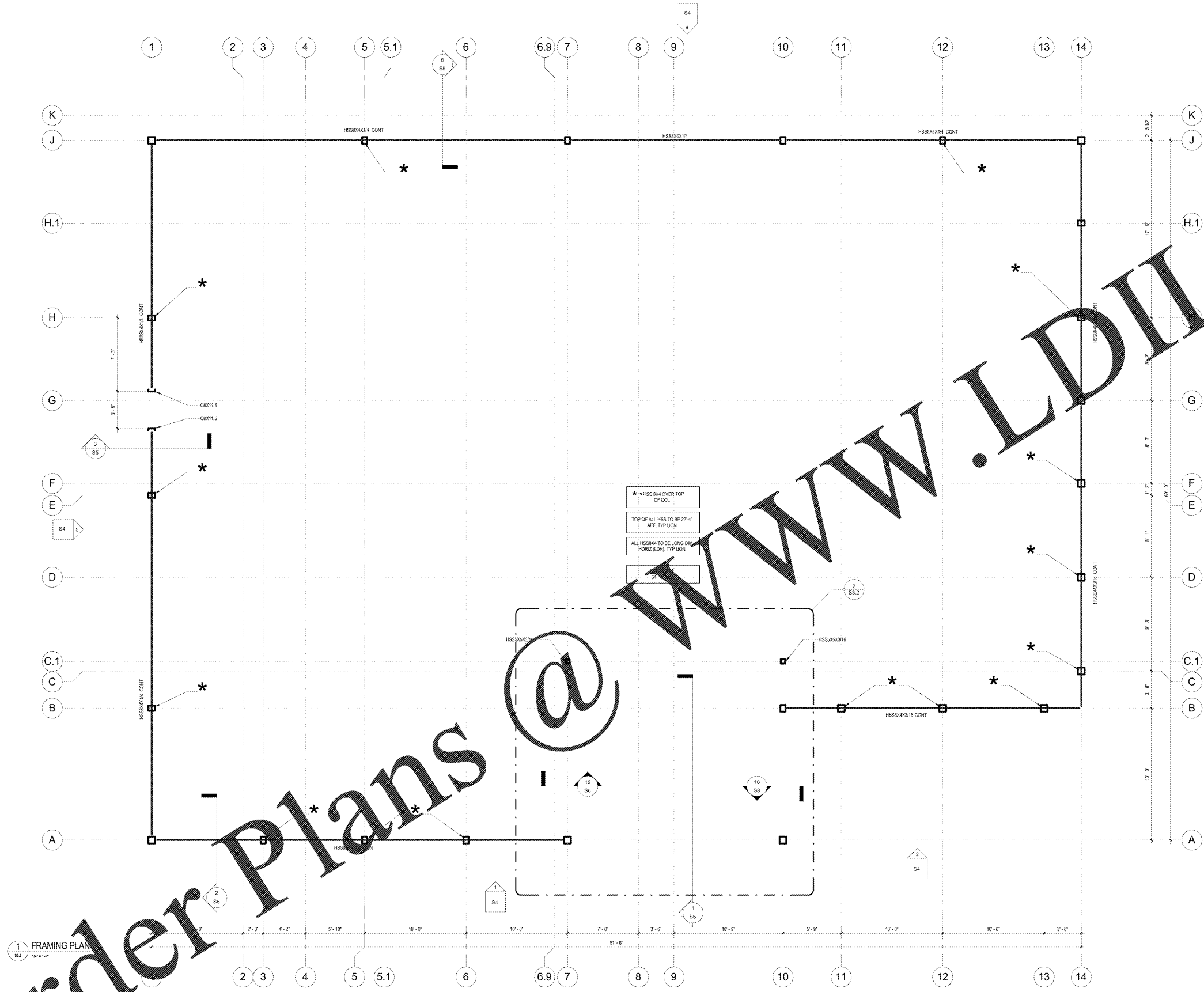
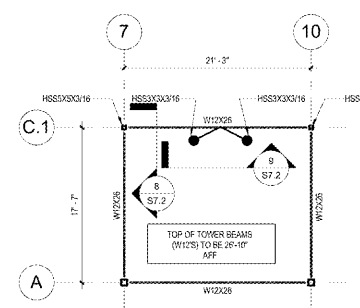

2 TOWER FRAMING PLAN
1/2" = 1'-0"

1 FRAMING PLAN
1/2" = 1'-0"

CLIENT NAME
WAWA
 260 WEST BALTIMORE PIKE
 WAWA, PENNSYLVANIA 19063

PROJECT NAME
WAWA F85FB 2018.01 STORE #5275-LIT
 9021 STATE ROAD 62
 HUDSON, FL 34689

Revisions Schedule	
No.	Date
1	03/21/2017
2	03/24/2017
3	03/24/2017
4	03/24/2017
5	03/24/2017
6	03/24/2017
7	03/24/2017
8	03/24/2017
9	03/24/2017
10	03/24/2017
11	03/24/2017
12	03/24/2017
13	03/24/2017
14	03/24/2017
15	03/24/2017
16	03/24/2017
17	03/24/2017
18	03/24/2017
19	03/24/2017
20	03/24/2017
21	03/24/2017
22	03/24/2017
23	03/24/2017
24	03/24/2017
25	03/24/2017
26	03/24/2017
27	03/24/2017
28	03/24/2017
29	03/24/2017
30	03/24/2017
31	03/24/2017
32	03/24/2017
33	03/24/2017
34	03/24/2017
35	03/24/2017
36	03/24/2017
37	03/24/2017
38	03/24/2017
39	03/24/2017
40	03/24/2017
41	03/24/2017
42	03/24/2017
43	03/24/2017
44	03/24/2017
45	03/24/2017
46	03/24/2017
47	03/24/2017
48	03/24/2017
49	03/24/2017
50	03/24/2017

S3.2

LD Line
 Design & Peterson
 Engineers Planners
 Architects
 1800 West Alamo Avenue
 Suite 100
 Houston, TX 77058
 Phone: 281.441.1111
 Fax: 281.441.1112
 www.ldline.com