

NOTE:
FOR TYPICAL EXTERIOR
WALL CONSTRUCTION
NOTATION, REFER
A3.1

GENERAL NOTES

- (A) REFER TO PROJECT MANUAL AND SCOPE OF WORK SCHEDULE FOR ADDITIONAL REQUIREMENTS.
- (B) REFER TO CIVIL, STRUCTURAL, MECHANICAL, ELECTRICAL, PLUMBING, AND PRE-ENGINEERED METAL BUILDING (P.E.M.B.) SHOP DRAWINGS FOR ADDITIONAL REQUIREMENTS.
- (C) REFER TO INTERIOR AND EXTERIOR FINISH SCHEDULES FOR MATERIAL TYPES, COLORS AND FINISHES.
- (D) DIMENSIONS ARE TO FACE OF CONCRETE, FRAMING OR CENTERLINE OF STRUCTURE UNLESS OTHERWISE INDICATED.
- (E) NOT ALL INSULATION SHOWN FOR CLARITY.

KEY NOTES

- (1) PRE-ENGINEERED METAL BUILDING EXTERIOR WALL PANEL SYSTEM.
- (2) PRE-ENGINEERED METAL BUILDING PRIMARY AND SECONDARY STRUCTURAL FRAMING SYSTEMS.
- (3) PRE-ENGINEERED METAL BUILDING SHEET METAL FLASHING, GUTTER, DOWNSPOUT, CONTINUOUS CLEATS, DRIPS CLOSURES, TRANSITIONS, COPINGS AND ACCESSORIES AS REQUIRED.
- (4) PRE-ENGINEERED METAL BUILDING GUTTER AND DOWNSPOUT SYSTEM, REFER TO EXTERIOR. REFER TO P.E.M.B. SHOP DRAWINGS FOR SIZES.
- (5) PRE-ENGINEERED METAL BUILDING BASE ANGLE OR GIRT WITH PANEL CLOSURE AND SEALANT SYSTEM.
- (6) PRE-ENGINEERED METAL BUILDING INTERIOR WALL LINER PANEL.
- (7) PRE-ENGINEERED METAL BUILDING ROOF PANEL SYSTEM WITH THERMAL SPACER BLOCKS (R-5 MIN.).
- (8) PRE-ENGINEERED METAL BUILDING SOFFIT PANEL SYSTEM OR FIELD FABRICATED SHEET METAL CLADDING SYSTEM TO MATCH FRONT EXTERIOR WALL PANELS. REFER TO PEBS DRAWINGS FOR REQUIREMENTS.
- (9) PRE-ENGINEERED METAL BUILDING ROOF INSULATION (R-35) LINER SYSTEM, (REFER TO SCOPE OF WORK SCHEDULE), VAPOR BARRIER OVER HIGH STRENGTH STEEL SUSPENSION STRAPS ATTACHED TO BOTTOM OF PRE-ENGINEERED METAL BUILDING ROOF PURLINS WITH (1) LAYER 8" (R-25) UN-FACED BATT INSULATION PARALLEL WITH ROOF PURLIN CAVITY AND (1) LAYER 3 1/2" (R-11) UN-FACED BATT INSULATION PERPENDICULAR OVER TOP OF ROOF PURLINS.
- (10) PRE-ENGINEERED METAL BUILDING WALL INSULATION (R-13) WITH VAPOR BARRIER SYSTEM, (REFER TO SCOPE OF WORK SCHEDULE).
- (11) BATT INSULATION (R-19) WITH FOIL FACE VAPOR BARRIER (CONTRACTOR FURNISHED AND INSTALLED).
- (12) ALUMINUM WINDOW SYSTEM. REFER TO FLOOR PLAN AND WINDOW SCHEDULES FOR TYPES.
- (13) PRE-FINISHED SHEET METAL (24 GA.) COLUMN ENCLOSURE TO EXTEND THRU FINISH CEILING SYSTEM. COLOR TO MATCH WINDOW FRAMING FINISH.
- (14) SUSPENDED ACOUSTICAL LAY - IN CEILING SYSTEM. REFER TO INTERIOR FINISH SCHEDULE FOR TYPES AND LOCATIONS.
- (15) 6" (18 GA.) COLD FORM METAL STUD FRAMING AT 24" O.C. ATTACHED TO PRE-ENGINEERED METAL BUILDING STRUCTURAL FRAMING SYSTEM. REFER TO STRUCTURAL DRAWINGS.
- (16) 5/8" TYPE "X" GYPSUM BOARD (PAINT).
- (17) SURFACE MOUNTED WALL SIGN, OWNER FURNISHED AND INSTALLED. (REFER TO SCOPE OF WORK SCHEDULE), PROVIDE BACKING AND ELECTRICAL ROUGH-IN, REFER TO ELECTRICAL DRAWINGS.
- (18) (NOT USED).
- (19) FIRE TREATED 2X BLOCKING ATTACHED TO PRE-ENGINEERED METAL BUILDING STRUCTURAL SYSTEM.
- (20) (NOT USED).
- (21) RECESSED LIGHTING FIXTURE, REFER TO ELECTRICAL DRAWINGS FOR TYPE AND LOCATION.
- (22) FLOORING AND BASE. REFER TO INTERIOR FINISH SCHEDULE FOR TYPES AND LOCATIONS.
- (23) 3/8" (20 GA.) COLD FORM METAL STUD FRAMING AT 24" O.C., REFER TO FLOOR PLAN AND INTERIOR WALL TYPES.
- (24) NOT USED.
- (25) PRE-ENGINEERED METAL BUILDING TRANSITION SUPPORT BENT PLATE.
- (26) DOOR AND FRAME SYSTEM, REFER TO FLOOR PLAN AND SCHEDULES FOR TYPES.
- (27) FINISH LAWN, PAVEMENT OR SIDEWALK, SLOPE TO DRAIN AWAY FROM BUILDING. REFER TO CIVIL DRAWINGS.
- (28) CAULK: COLOR TO MATCH METAL PANEL COLOR ABOVE.
- (29) FIBER CEMENT PANELS: (REFER TO ELEVATIONS FOR ADDITIONAL INFORMATION).
- (30) PARAPET POST: REFER TO P.E.M.B. NOTES AND SHOP DRAWINGS FOR REQUIREMENTS.

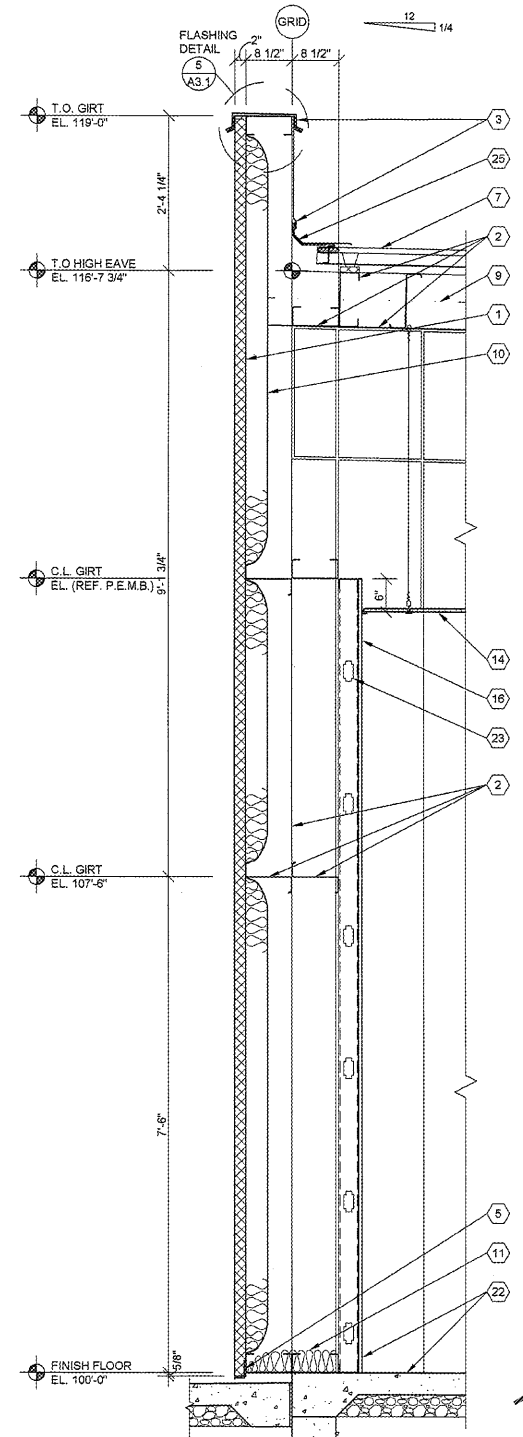

1 WALL SECTION
A3.1 SCALE: 3/4" = 1'-0"

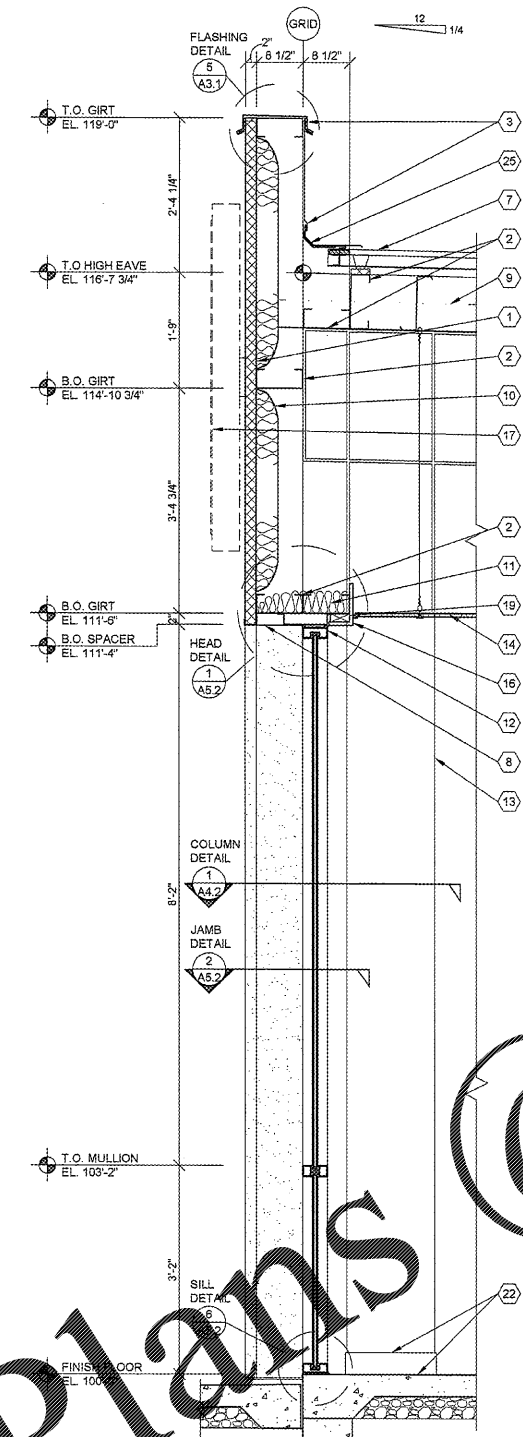

2 WALL SECTION
A3.1 SCALE: 3/4" = 1'-0"

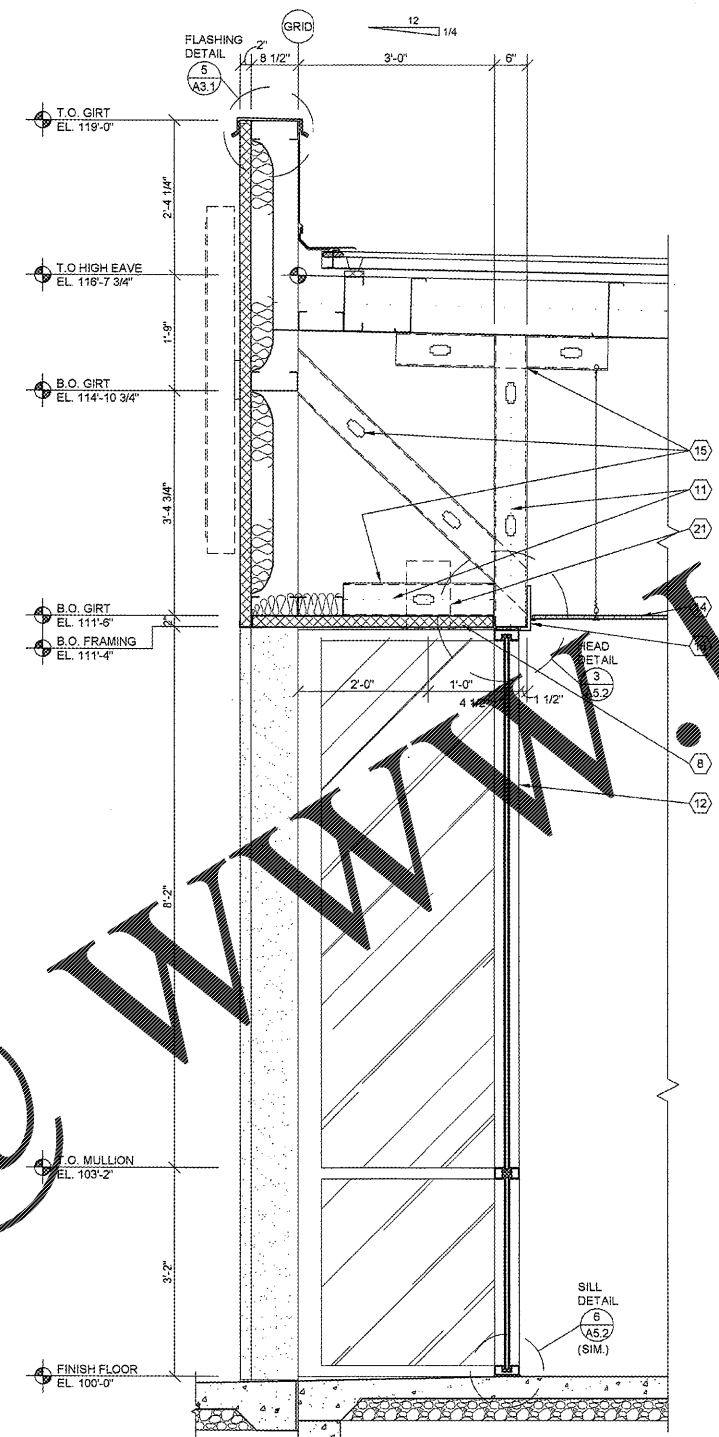

3 WALL SECTION
A3.1 SCALE: 3/4" = 1'-0"

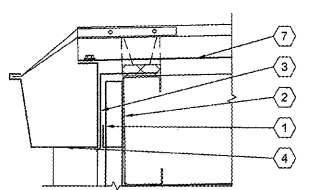

4 SECTION
A3.1 SCALE: 1 1/2" = 1'-0"

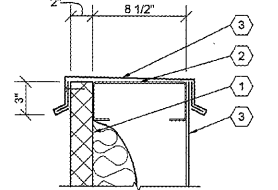

5 SECTION
A3.1 SCALE: 1 1/2" = 1'-0"

NOTE:
REFER TO STRUCTURAL DRAWINGS FOR FOOTINGS,
FOUNDATIONS, SLABS AND REINFORCEMENT.

Order Plans @

WWW.LDILINE.COM

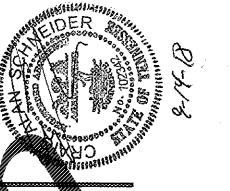

1756 East Sunshine Suite 400
Springfield, Missouri 65804
417-862-3206
417-862-0658
Fax: 417-862-3206
e-mail: architect@esterlyschneider.com

ESTERLY SCHNEIDER & ASSOCIATES, INC.
AIA architects & planners

PROJECT:
NEW O'REILLY AUTO PARTS STORE
U.S. HWY 64
SOMERVILLE, TN
WALL SECTIONS

O'Reilly AUTO PARTS
CORPORATE OFFICES
233 SOUTH PATTERSON
SPRINGFIELD, MISSOURI 65802
(417) 862-2674 TELEPHONE

COMM #	4231
DATE:	9-11-18
REVISION	
DATE:	