

**1 SECTION**  
S3.1 SCALE: 3/4" = 1'-0"

**2 SECTION**  
S3.1 SCALE: 3/4" = 1'-0"

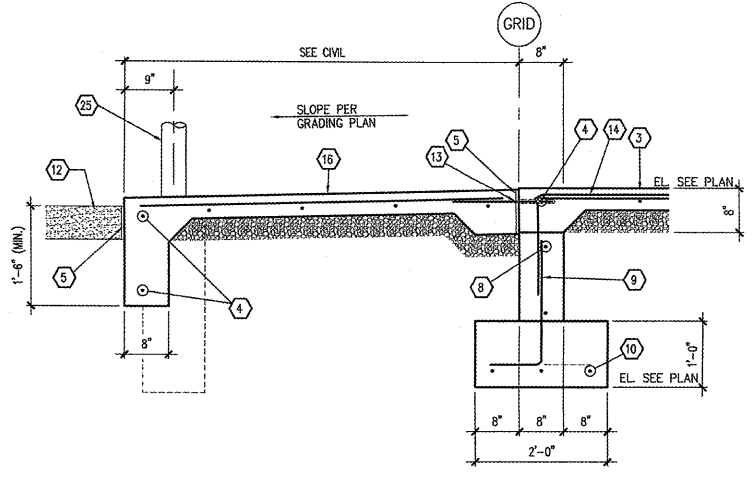

**3 SECTION**  
S3.1 SCALE: 3/4" = 1'-0"

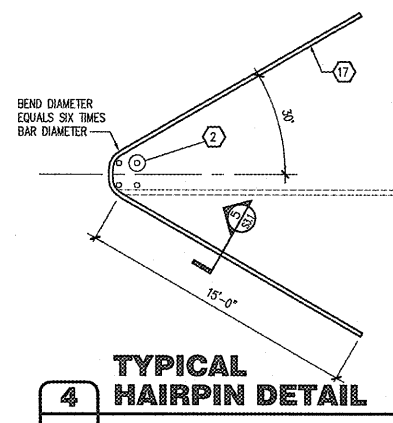

**4 TYPICAL HAIRPIN DETAIL**  
S3.1 SCALE: NONE

**KEYNOTES**

- 1 PRE-ENGINEERED METAL BUILDING STRUCTURAL SYSTEM. SEE P.E.M.B. SHOP DRAWINGS FOR ADDITIONAL INFORMATION.
- 2 ANCHOR BOLTS. SEE FOUNDATION SCHEDULE AND PRE-ENGINEERED METAL BUILDING DRAWINGS FOR SIZE, QUANTITY AND PLAN LOCATION. SEE 1/S3.2 FOR TYPICAL SHOP FABRICATED ANCHOR ASSEMBLY.
- 3 INTERIOR CONCRETE SLAB SEE FOUNDATION PLAN.
- 4 #4 CONTINUOUS
- 5 1/2" ISOLATION JOINT WITH ASPHALTIC FILLER & SEALANT
- 6 ADDITIONAL #4 CONTINUOUS
- 7 CONTINUOUS RUSTICATION JOINT
- 8 #4's CONTINUOUS AT 12" O.C.
- 9 #4 BENT DOWELS @ 18" O.C. SEE HOOK AS SHOWN
- 10 (3) #4's CONTINUOUS
- 11 SEE GRADING PLAN FOR FINISHED GRADES.
- 12 PAVEMENT SEE SITE DEVELOPMENT DRAWINGS FOR ADDITIONAL INFORMATION.
- 13 AT ENTRY LOCATIONS, DRILL 6" DEEP HOLES FOR #4x1'-6" DOWELS @ 24" O.C. DRILL AND PLACE INTO FOUNDATION. FOLLOW ADHESIVE INSTRUCTIONS SPECIFIED BY MANUFACTURER.
- 14 #3x5'-0" DOWEL @ 36" O.C. FIELD BEND AS SHOWN 24"
- 15 EN CONCRETE SLAB, SEE PLAN.
- 16 EXTERIOR CONCRETE SLAB OR SIDEWALK SEE FOUNDATION PLAN. REFER TO SITE DEVELOPMENT DRAWINGS FOR ALL EXTERIOR TOP OF CONCRETE ELEVATIONS.
- 17 #5 SLAB HAIRPIN. SEE DETAIL 4/S3.1
- 18 (3) #3 TIES @ 12" O.C.
- 19 #3 TIES @ 12" O.C.
- 20 #4 BENT DOWELS @ 18" O.C.
- 21 STEM WALL AND FOOTING REINFORCEMENT TO RUN CONTINUOUS THROUGH COLUMN PILASTERS AND SPREAD FOOTINGS.
- 22 LINE OF STEM WALL AND FOOTING BEYOND
- 23 SEE FOUNDATION SCHEDULE FOR FOOTING & PILASTER REINFORCEMENT.
- 24 #4 DOWELS @ 18" O.C.
- 25 STEEL BOLLARD SEE SITE PLAN.
- 26 REFER TO SECTIONS FOR REBAR TIE SIZE AND SPACING.
- 27 #4 CORNER REINFORCEMENT TO MATCH STEM WALL BAR SPACING.
- 28 (5) #4's CONTINUOUS
- 29 #3x5'-6" DOWEL @ 30" O.C. FIELD BEND AS SHOWN 30"

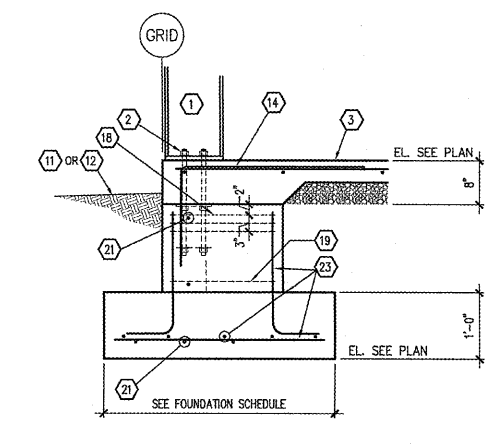

**6 SECTION**  
S3.1 SCALE: 3/4" = 1'-0"

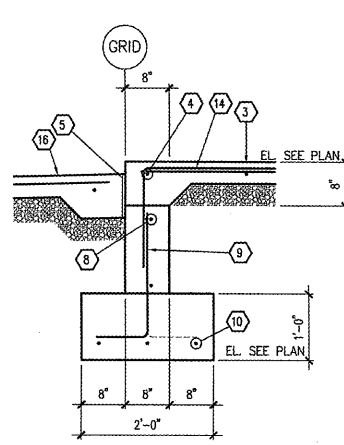

**7 SECTION**  
S3.1 SCALE: 3/4" = 1'-0"

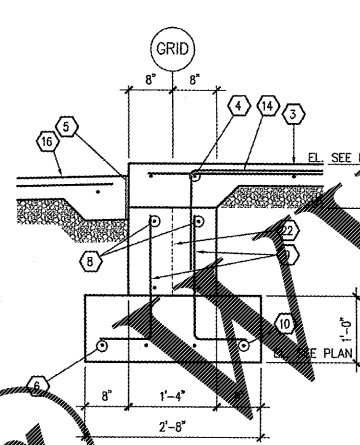

**8 SECTION**  
S3.1 SCALE: 3/4" = 1'-0"

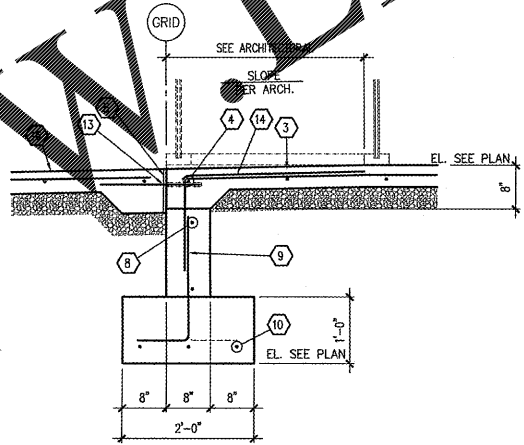

**9 SECTION**  
S3.1 SCALE: 3/4" = 1'-0"

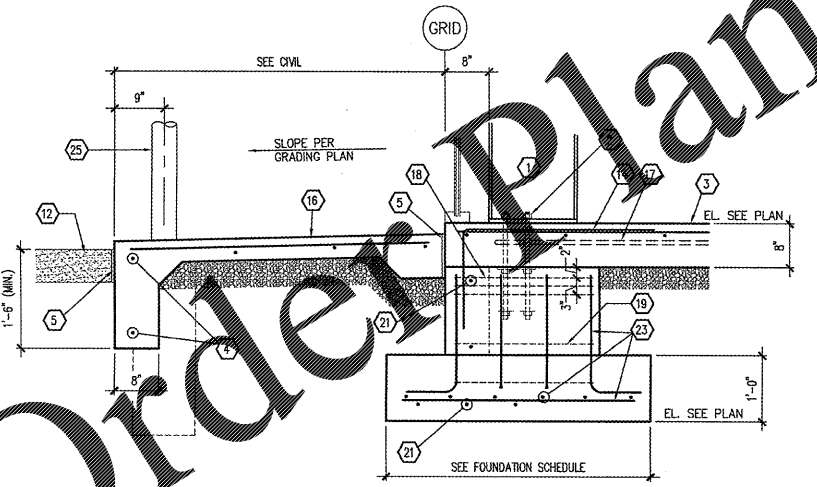

**10 SECTION**  
S3.1 SCALE: 3/4" = 1'-0"

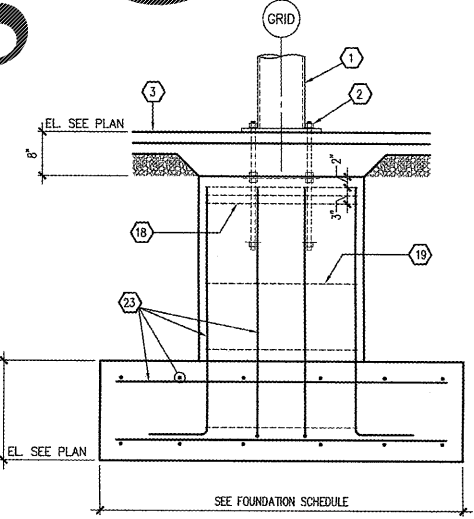

**11 SECTION**  
S3.1 SCALE: 3/4" = 1'-0"

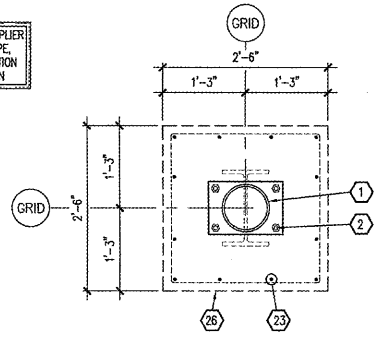

**12 DETAIL**  
S3.1 SCALE: 3/4" = 1'-0"

REFER TO PEMB SUPPLIER FOR COLUMN SHAPE, SIZE, AND ORIENTATION AT THIS LOCATION

Order Plans



1726 East Sunshine Ave #17  
Springfield, Missouri 65804  
417.862.2674  
FAX: 417.862.2675  
e-mail: architect@estertyschneider.com

**ESTERY SCHNEIDER & ASSOCIATES, INC.**  
architects & planners  
AIA

PROJECT:  
**NEW O'REILLY AUTO PARTS STORE**  
U.S. HWY 64  
SOMERVILLE, TN  
**FOUNDATION DETAILS**

**O'Reilly AUTO PARTS**  
CORPORATE OFFICES  
233 SOUTH PATTERSON  
SPRINGFIELD, MISSOURI 65802  
(417) 862-2674 TELEPHONE

COMM # 4231  
DATE: 9-11-18  
REVISION  
DATE:

**J.S. Smith Consulting**  
Aaron D. Smith P.E. 00107193  
1801 W 32nd St. Bldg B Ste 104 \* JOPLIN, MISSOURI 64804  
P.O. Box 8102 \* JOPLIN, MISSOURI 64802  
PHONE: 417-624-0444 \* FAX: 417-624-0430