

ENLARGED ROOF PLAN

3/8"

LIGHTING FIXTURE SCHEDULE			
12	ECOSENSE 07AC-27-120-22-BK LF16/L3 LENS	LAMP INCLUDED (15.25 WATTS)	EAVE MOUNTED, BLACK FINISH ANGLED TO WASH SIDE OF TOWER. PROVIDE (06) SPREAD LENS FILM - PACKAGED SEPARATELY, TO BE INSTALLED BY G.C.
10	PROGRESS LIGHTING P5644-20	PHIPS ENCLOSED PAR20 DIMMABLE FLOOD LED LAMP 20 DEGREE BEAM SPREAD, 2700 KELVIN LAMP ORDER CODE: [2]8PAR20/EN0/P252700/DIM	MUST INCLUDE (1) #8797-31 LENS, ONLY USE ON TOP OF FIXTURE.
16	ECOSENSE W01M-27-120-IC-BK-11 W5H-1M-1SD-10480	LAMP INCLUDED (40.92 WATTS)	FIXTURE SHALL BE PAINTED TO MATCH ROOF. PROVIDE (06) SPREAD LENS FILM - PACKAGED SEPARATELY, TO BE INSTALLED BY G.C.
11	CLARKE LIGHTING R83-3P5D-14KED-LFAR16FL-MA/BLK- EB-NIC-27K (EMERGENCY LIGHTING CAPABILITY)	LAMP INCLUDED (14 WATTS)	FIXTURE TO BE MOUNTED TO TOWER CANOPY RATED FOR DAMP LOCATIONS

REFL. CLG. PLAN KEY NOTES			
1	NOT USED.	7	NOT USED.
2	2x6 RAFTERS AND TEXTURE 1/2" PLYWOOD WITH GROOVES AT 4'-0" O.C. GROOVES SHALL RUN PERPENDICULAR TO THE RAFTERS. PAINT. (C)	8	NEW WALL LIGHTS TIED INTO EXISTING EXTERIOR LIGHTING CIRCUIT (1/25 MIN. OR MATCH EXISTING IF LARGER). MOUNT AT 8'-0" A.F.F. PROVIDE (1) #8797-31 LENS TO BE USED ON TOP OF FIXTURE ONLY. REFER TO LIGHTING FIXTURE SCHEDULE AND DETAIL 3/ A3.2.
3	NOT USED.	9	NOT USED.
4	NOT USED.	10	NEW SIGN CONNECTION. CONNECT TO EXISTING CIRCUIT. EXTEND CONDUIT AND WIRING FROM SIGN BEING REMOVED.
5	NEW EAVE MOUNTED MONOPOINT LIGHT ANGLED TO WASH SIDE OF TOWER. PROVIDE NEW J-BOX AND POSITION SO THAT FIXTURE WILL BE AGAINST BACK OF FASCIA AS SHOWN. REFER TO LIGHTING FIXTURE SCHEDULE AND DETAIL 2/ A3.2.	11	NOT USED.
6	NOT USED.	12	NOT USED.
		13	NOT USED.
		14	OUTLINE OF NEW ENTRY CANOPY BELOW.
		15	PROVIDE NEW LIGHT FIXTURE AT ENTRY CANOPY BELOW. REFER TO LIGHTING FIXTURE SCHEDULE AND DETAIL 3/ A3.2.

ENLARGED ROOF PLAN NOTES

- 1 LINE OF EXST. BUILDING (BELOW).
- 2 NOT USED.
- 3 BUILDING SIGNAGE FURNISHED AND INSTALLED BY OTHERS. G.C. TO PROVIDE ALL REQUIRED BLOCKING AND FRAMING TO HANG SIGNAGE PER MANUF. RECOMMENDATIONS.
- 4 EXST. PARAPET TO REMAIN.
- 5 EXISTING ROOF TO REMAIN.
- 6 EXISTING SKYLIGHT TO REMAIN.
- 7 PORTION OF EXISTING METAL ROOF TO BE REMOVED AS REQUIRED.
- 8 NOT USED.
- 9 EXISTING SLOPED METAL ROOF TO REMAIN.
- 10 NEW STANDING SEAM METAL ROOF. REFER TO SPECIFICATIONS AT SHEET A3.5.
- 11 6" HALF ROUND METAL GUTTER, PAINTED CLINTON BROWN (P-13). REFER TO WALL SECTIONS.
- 12 3" ROUND METAL DOWNSPOUT, PAINTED CLINTON BROWN (P-13). RIN DOWN AT FACE OF PARAPET WALL AND EMPTY ONTO ROOF. REFER TO WALL SECTIONS.
- 13 REMOVE PORTION OF OVERHANG AS REQUIRED. REPAIR DAMAGED AREAS. COORDINATE WITH OWNER.
- 14 EXISTING AWNING TO BE REMOVED. REPAIR DAMAGED AREAS. MATCH EXISTING FINISHES.
- 15 NEW ROOF LIGHT FIXTURE. PROVIDE AN ELECTRICAL CONNECTION. REFER TO DETAIL 4 / A3.2.
- 16 EXST. ROOF LIGHT TO BE REMOVED AS REQUIRED.
- 17 NEW CANOPY. REFER TO 8/ A3.2.
- 18 EXISTING SIGN TO BE REMOVED AS REQUIRED.
- 19 NOT USED.
- 20 EXISTING GUTTER & DOWNSPOUT, PAINT (P-13).

ALL NEW ROOFING WORK TO BE PERFORMED BY ORIGINAL ROOFING CONTRACTOR IN ORDER TO MAINTAIN WARRANTY.

NOT USED

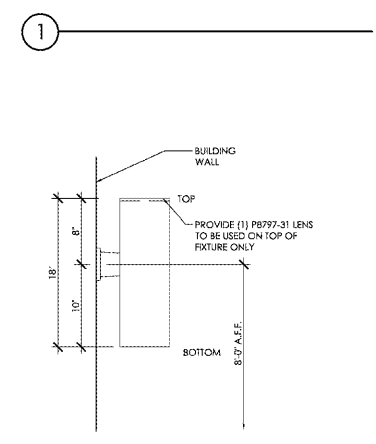

3 LIGHT FIXTURE DETAIL N.T.S.

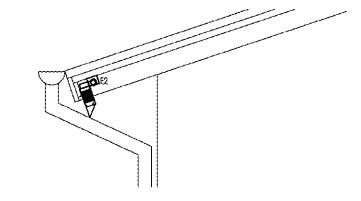

2 LIGHT MOUNTING DETAIL N.T.S.

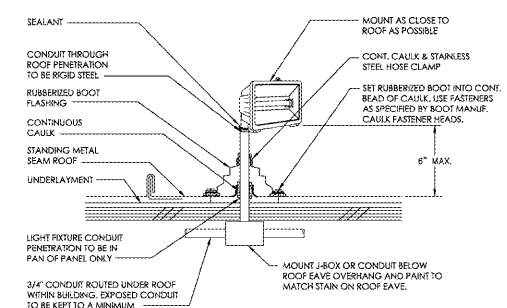

4 NEW ROOF LIGHT N.T.S.

Order Plans @ WWW.ONLINE.COM

EXTERIOR REFLECTIVE CEILING PLAN 3/16"

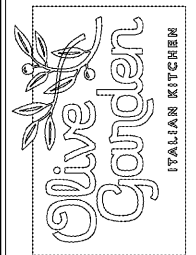

Architects
 ARCHITECTS PROJECT #:
 17-0363

Issue Date: 04-19-2018
 REVISION INFORMATION
 1
 2
 3
 4
 5
 6
 7
 8
 Restaurant #: 1343
 P1B (MEDIUM)
 2782 WILMA RUDOLPH BLVD.
 CLARKSVILLE, TN
 Drawing
EXTERIOR CEILING & ROOF PLAN
A3.2