

DOOR & FRAME SCHEDULE

DOOR NO.	DOORS				FRAMES				COMMENTS
	TYPE	DESCRIPTION	SIZE	FINISH	TYPE	FINISH	FIRE RATING	HARDWARE	
100	EX. B	ALUMINUM / GLASS	FAIR 3'-0" X 6'-8"	EX TO REMAIN	ALUMINUM	EX TO REMAIN	-	A, C, F, H, I	EX. TO REMAIN. G.C. TO VERIFY EX. HARDWARE MATCHES SET LISTED. IF NOT, PROVIDE APPROPRIATE HARDWARE AS SCHED.
100A	C	SOLID CORE WOOD	3'-0" X 6'-8"	9TH	EXISTING	PT-1	-	A, C, F, H, I	
100B	C	SOLID CORE WOOD	3'-0" X 6'-8"	9TH	EXISTING	PT-1	-	A, C, F, H, I	
101	A	SOLID CORE WOOD	3'-0" X 6'-8"	9TH	EXISTING	PT-1	-	A, B, G, I, J	
102	A	SOLID CORE WOOD	3'-0" X 6'-8"	9TH	EXISTING	PT-1	-	A, D, H, I, L	
102A	A	EXISTING	3'-0" X 4'-8" SUSPENDED	9TH	EXISTING	PT-1	-	A, D, E	EX. TO REMAIN. G.C. TO VERIFY EX. HARDWARE MATCHES SET LISTED. IF NOT, PROVIDE APPROPRIATE HARDWARE AS SCHED.
103	A	SOLID CORE WOOD	3'-0" X 6'-8"	9TH	EXISTING	PT-1	-	A, C, F, H, I	EX. TO REMAIN. G.C. TO VERIFY EX. HARDWARE MATCHES SET LISTED. IF NOT, PROVIDE APPROPRIATE HARDWARE AS SCHED.
104	A	SOLID CORE WOOD	3'-0" X 6'-8"	9TH	EXISTING	PT-1	-	A, C, F, H, I	
105	A	SOLID CORE WOOD	3'-0" X 6'-8"	9TH	EXISTING	PT-1	-	A, D, E, H, I, L	
106	A	SOLID CORE WOOD	3'-0" X 6'-8"	9TH	EXISTING	PT-1	-	A, C, F, H, I	
107	C	SOLID CORE WOOD	3'-0" X 6'-8"	9TH	EXISTING	PT-2	-	A, C, F, H, I, M	
108	A	SOLID CORE WOOD	3'-0" X 6'-8"	9TH	EXISTING	PT-1	-	A, B, G, I, J	
109	A	SOLID CORE WOOD	3'-0" X 6'-8"	9TH	EXISTING	PT-1	-	A, B, G, I, J	
110	A	SOLID CORE WOOD	3'-0" X 6'-8"	9TH	EXISTING	PT-1	-	A, B, G, I, J	
111	A	SOLID CORE WOOD	3'-0" X 6'-8"	9TH	EXISTING	PT-2	-	A, B, G, I, J	
112	A	SOLID CORE WOOD	3'-0" X 6'-8"	9TH	EXISTING	PT-2	-	A, B, G, I, J	
113	A	SOLID CORE WOOD	3'-0" X 6'-8"	9TH	EXISTING	PT-1	-	A, B, G, I, J	
114	A	SOLID CORE WOOD	3'-0" X 6'-8"	9TH	EXISTING	PT-1	-	A, B, G, I, J	
115	A	SOLID CORE WOOD	3'-0" X 6'-8"	9TH	EXISTING	PT-1	-	A, B, G, I, J	
116	A	SOLID CORE WOOD	3'-0" X 6'-8"	9TH	EXISTING	PT-1	-	A, B, G, I, J	
117	A	SOLID CORE WOOD	3'-0" X 6'-8"	9TH	EXISTING	PT-1	-	A, B, G, I, J	
117A	A	SOLID CORE WOOD	3'-0" X 6'-8"	9TH	EXISTING	PT-1	-	A, C, H, I	EX. TO REMAIN. G.C. TO VERIFY EX. HARDWARE MATCHES SET LISTED. IF NOT, PROVIDE APPROPRIATE HARDWARE AS SCHED.
118	A	SOLID CORE WOOD	3'-0" X 6'-8"	9TH	EXISTING	PT-2	-	A, B, G, I, J	
119	A	SOLID CORE WOOD	3'-0" X 6'-8"	9TH	EXISTING	PT-2	-	A, C, F, H, I	
120	A	SOLID CORE WOOD	3'-0" X 6'-8"	9TH	EXISTING	PT-2	-	A, I, K, O	
120A	A	SOLID CORE WOOD	3'-0" X 6'-8"	9TH	EXISTING	PT-1	-	A, C, H, I	EX. TO REMAIN. G.C. TO VERIFY EX. HARDWARE MATCHES SET LISTED. IF NOT, PROVIDE APPROPRIATE HARDWARE AS SCHED.
121	A	SOLID CORE WOOD	3'-0" X 6'-8"	9TH	EXISTING	PT-1	-	A, B, G, I, J	
121A	A	SOLID CORE WOOD	3'-0" X 6'-8"	9TH	EXISTING	PT-1	-	A, C, H, I	EX. TO REMAIN. G.C. TO VERIFY EX. HARDWARE MATCHES SET LISTED. IF NOT, PROVIDE APPROPRIATE HARDWARE AS SCHED.
122	A	SOLID CORE WOOD	3'-0" X 6'-8"	9TH	EXISTING	PT-1	-	A, B, G, I, J	
123	A	SOLID CORE WOOD	3'-0" X 6'-8"	9TH	EXISTING	PT-1	-	A, B, G, I, J	
124	A	SOLID CORE WOOD	3'-0" X 6'-8"	9TH	EXISTING	PT-1	-	A, B, G, I, J	
125	A	SOLID CORE WOOD	3'-0" X 6'-8"	9TH	EXISTING	PT-1	-	A, B, G, I, J	
126	A	SOLID CORE WOOD	3'-0" X 6'-8"	9TH	EXISTING	PT-1	-	A, B, G, I, J	
127	A	SOLID CORE WOOD	3'-0" X 6'-8"	9TH	EXISTING	PT-2	-	A, B, G, I, J	
128	A	SOLID CORE WOOD	3'-0" X 6'-8"	9TH	EXISTING	PT-1	-	A, B, G, I, J	
129	D	-	3'-2" X 6'-10"	-	EXISTING	PT-1	-	-	EX. FRAME TO REMAIN; FINISH TO MATCH. NO DOOR INSTALLED.
130	A	SOLID CORE WOOD	3'-0" X 6'-8"	9TH	EXISTING	PT-1	-	A, B, G, I, J	
131	A	SOLID CORE WOOD	3'-0" X 6'-8"	9TH	EXISTING	PT-1	-	A, B, G, I, J	
132	A	SOLID CORE WOOD	3'-0" X 6'-8"	9TH	EXISTING	PT-1	-	A, B, G, I, J	
133	A	SOLID CORE WOOD	3'-0" X 6'-8"	9TH	EXISTING	PT-1	-	A, D, I	
134	A	SOLID CORE WOOD	3'-0" X 6'-8"	9TH	EXISTING	PT-1	-	A, D, H, I, L	
134A	A	EXISTING	3'-0" X 4'-8" SUSPENDED	9TH	EXISTING	PT-1	-	A, D, E	EX. TO REMAIN. G.C. TO VERIFY EX. HARDWARE MATCHES SET LISTED. IF NOT, PROVIDE APPROPRIATE HARDWARE AS SCHED.
134B	A	EXISTING	3'-0" X 4'-8" SUSPENDED	9TH	EXISTING	PT-1	-	A, D, E	EX. TO REMAIN. G.C. TO VERIFY EX. HARDWARE MATCHES SET LISTED. IF NOT, PROVIDE APPROPRIATE HARDWARE AS SCHED.
134C	A	EXISTING	3'-0" X 4'-8" SUSPENDED	9TH	EXISTING	PT-1	-	A, D, E	EX. TO REMAIN. G.C. TO VERIFY EX. HARDWARE MATCHES SET LISTED. IF NOT, PROVIDE APPROPRIATE HARDWARE AS SCHED.
135	A	SOLID CORE WOOD	3'-0" X 6'-8"	9TH	EXISTING	PT-1	-	A, C, F, H, I	
135A	EX. A	EXISTING	3'-0" X 6'-8"	EX TO REMAIN	ALUMINUM	EX TO REMAIN	-	A, C, F, H, I	EX. TO REMAIN. G.C. TO VERIFY EX. HARDWARE MATCHES SET LISTED. IF NOT, PROVIDE APPROPRIATE HARDWARE AS SCHED.
135B	EX. A	EXISTING	3'-0" X 6'-8"	EX TO REMAIN	ALUMINUM	EX TO REMAIN	-	A, C, F, H, I	EX. TO REMAIN. G.C. TO VERIFY EX. HARDWARE MATCHES SET LISTED. IF NOT, PROVIDE APPROPRIATE HARDWARE AS SCHED.

HARDWARE

- 1/2 FAIR BUTT HINGES, ANSI 156.1, A8111, HAGER BBI168 (ANSI A2111 / BRUSH NICKEL CHROME).
- LEVER LOCKSET, SCHLAGE ALSP0 (ENTRANCE / OFFICE LOCK) W/ DEADLATCH AND CONVENTIONAL 6-PIN CYLINDER. JUPITER LEVER, COLOR 626 (SATIN CHROMIUM PLATED). KEYED SEPARATELY AND MASTER KEYED.
- LEVER LOCKSET, SCHLAGE ALSP0 (STOREROOM LOCK) W/ DEADLATCH AND CONVENTIONAL 6-PIN CYLINDER. JUPITER LEVER, COLOR 626 (SATIN CHROMIUM PLATED). KEYED SEPARATELY AND MASTER KEYED.
- LEVER LOCKSET, SCHLAGE ALIOS (PASSAGE LATCH) W/ SPRINGSLATCH. JUPITER LEVER, COLOR 626 (SATIN CHROMIUM PLATED).
- DEADBOLT, SCHLAGE BEYOND-SIDED DEADBOLT W/ COMPANY INDICATOR, COLOR 626 (SATIN CHROMIUM PLATED).
- DOOR FRAME TO ACCEPT ELECTRIC STRIKE FOR ACCESS CONTROL SYSTEM (BY TENANT); PROVIDE 5/16" ELECTRICAL CONDUIT OF FRAME FROM 42" AFF STUBBED INTO CEILING SPACE, REMOVE DUST EX. COORDINATE W/ ANY REQUIRED EGRESS HARDWARE @ EXTERIOR DOORS ONLY.
- BRICK POINT COAT MARK ON INSIDE OF EACH DOOR. COORDINATE LOCATION W/ CBRE PROJECT MANAGER IN FIELD.
- DOOR CLOSER, HSI 156.4, GRADE I, LCN 1450 SERIES (PARALLEL ARM), CLR ANODIZED.
- MALL DOOR STOP, HSI A156.16/EMMA L12101, 6LYNN-JOHNSON 50C
- REECE 450A AUTOMATIC DOOR BOTTOM SEAL
- REECE 500C AUTOMATIC DOOR BOTTOM SEAL
- ADA RESTROOM SIGNAGE.
- VENT IN DOOR, 20" x 8". REFER MECH DWS6 FOR CONT.

HARDWARE NOTES:

- HARDWARE SCHEDULES BY REFERENCE TO A MANUFACTURER IS FOR THE PURPOSE OF ESTABLISHING MINIMUM REQUIREMENTS.
- ALL HANDLES, PULLS, LATCHES, LOCKS AND OTHER OPERATING DEVICES ON ACCESSIBLE DOORS SHALL HAVE A SHAPE THAT IS EASY TO GRASP WITH ONE HAND AND DOES NOT REQUIRE TIGHT GRASPING, FINCHING OR TWISTING TO OPERATE.
- MAXIMUM EFFORT TO OPERATE DOORS SHALL NOT EXCEED FIVE (5) POUNDS, PUSH & PULL.
- HARDWARE FOR PAIRS OF DOORS IS FOR EACH LEAF, UNLESS NOTED.
- G.C. TO COORDINATE W/ OWNER FOR PROPER KEYING OF CORES PRIOR TO INSTALLATION
- GENERAL NOTES:
G.C. IS TO INSPECT ALL EX. HARDWARE AND SYSTEMS FOR DEFECTS, DAMAGE AND OPERABILITY. IF ANY ITEMS OR ELEMENTS ARE FOUND TO BE INSUFFICIENT G.C. SHALL REPAIR OR REPLACE AS NECESSARY TO ENSURE COMPLETE OPERABILITY AND SYSTEM.
- G.C. TO FIELD VERIFY ALL DIMENSIONS PRIOR TO ORDERING OF HARDWARE AND DOOR SYSTEMS.
- ALL DOOR MATERIALS, FINISHES AND STYLES ETC. ARE TO BE COORDINATED W/ TENANT PRIOR TO CONSTRUCTION.

MATERIAL SCHEDULE

MATERIAL	SYMBOL	DESCRIPTION	NUMBER	COLOR	MANUFACTURER
PAINT	P-1	EGGSHELL	596001	GRAYISH	SHERWIN WILLIAMS
	P-2	EGGSHELL	590018	TEAL STENCIL	SHERWIN WILLIAMS
	P-3	EGGSHELL W/ EPOXY	590018	TEAL STENCIL	SHERWIN WILLIAMS
	P-4	FLAT		WHITE	SHERWIN WILLIAMS
CARPET TILE	CPT-1	PRIMARY STITCH 1462102500	102417	FRENCH KNOT	INTERFACE
	CPT-2	PLATFORM 1467202500	4325	CHESTNUT	INTERFACE
VINYL COMPOSITION TILE	VGT-1	STANDARD EXCELON IMPERIAL TEXTURE	54242	CAROB	ARMSTRONG
STATIC DISSIPATIVE TILE	SDT-1	SDT	51950	MARBLE BEIGE	ARMSTRONG
WALL BASE	RB-1	MANNING EDGE	167	FUDGE	MANNINGTON
	RB-2	CTA-XX-D 5/16" TO 1/8"	167	FUDGE	JOHNSONITE
PLASTIC LAMINATE	PL-1	STANDARD	4820-60	CARBON EV	MILSONART
	PL-2	STANDARD / MATTE	D354-60	DESIGNER WHITE	MILSONART
WOOD STAIN	STN-1	POLYURETHANE CLEAR SATIN	222	SEDONA	MINWAX

FINISH NOTES:

- ALL INSTALLATIONS OF MATERIALS ARE TO BE PER MANUFACTURER'S RECOMMENDATIONS AND SPECIFICATIONS. CONTACT ARCHITECT, LIFEWORKS PROJECT MANAGER, AND MANUF. BEFORE DEVIATING FROM SPECIFICATIONS AND INSTRUCTION.
- ALL PAINT & STAIN IS TO BE SHOP APPLIED, WHERE APPLICABLE.
- CARPET TILE PATTERNS ARE TO BE LAID AS SHOWN BELOW:
QUARTER TURN BRICK:

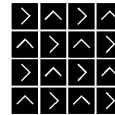

ROOM FINISH SCHEDULE

ROOM #	ROOM NAME	FLOOR	WALLS	BASE	CEILING	COMMENTS
100	WAITING AREA	CPT-1	PT-1	EX.	GYP BD, PT-4	----
101	RECEPTION	CPT-2	PT-1	RB-1	GYP BD, PT-4	----
102	MEN'S RESTROOM	EX.	PT-1	EX.	GYP BD, PT-4	----
103	MECHANICAL ROOM	CONG-1	PT-1	EX.	EXPOSED	----
104	TESTING ROOM	VGT-1	PT-1	EX.	GYP BD, PT-4	----
105	RESTROOM	VGT-1	PT-1, PT-3	EX.	GYP BD, PT-4	----
106	MAIL ROOM	CPT-2	PT-1	EX.	GYP BD, PT-4	----
107	I.T. CLOSET	SDT-2	PT-1	RB-1	EXPOSED	----
108	OFFICE	CPT-2	PT-1	EX.	GYP BD, PT-4	----
109	CLINICIAN	CPT-2	PT-1	EX.	GYP BD, PT-4	----
110	CLINICIAN	CPT-2	PT-1	EX.	GYP BD, PT-4	----
111	CLINICIAN	CPT-2	PT-1	EX.	GYP BD, PT-4	----
112	CLINICIAN	CPT-2	PT-1	EX.	GYP BD, PT-4	----
113	CLINICIAN	CPT-2	PT-1	EX.	GYP BD, PT-4	----
114	CLINICIAN	CPT-2	PT-1	EX.	GYP BD, PT-4	----
115	CLINICIAN	CPT-2	PT-1	EX.	GYP BD, PT-4	----
116	CLINICIAN	CPT-2	PT-1	EX.	GYP BD, PT-4	----
117	GROUP THERAPY	CPT-2	PT-1	EX.	GYP BD, PT-4	----
118	CLINICIAN	CPT-2	PT-1	EX.	GYP BD, PT-4	----
119	MECHANICAL ROOM	CONG-1	PT-1	EX.	EXPOSED	----
120	OPEN AREA	CPT-2	PT-1	EX.	GYP BD, PT-4	----
121	CLINICIAN	CPT-2	PT-1	EX.	GYP BD, PT-4	----
122	CLINICIAN	CPT-2	PT-1	EX.	GYP BD, PT-4	----
123	CLINICIAN	CPT-2	PT-1	EX.	GYP BD, PT-4	----
124	CLINICIAN	CPT-2	PT-1	EX.	GYP BD, PT-4	----
125	CLINICIAN	CPT-2	PT-1	EX.	GYP BD, PT-4	----
126	CLINICIAN	CPT-2	PT-1	EX.	GYP BD, PT-4	----
127	GROUP THERAPY	CPT-2	PT-1	EX.	GYP BD, PT-4	----
128	CLINICIAN	CPT-2	PT-1	EX.	GYP BD, PT-4	----
129	CLINICIAN	CPT-2	PT-1	EX.	GYP BD, PT-4	----
130	CLINICIAN	CPT-2	PT-1	EX.	GYP BD, PT-4	----
131	CLINICIAN	CPT-2	PT-1	EX.	GYP BD, PT-4	----
132	CLINICIAN	CPT-2	PT-1	EX.	GYP BD, PT-4	----
133	BREAK ROOM	CPT-2	PT-1	EX.	GYP BD, PT-4	----
134	WOMEN'S RESTROOM	EX.	PT-1	EX.	GYP BD, PT-4	----
135	CORRIDOR	CPT-2	PT-1, PT-2	EX.	GYP BD, PT-4	----

ROOM FINISH NOTES:

- REFER TO INTERIOR ELEVATIONS & SECTIONS FOR LOCATION OF ALL INTERIOR FINISHES. PROVIDE AS SPECIFIED AND PER MANUF. RECOMMENDATIONS & SPECIFICATIONS.
- VERIFY FINISH MATERIAL W/ TENANT PROJECT MANAGER PRIOR TO ORDER AND INSTALLATION. PROVIDE PHYSICAL SAMPLES & CUTSHEETS FOR ALL FINISH MATERIAL & HARDWARE.
- WHERE EX. FINISHES ARE TO REMAIN, G.C. TO VERIFY MATERIALS ARE CLEAN AND IN GOOD CONDITION, AND TO CLEAN, REPAIR, OR REPLACE AS NECESSARY.
- WHERE EX. WALL BASE IS IN GOOD CONDITION, RETAIN AND REUSE. PAINT TO MATCH ADJACENT WALL. REPLACE WITH RB-1 WHERE NECESSARY.
- REFER TO MILLWORK / CASEWORK DETAILS FOR CABINETS' BASE FINISHES.

DOOR & FRAME TYPES

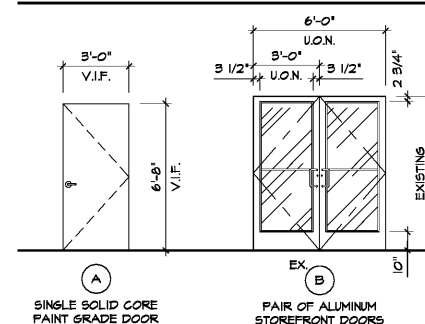

SINGLE SOLID CORE PAINT GRADE DOOR

PAIR OF ALUMINUM STOREFRONT DOORS

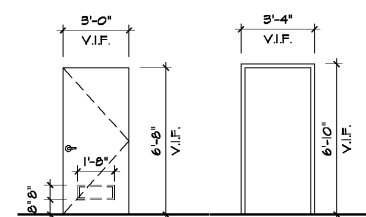

SINGLE SOLID CORE DOOR W/ VENT

2" FRAME, EXISTING

FRED MARGULIES ARCHITECT
 25001 Emory Road, Suite 400
 Cleveland, Ohio 44128
 216.223.3200 fredmargulies.com

Design and construction documents as instruments of service are given in confidence and remain the property of Fred S. Margulies, Architect. The use of this design and these construction documents for purposes other than the specific project named herein is strictly prohibited without expressed written consent of Fred S. Margulies, Architect.

LifeStance HEALTH
 TENANT IMPROVEMENT
 648 CHARITY COURT
 FRANKFORT, KY 40601

Project No: 16632
 Drawn By: BCR
 Date: 08-29-18
 Issue: Owner Review
 09-05-18: Bid & Permit

A3.2

SCHEDULES

Job: 16632-01-01A - 648 Charity Court - Tenant Improvement - 2018-08-29
 Drawn: BCR
 Date: 08-29-18