

1 ROUND DUCT SUPPORT

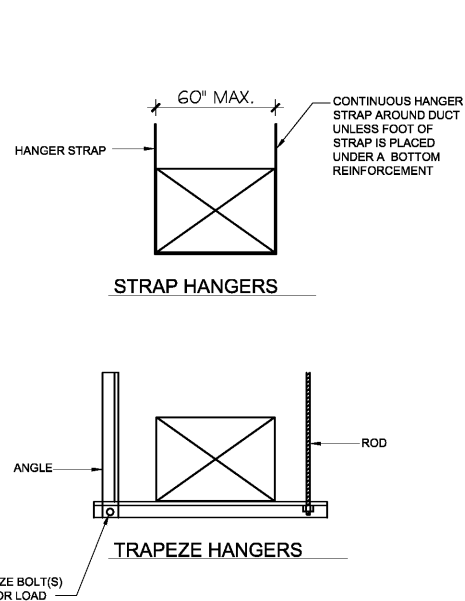

2 RECTANGULAR DUCT SUPPORT

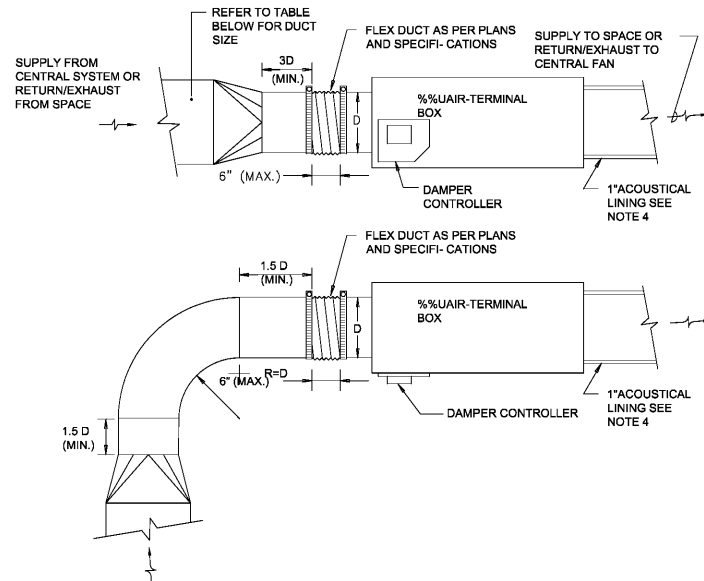

3 AIR TERMINAL BOX CONNECTION

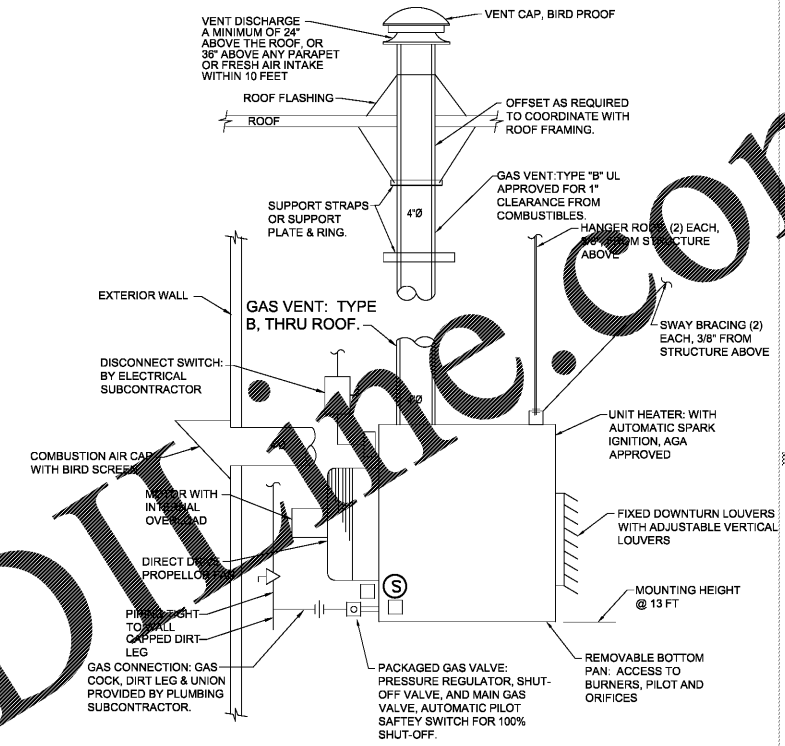

4 GAS FIRED UNIT HEATER DETAIL

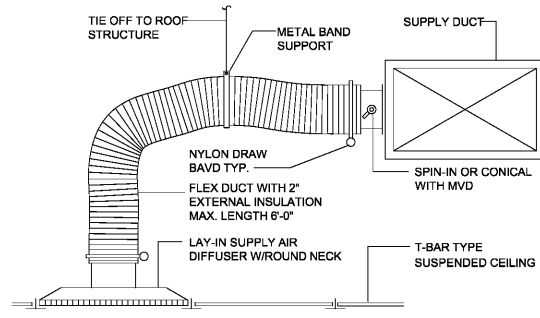

5 SUPPLY AIR DIFFUSER

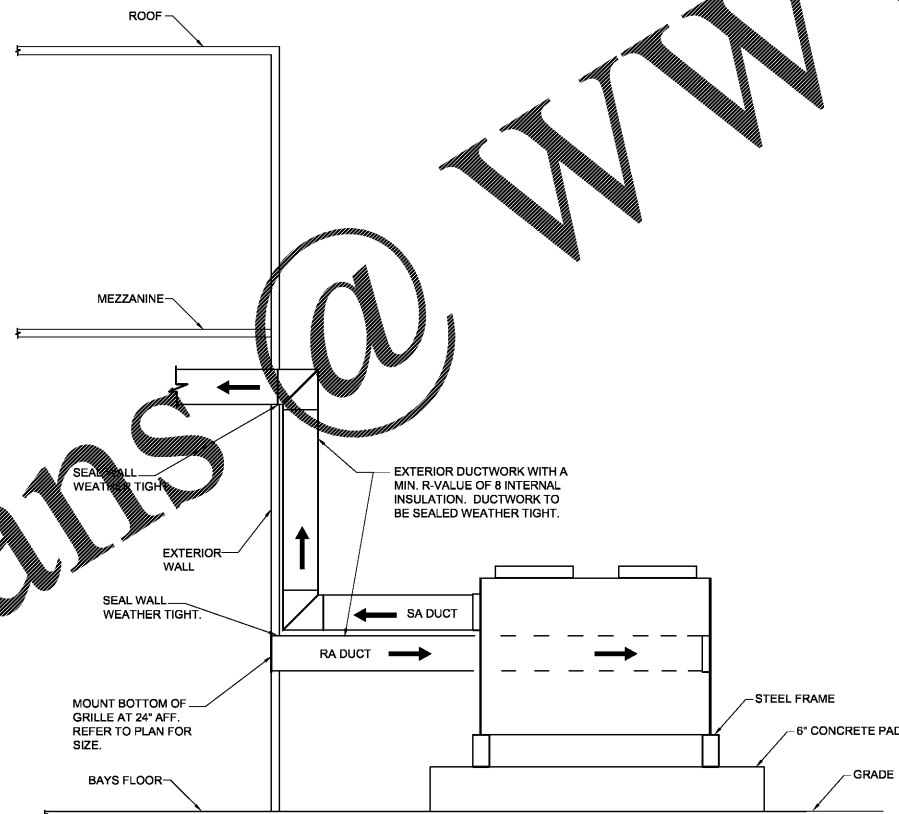

6 DOAS UNIT WITH HORIZONTAL DISCHARGE DETAIL

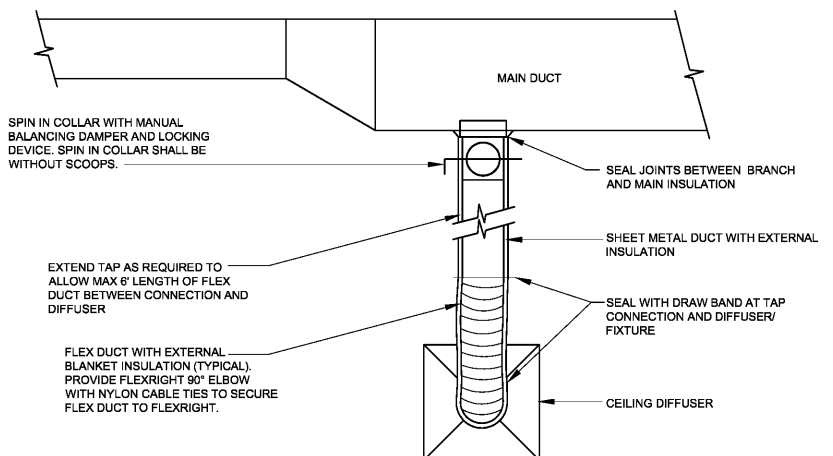

7 DUCT MAIN AND DIFFUSER CONNECTION

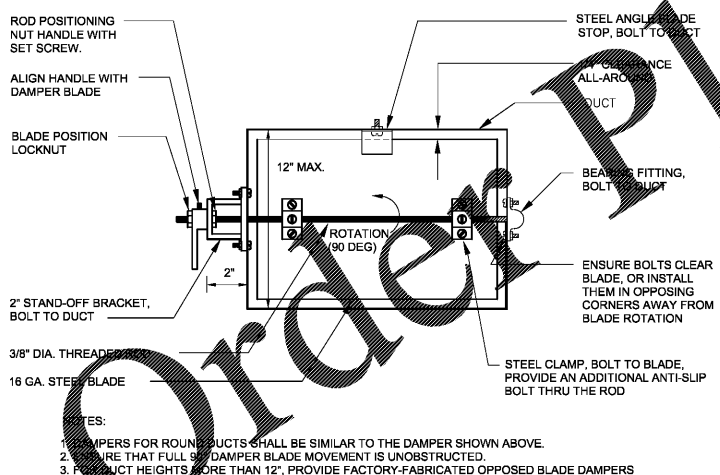

8 MANUAL DAMPER (ADJ SINGLE-BLADE TYPE)

**CLAYTON COUNTY
NEW FIRE STATION #9**
 4178 OLD DIXIE
HIGHWAY
ATLANTA, GEORGIA
30364
 CLAYTON COUNTY
FIRE DEPARTMENT

SKING
Associates, Inc.
 ENGINEERS • PLANNERS • MANAGERS
 270 Peachtree Street, N.W.
 Suite 1600
 Atlanta, GA 30303
 (M) 404.524.5800
 (F) 404.584.1799
 www.sking.com

Boye Architecture
 ARCHITECTURE

INTERIOR DESIGN
 LAND PLANNING
 180 CLAIRBORNE AVE., STE 120
 DECATUR, GEORGIA
 TEL: 478.355.8884

www.boyearchitecture.com

RELEASED FOR
 CONSTRUCTION
 100% CD

**MECHANICAL -
DETAILS**

M501