

- NOTES:**
1. SECURE CURB CAP TO WOOD NAILING STRIP WITH 3/8" CADMIUM PLATED LAG BOLTS NOT OVER 12" ON CENTER.
 2. SECURE ROOF CURB, DUCTWORK AND DAMPER TO ROOF WITH RUST RESISTANT BOLTS.
 3. SIZE OF DUCT THROUGH ROOF SHALL NOT BE LARGER THAN CURB SUPPLIED WITH ROOF VENTILATOR.
 4. RUN ELECTRIC LINES THROUGH CLEARANCE HOLE PROVIDED IN GRAVITY DAMPER THEN THROUGH VENTILATOR ELECTRICAL CONDUIT GUIDE.

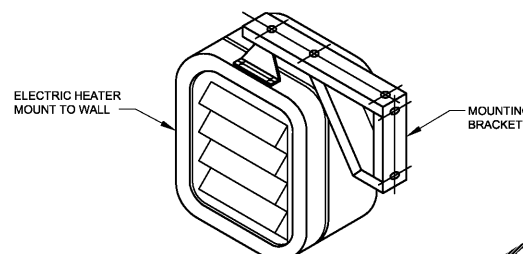

- NOTES:**
1. O/A, RELIEF AIR, AND INTERNAL MIXING DAMPER TO BE PROVIDED BY UNIT MANUFACTURER. DAMPER SHALL BE PROVIDED WITH ELECTRIC ACTUATOR.
 2. FAN MOTOR SHALL BE INTERNALLY ISOLATED.
 3. SIZE OF S/A AND R/A DUCTWORK ON HVAC PLAN. TRANSITION DUCTWORK TO OPENING SIZE IN RTU.

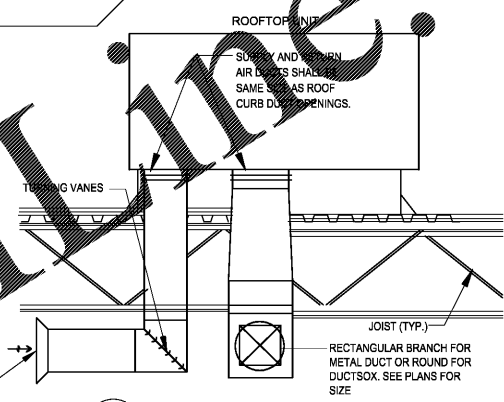
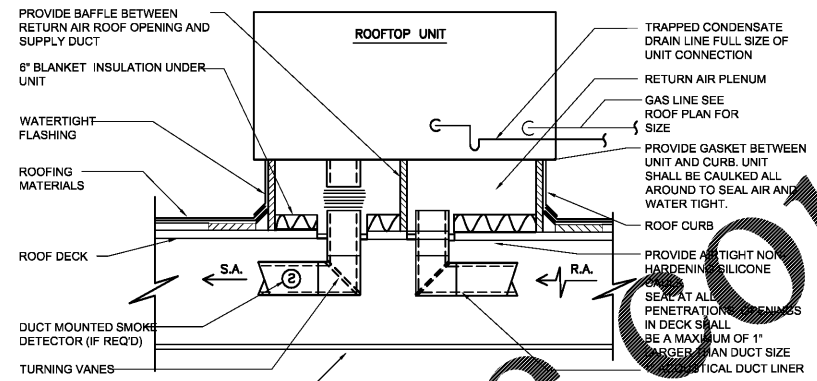

1 BRANCH CONNECTION (TYP)
M-500 SCALE: NONE

2 ROOF MOUNTED EXHAUST FAN
M-500 SCALE: NONE

3 ELECTRIC UNIT HEATER DETAIL
M-500 SCALE: NONE

4 ROOF-TOP UNIT
M-500 SCALE: NONE

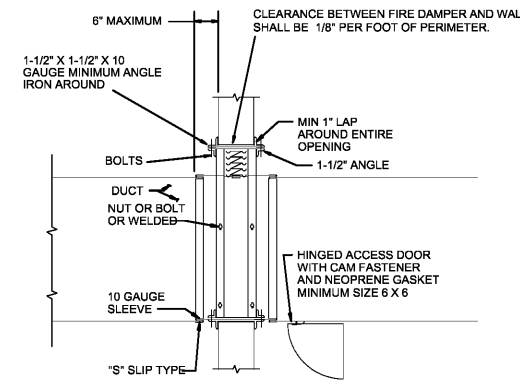

5 FIRE DAMPER
M-500 NO SCALE

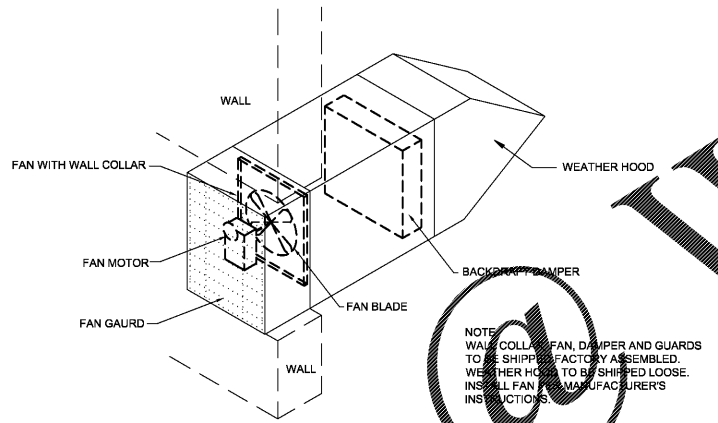

6 WALL MOUNTED EXHAUST PROPELER FAN
M-500 SCALE: NONE

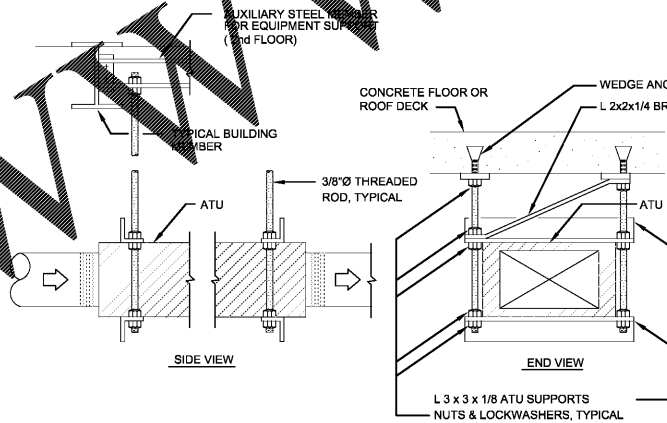

7 FAN POWERED TERMINAL MOUNTING DETAIL
M-500 SCALE: NONE

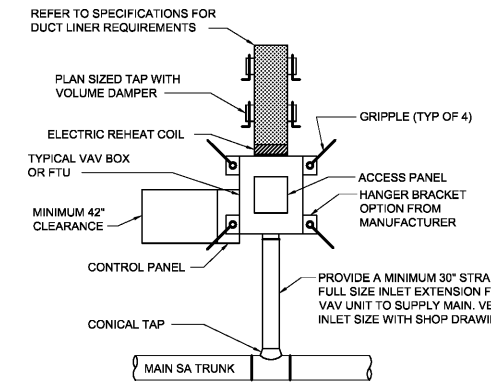

8 FAN POWERED TERMINAL UNIT DETAIL
M-500 SCALE: NONE

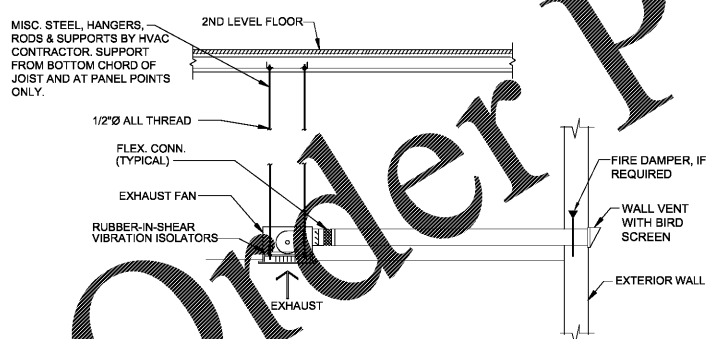

9 CEILING EXHAUST FAN DETAIL
M-500 SCALE: NONE

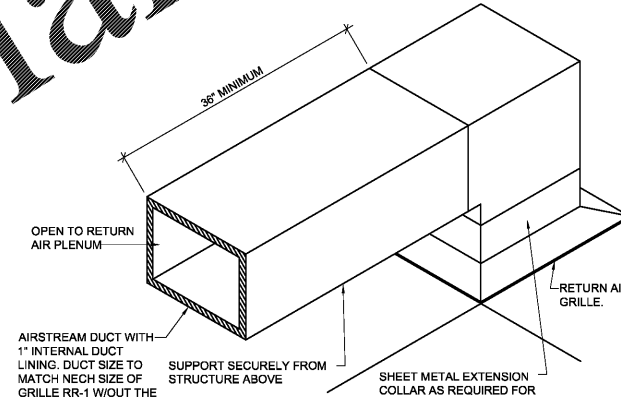

10 RETURN AIR TRANSFER DETAIL
M-500 SCALE: NONE

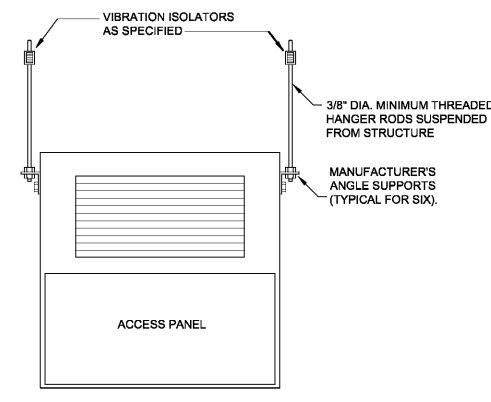

11 EXHAUST AIR CLEANER INSTALLATION DETAIL
M-500 SCALE: NONE

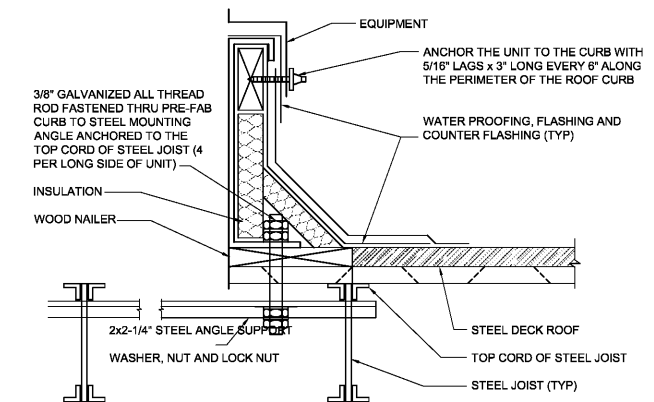

12 ROOF CURB DETAIL
M-500 SCALE: NONE

- NOTES:**
1. ANCHOR OR SECURE RTU CURB TO ROOF STRUCTURE WITH ALL THREAD ROD THRU BOLTS AS SHOWN.
 2. ANCHOR OR SECURE UNIT TO CURB WITH LAG BOLTS THRU THE CURB NAILER. PROVIDE A MINIMUM OF THREE BOLTS PER SIDE OF UNIT. COORDINATE WITH STRUCTURAL AND PRODUCT REQUIREMENTS.
 3. COORDINATE CURB HEIGHT WITH THERMAL INSULATION AND ROOFING MATERIAL THICKNESS.
 4. COORDINATE PROPER WATERPROOFING OF CURB INTERFACE WITH ROOFING MATERIALS PER MANUFACTURERS RECOMMENDATIONS.

CLAYTON COUNTY
NEW FIRE STATION #9
4178 OLD DIXIE
HIGHWAY
ATLANTA, GEORGIA
30364
CLAYTON COUNTY
FIRE DEPARTMENT

SKING
Associates, Inc.
ENGINEERS • PLANNERS • MANAGERS
270 Peachtree Street, N.W.
Suite 1600
Atlanta, GA 30303
(M) 404.524.5800
(F) 404.584.1799
www.sking.com

Boye Architecture
ARCHITECTURE
INTERIOR DESIGN
LAND PLANNING
180 CLAIRBORNE AVE., STE 120
DECATUR, GEORGIA
TEL: 470.353.8884

WWW.BOYEARCHITECTURE.COM

GEORGIA REGISTERED PROFESSIONAL ENGINEER
M. BOYE
07/26/2018

RELEASED FOR CONSTRUCTION

DATE: 07/26/2018
PROJECT NO: 2017017
DRAWN BY: JS
CHECKED BY: AG

MECHANICAL - DETAILS

M500