

**3 LIGHTING CONTROL DIAGRAM**  
 SCALE: NONE

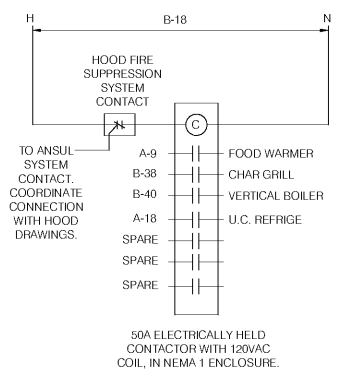

**4 KITCHEN CONTACTOR DETAIL**  
 SCALE: NONE

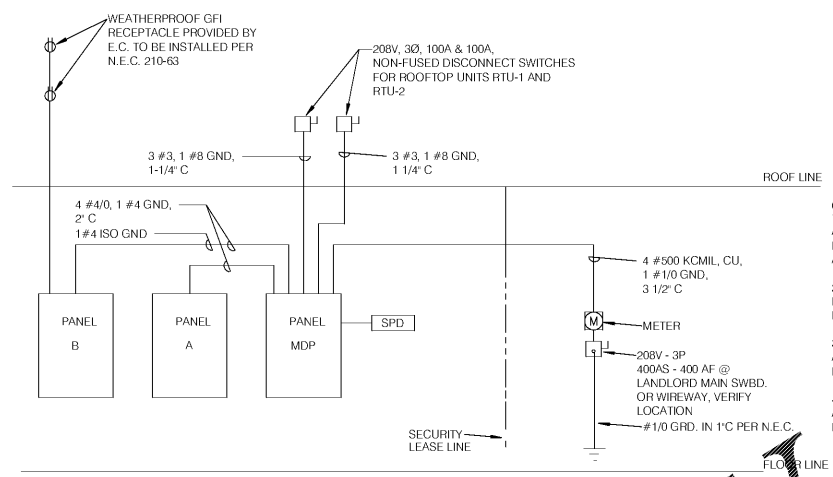

**5 ELECTRICAL ONE-LINE DIAGRAM**  
 SCALE: NONE

GENERAL NOTES:  
 1. ALL WIRE SHALL BE THW, THWN, THHW, OR NEC APPROVED EQUAL OR BETTER. ALL WIRING SHALL BE IN CONDUIT. WIRE AMPACITY BASED ON NEC 110-14c AND TABLE 310-16.  
 2. E.C. SHALL FURNISH ALL NEW ELECTRICAL EQUIPMENT (PANELS, TRANSFORMERS, CONDUIT, ETC.) AS REQUIRED, UNLESS NOTED OTHERWISE.  
 3. CONTRACTOR SHALL COORDINATE WITH POWER CO. AND VERIFY FAULT CURRENT, PROTECT AND LABEL RATED EQUIPMENT.  
 4. CONTRACTOR SHALL COORDINATE WITH POWER CO. AND DETECTIVE ARC FLASH, AND PROVIDE LABELING FOR NEC.

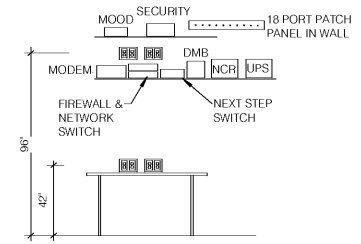
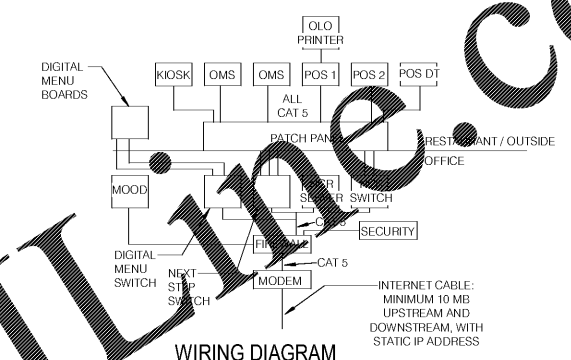

**OFFICE EQUIPMENT ELEVATION**

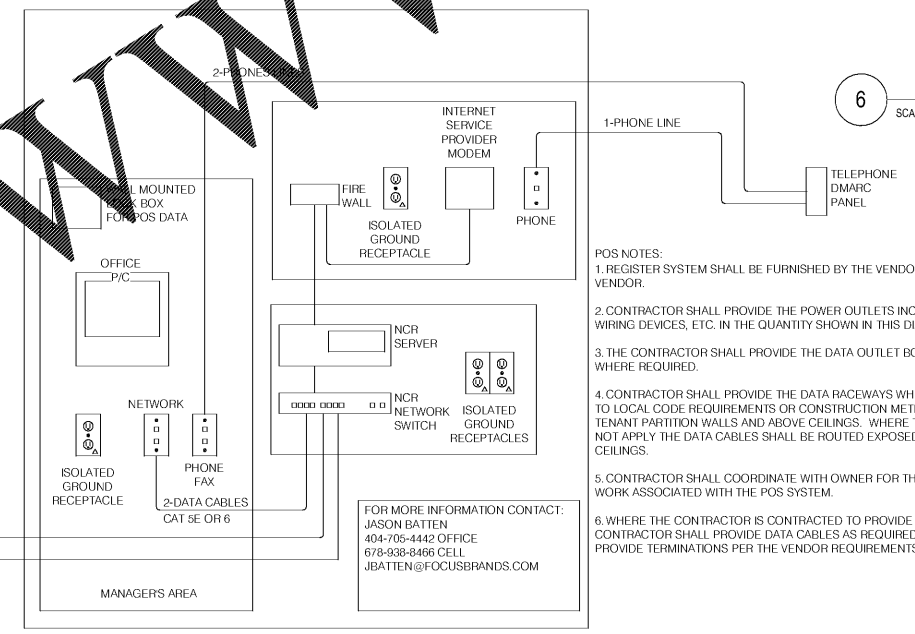

**6 OFFICE EQUIPMENT ELEVATION AND WIRING DETAIL**  
 SCALE: NONE

POS NOTES:  
 1. REGISTER SYSTEM SHALL BE FURNISHED BY THE VENDOR AND INSTALLED BY THE VENDOR.  
 2. CONTRACTOR SHALL PROVIDE THE POWER OUTLETS INCLUDING WIRE, CONDUIT, WIRING DEVICES, ETC. IN THE QUANTITY SHOWN IN THIS DIAGRAM AND ON THE PLANS.  
 3. THE CONTRACTOR SHALL PROVIDE THE DATA OUTLET BOXES AND CONDUITS WHERE REQUIRED.  
 4. CONTRACTOR SHALL PROVIDE THE DATA RACEWAYS WHERE AND IF REQUIRED, DUE TO LOCAL CODE REQUIREMENTS OR CONSTRUCTION METHODS, BELOW GRADE, IN TENANT PARTITION WALLS AND ABOVE CEILINGS. WHERE THE ABOVE CONDITIONS DO NOT APPLY THE DATA CABLES SHALL BE ROUTED EXPOSED IN THE WALLS AND ABOVE CEILINGS.  
 5. CONTRACTOR SHALL COORDINATE WITH OWNER FOR THE REMAINING SCOPE OF WORK ASSOCIATED WITH THE POS SYSTEM.  
 6. WHERE THE CONTRACTOR IS CONTRACTED TO PROVIDE THE DATA CABLES, THE CONTRACTOR SHALL PROVIDE DATA CABLES AS REQUIRED BY THE POS VENDOR AND PROVIDE TERMINATIONS PER THE VENDOR REQUIREMENTS.

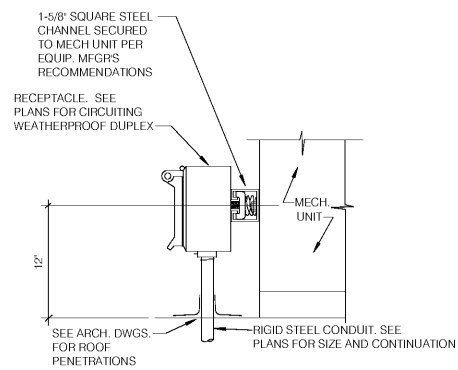

**1 RTU RECEPTACLE MOUNTING DETAIL**  
 SCALE: NONE

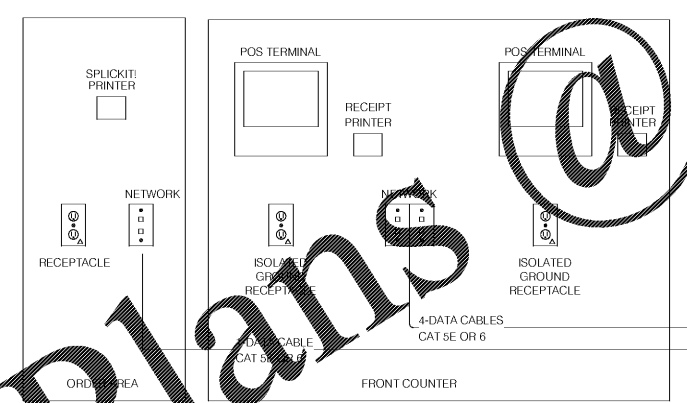

**2 DATA / TELEPHONE WIRING DIAGRAM**  
 SCALE: NONE

REV. NO.	DATE	ISSUED FOR PERMIT	DESCRIPTION
	07/27/18		

**DRAFT**

**MOE'S SOUTHWEST GRILL**  
 3732 US HWY 280  
 PHOENIX CITY, AL 36867

**ELECTRICAL DETAILS**

DATE:	
BRAND REVIEW	07/27/2018
PERMIT	07/27/2018
BID	-/-/-
CONSTRUCTION	-/-/-
RECORDED	-/-/-

PROJECT MANAGER	DESIGNER
JB	JW

JOB NO.  
**2018375.13**

**E-510**

**Order Plans**