

WWW.LDILine.com

REV. NO.	DATE	ISSUE FOR PERMIT	DESCRIPTION
	07/27/18		

DRAFT

MOE'S SOUTHWEST GRILL
 3732 US HWY 280
 PHOENIX CITY, AL 36867

FOUNDATION SECTIONS
 AND DETAILS

DATE:	
BRAND REVIEW	07/27/2018
PERMIT	07/27/2018
BID	--/--/----
CONSTRUCTION	--/--/----
RECORDED	--/--/----
PROJECT MANAGER	DESIGNER
JB	SC

JOB NO.
 2018375.13

S-510

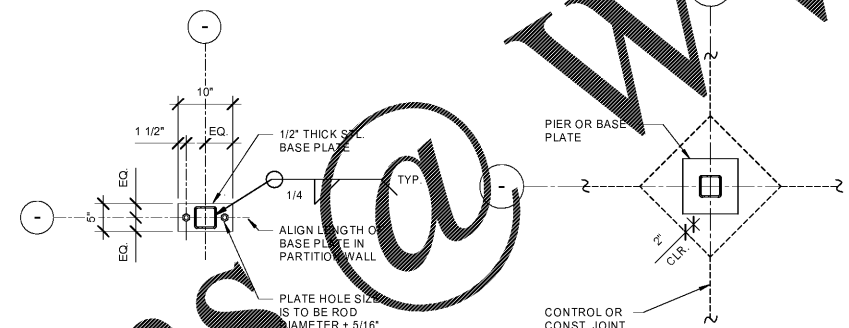
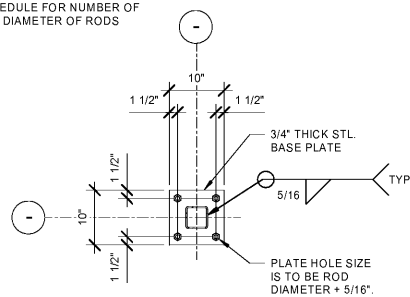
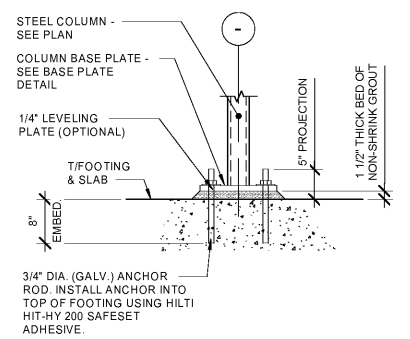
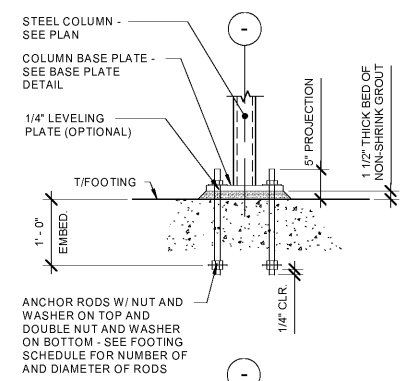

NOTES:
 1. COLUMN TO BE CENTERED ON BASE PLATE - TYP. U.N.O.

NOTES:
 1. COLUMN TO BE CENTERED ON BASE PLATE - TYP. U.N.O.

6 BASE PLATE DETAIL - "A"
 3/4" = 1'-0"

7 BASE PLATE DETAILS - "B"
 3/4" = 1'-0"

8 ISOLATION JOINT DETAIL
 3/4" = 1'-0"

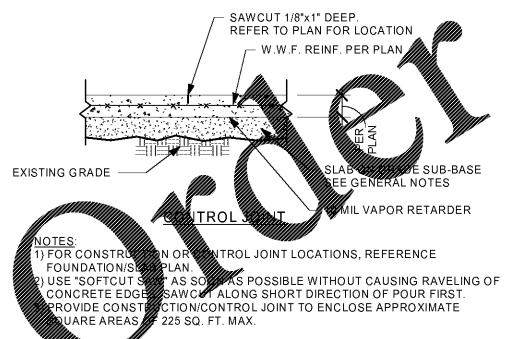

NOTES:
 1) FOR CONSTRUCTION OR CONTROL JOINT LOCATIONS, REFERENCE FOUNDATIONS PLAN.
 2) USE 'SOFTCUT' AS MUCH AS POSSIBLE WITHOUT CAUSING RAVELING OF CONCRETE EDGES. SAWCUT ALONG SHORT DIRECTION OF POUR FIRST.
 3) PROVIDE CONSTRUCTION CONTROL JOINT TO ENCLOSE APPROXIMATE SQUARE AREAS: 225 SQ. FT. MAX.

1 TYP. SLAB ON GRADE JOINT DETAILS
 3/4" = 1'-0"

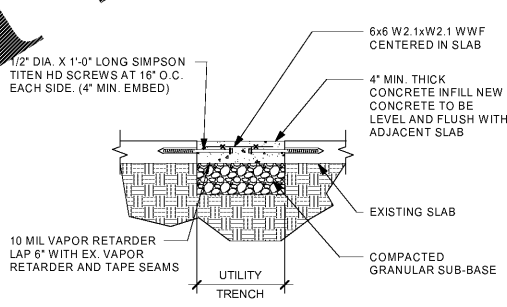

2 UTILITY TRENCH DETAIL
 3/4" = 1'-0"

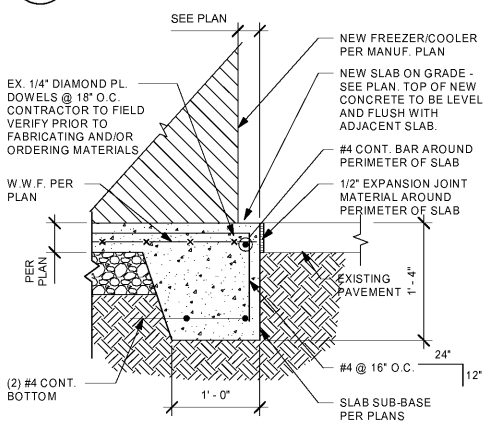

3 TYP. TURN DOWN FTG. DETAIL
 1" = 1'-0"

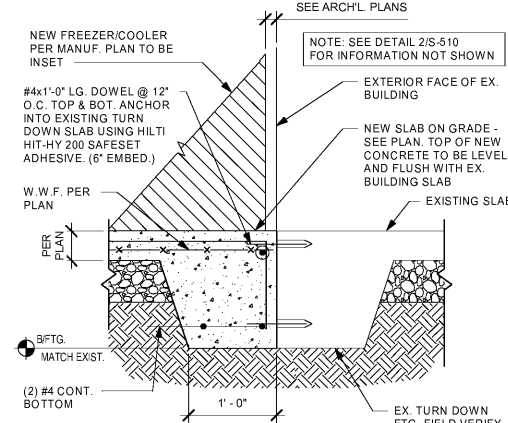

4 TURN DOWN FTG. DETAIL @ BUILDING
 1" = 1'-0"

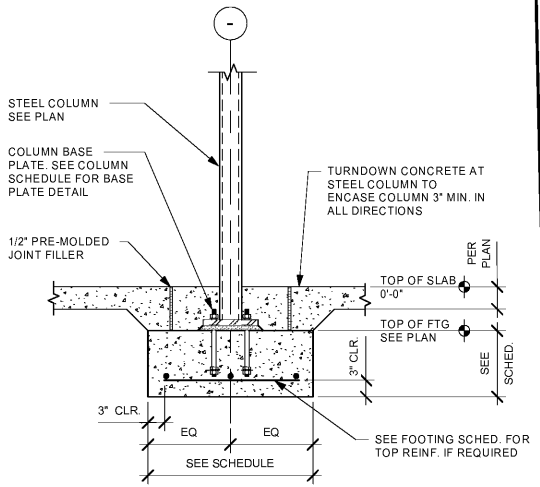

5 COLUMN FOOTING DETAIL
 3/4" = 1'-0"