

DRAWING INFORMATION		
DATE	DESCRIPTION	BY
05-13-18	FOR CONSTRUCTION	KM

**NCA**  
CONSULTANTS / GROUP  
4585 140TH AVE. NORTH, SUITE #1001  
CLEARWATER, FLORIDA  
PHONE: (877) 530-0078  
CALL NCA MARKETING FOR PRICING  
NCA JOB# 18-576

CHECKED BY: JMH, ENH  
DATE: 05/22/18  
NO. 05/22/18  
RELEASED FOR CONSTRUCTION & BID



PREMIER KINGS, INC.  
5529 CARMICHAEL ROAD  
MONTGOMERY, ALABAMA 36117  
PHONE: (205) 833-1111  
WWW.PREMIERKINGS.COM

2126 Morris Avenue  
Birmingham, AL 35203  
Phone: (205) 322-1751  
Fax: (205) 322-1778  
email: info@jamesmuckstein.com  
www.jmuckstein.com

James M. Muckstein  
architect AIA

architecture • planning • interior design

SHANE R. HAMILTON, P.E.  
1717 N. HOWARD AVENUE, TAMPA, FL 33607  
GEORGIA LICENSE # 0411311

Shane R. Hamilton  
No. PE 125118  
SHANE R. HAMILTON

PROJECT # 18026.07  
RUC-60 20/20 IMAGE APRIL 2015 DESIGN RELEASE  
BURGER KING RESTAURANT  
1717 N. HOWARD AVENUE  
Tampa, FL 33607 (813) 251-6848

HOOD DETAILS  
U.S. Hwy 278  
Corning, GA

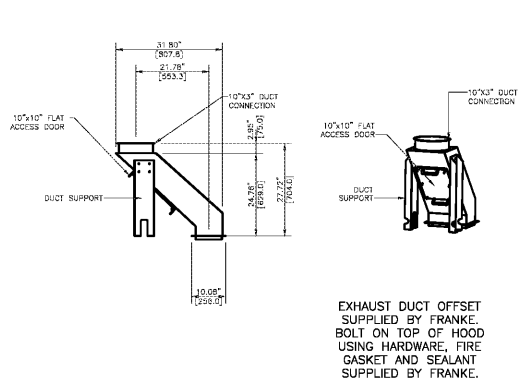

1 EXHAUST DUCT OFFSET DETAIL  
SCALE: NO SCALE

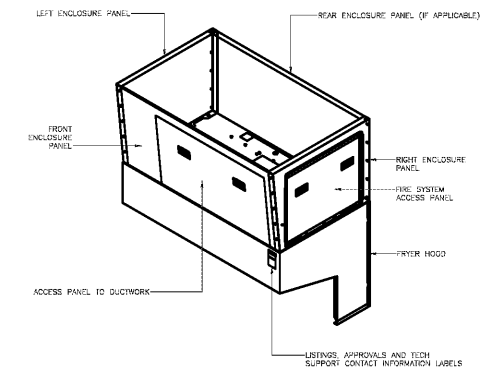

2 HOOD ENCLOSURE DETAIL  
SCALE: NO SCALE

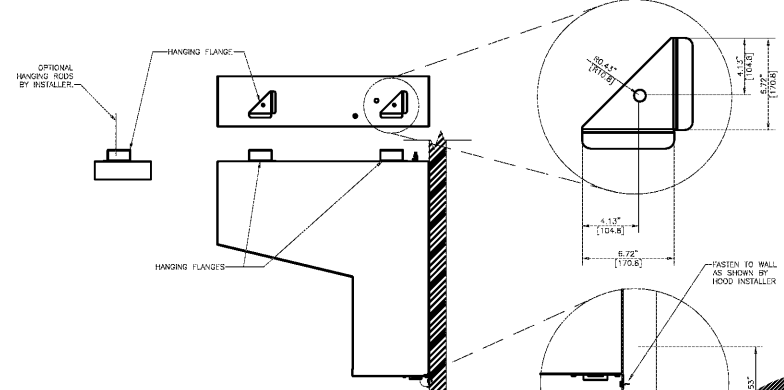

3 FRYER HOOD HANGING DETAIL  
SCALE: NO SCALE

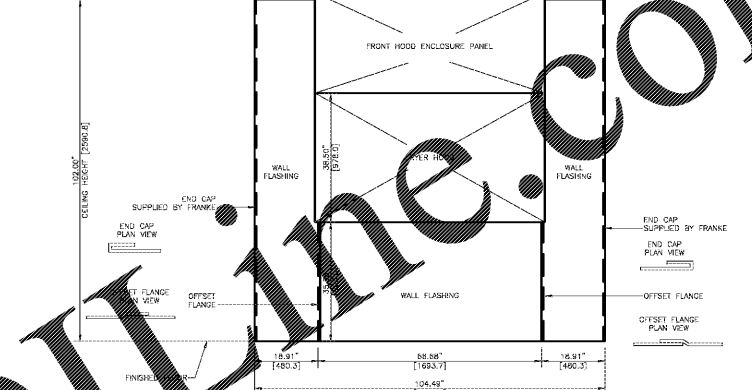

4 FRYER HOOD WALL FLASHING DETAIL  
SCALE: NO SCALE

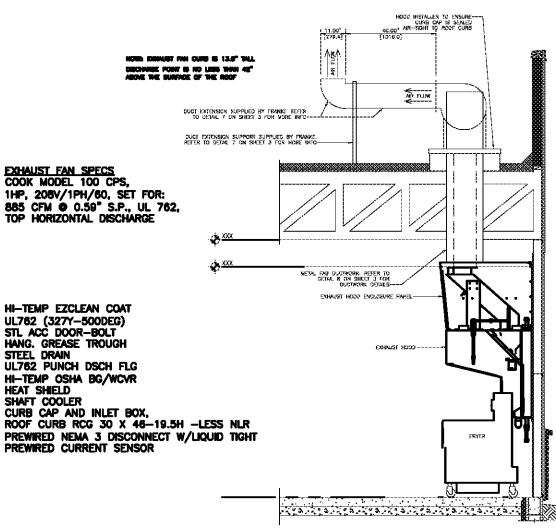

5 FRYER HOOD EXHAUST FAN DETAIL  
SCALE: NO SCALE

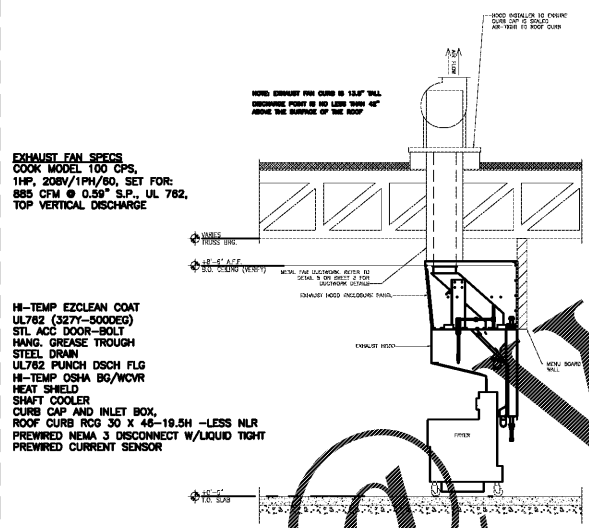

5a FRYER HOOD EXHAUST FAN DETAIL - FREESTANDING HOOD  
SCALE: NO SCALE

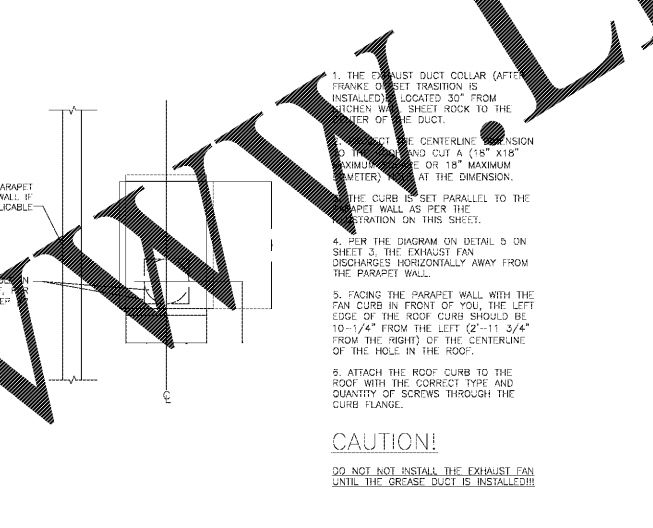

6 INSTRUCTIONS FOR TYPICAL MOUNTING OF THE ROOF CURB  
SCALE: NO SCALE

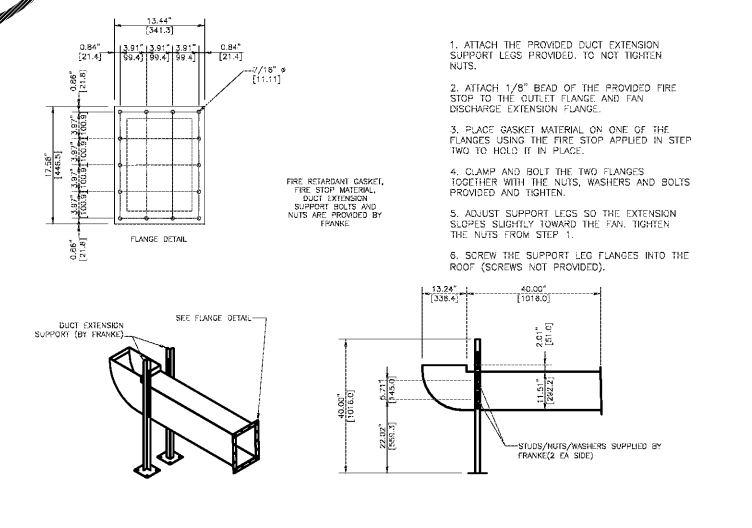

7 EXHAUST FAN EXTENSION DUCT DETAIL  
SCALE: NO SCALE

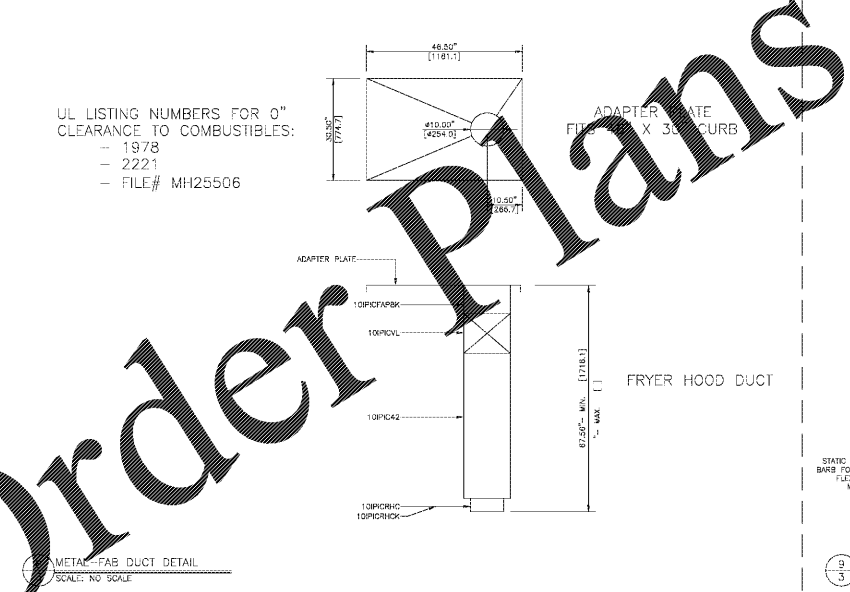

8 METAL-FAB DUCT DETAIL  
SCALE: NO SCALE

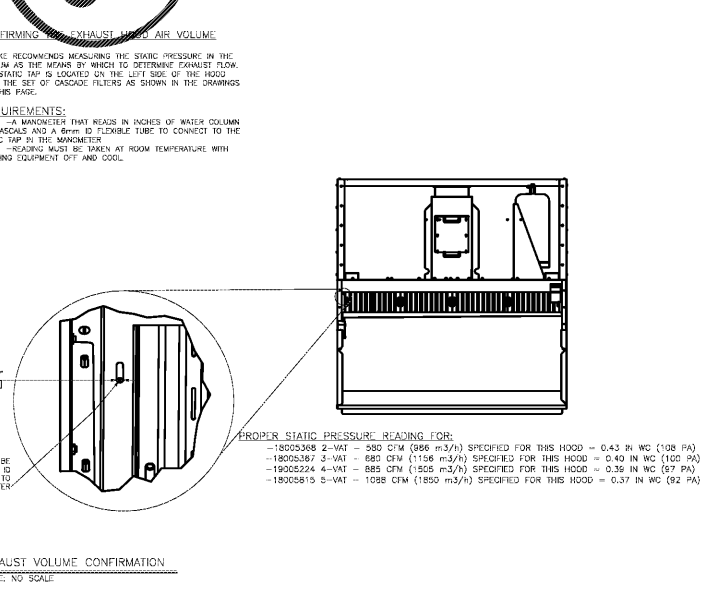

9 EXHAUST VOLUME CONFIRMATION  
SCALE: NO SCALE

IF:	THEN:					NOTES
	EXHAUST FAN	ELECTRIC POWER TO COOKING EQUIPMENT	MECHANICAL GAS VALVE	HVAC UNITS	MAKE-UP AIR UNITS (IF AVAILABLE)	
FAN SWITCH IS TURNED ON	ON	ON	ON	ON	ON	HVAC MUST BE ON FOR EXHAUST FAN TO OPERATE
FAN SWITCH IS TURNED OFF	OFF	OFF	ON	ON	OFF	
FIRE SUPPRESSION DISCHARGES	ON	OFF	OFF	OFF	OFF	
FAN BELT IS SLIPPING	ON	ON	ON	ON	OFF	POWER TO COOKING EQ. OFF VIA CURRENT SENSOR
FAN BELT IS BROKEN	ON	ON	ON	ON	OFF	POWER TO COOKING EQ. OFF VIA CURRENT SENSOR
LOSS OF POWER	OFF	OFF	ON	OFF	OFF	
HVAC IS SWITCHED OFF	OFF	OFF	ON	OFF	OFF	

10 CONTROL MATRIX  
SCALE: NO SCALE

Shane R. Hamilton P.E.  
CONSULTING ENGINEER  
1717 N. HOWARD AVENUE  
Tampa, FL 33607 (813) 251-6848

© Copyright 2018- Drawings, specifications, notes, database, computer files, field data, and reports as instruments of service prepared by the Design of Record. As instruments of services, these items remain the property of the Design of Record, who shall retain all statutory and other reserved rights, including the copyright thereto. Any use, reproduction or changes to these documents without written consent of NCA Consultants is a violation of federal copyright laws.