

Order Plans @

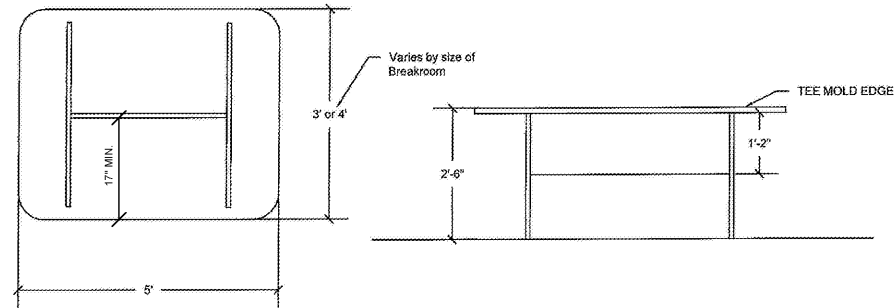

4 BREAK ROOM TABLE
A5.2 NOT TO SCALE

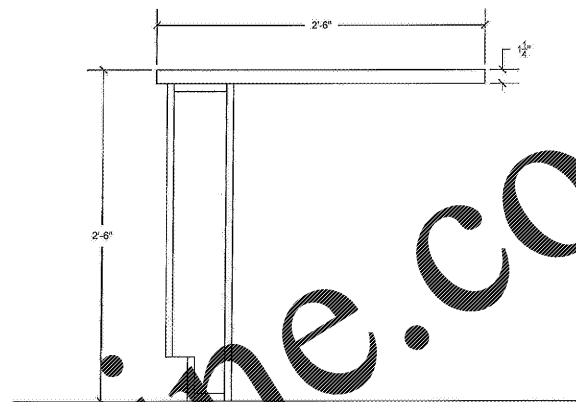

1 RECEPTION ACCESS. CHECK-IN
A5.2 NOT TO SCALE

ROUGH-IN DIMENSIONS

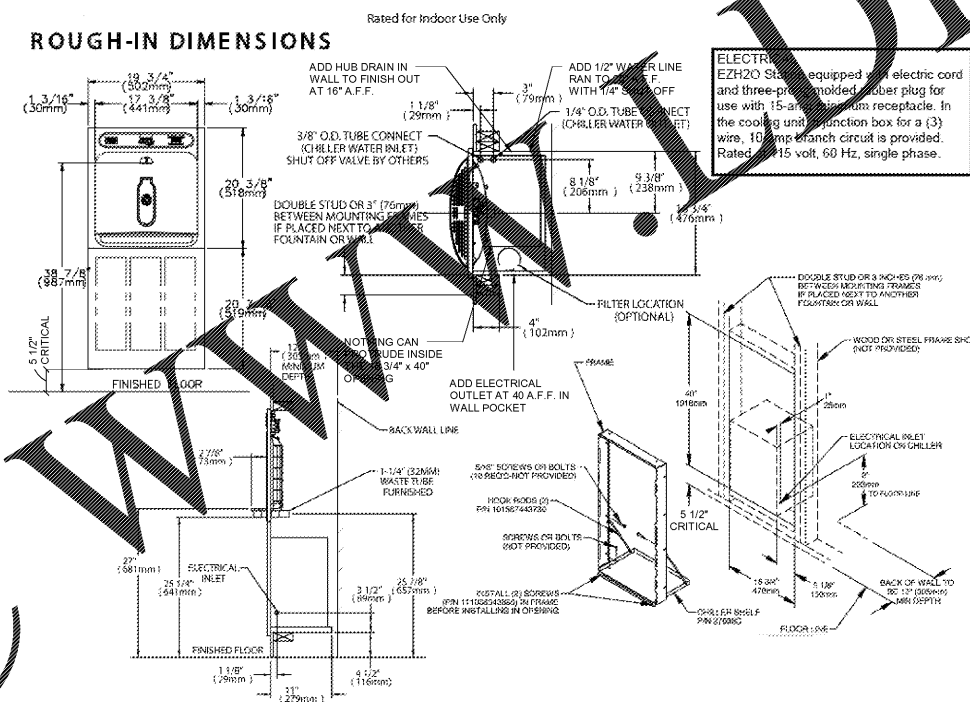

5 BOTTLE FILLING STATION DETAIL
A5.2 NOT TO SCALE

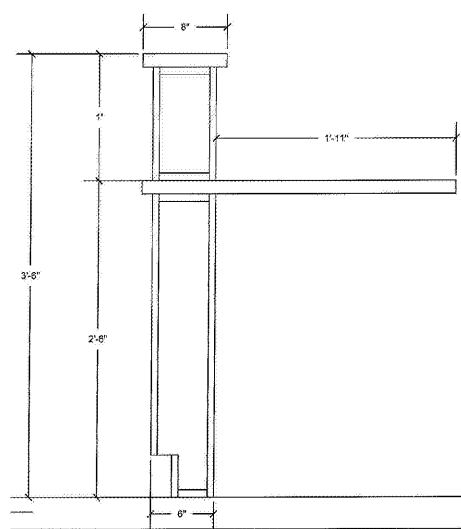

2 RECEPTION STAND UP CHECK-IN
A5.2 NOT TO SCALE

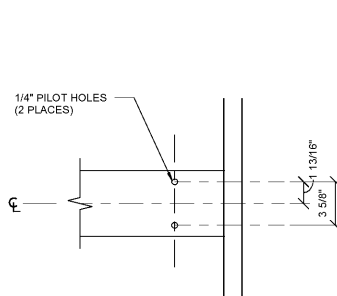

7 BLOCKING DETAIL
A5.2 NOT TO SCALE

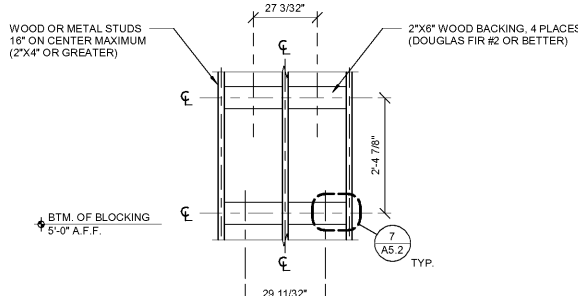

6 BLOCKING DETAIL
A5.2 NOT TO SCALE

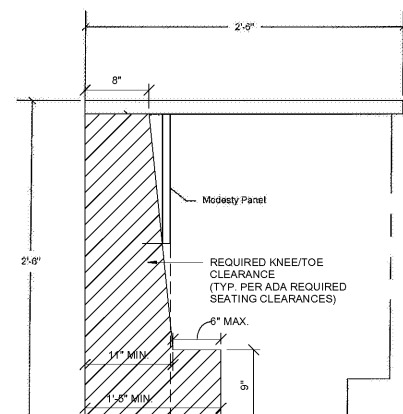

3 BUSINESS OFFICE SIT DOWN CHECK-OUT
A5.2 NOT TO SCALE

EXCEL
ARCHITECTS • ENGINEERS • SURVEYORS
1000 PINELOT DRIVE
FOUNTAIN LAKE, WI 54935
PHONE: (920) 926-9800
WWW.EXCELENGINEER.COM

COLLABORATION
AspenDental

PROJECT INFORMATION
PROJECT NUMBER 1823380

TENANT BUILD-OUT FOR:
ASPEN DENTAL
4011 WARDS ROAD • LYNCHBURG, VA 24502

PROFESSIONAL SEAL

SHEET DATES
SHEET ISSUE MAY 31, 2018

REVISIONS

SHEET INFORMATION
DETAILS
SHEET NUMBER
A5.2