

**BOWLERO - AUGUSTA**

ISSUE FOR PERMIT / BID

Client/Owner/Project Address

Bowlero | AMP  
Client Address  
222 Water Street  
New York, NY 10002

Project Address  
507 Washington Rd  
Augusta, GA 30907

Issue Drawing Log

2018.05.29 ISSUE FOR BID

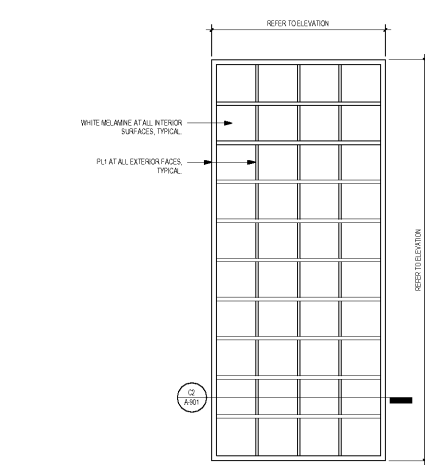

C1 SHOE CUBBY - ELEVATION  
3'-11 1/2"

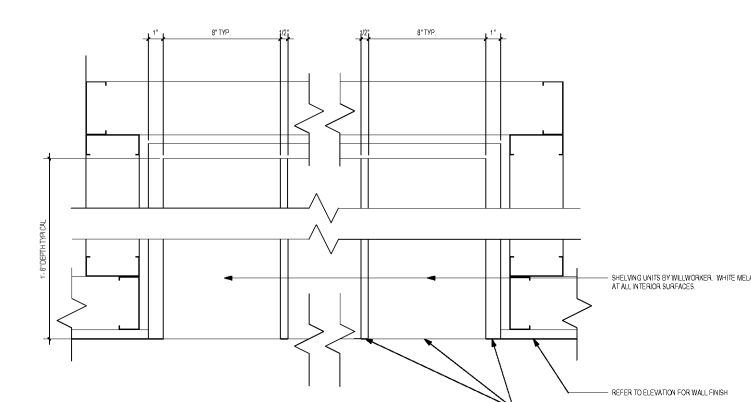

C2 SHOE CUBBY - PLAN DETAIL  
3'-11 1/2"

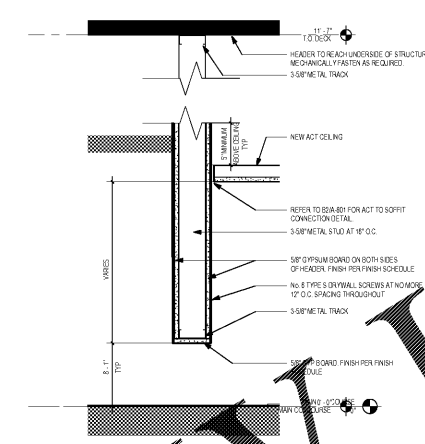

C3 CONCOURSE HEADER DETAIL  
3'-11 1/2"

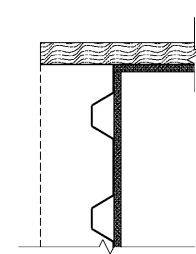

B1 METAL DECK - WATER FALL COUNTER DETAIL  
3'-11 1/2"

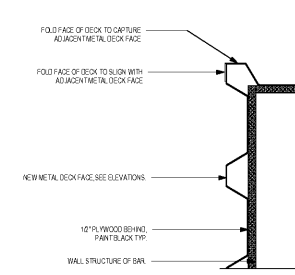

B2 METAL DECK - CORNER DETAIL HIGH  
3'-11 1/2"

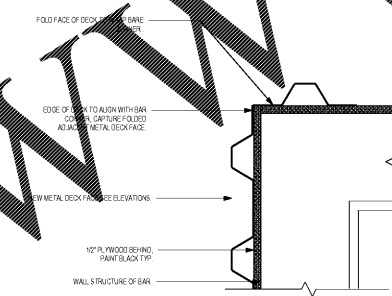

B3 METAL DECK - CORNER DETAIL LOW  
3'-11 1/2"

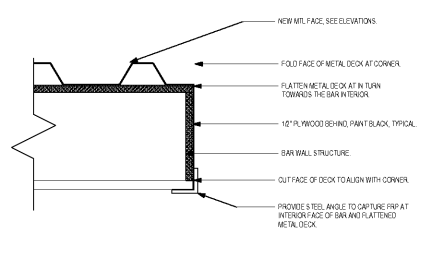

B4 METAL DECK - TERMINATION DETAIL  
3'-11 1/2"

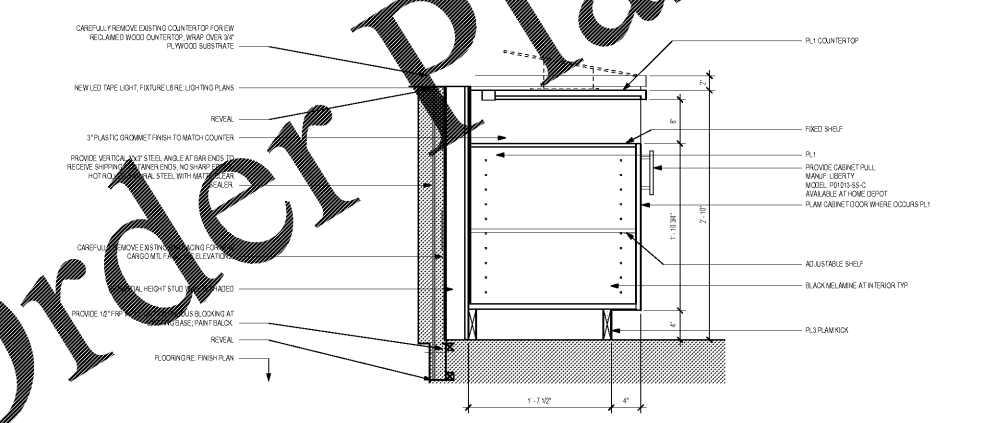

A1 SECTION - SHOE DECK POS NEW  
1'-10 1/2" x 4'

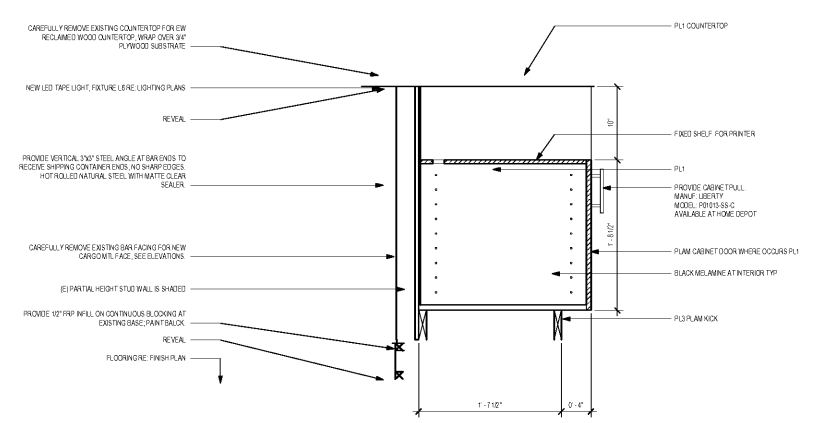

A2 SECTION - SHOE DESK PRINTER SHELF  
1'-10 1/2" x 4'

Order Plans @

WWW.LDILine.com

Sheet Identification  
**SHOE CARGO & OFFICE MILLWORK & DETAILS**

**A-901**