



MACON-BIBB COUNTY
RECREATION DEPARTMENT
115 Willie Smokie Glover Drive
Macon, Georgia 31201
Contact: Mr. Reggie Moore, Director

**WISE AVE.
PARK**



Vaughn & Melton
Consulting Engineers, Inc.
Engineering - Surveying
300 Chastain Center Blvd, Ste 325
Kennesaw, Georgia 30144
TEL: (770) 627-3590 FAX: (770) 627-3594
V&M Contact:
Paul Ken Hammon, PE (770) 639-7797
KENTUCKY NORTH CAROLINA
606-248-6600 828-253-2796
TENNESSEE SOUTH CAROLINA
865-546-5800 864-574-4775
www.vaughnandmelton.com
Copyright © 2015
All Rights Reserved

Schroeder Architects
ARCHITECTURE-MASTER PLANNING-INTERIORS
3118 East Shadowlawn Ave, NE
Atlanta, Georgia 30305
TEL: (404) 773-2826
email: david@schroeder-architects.com



Project Name: WISE AVENUE PARK
Project Number:
Drawn By: Ck'd By:
Date: Scale: As shown

Rev.	Description:	Date:
1.	SUBMITTED TO COUNTY	11/16/17
2.	REVISED PER COUNTY COMMENTS	03/12/18

**CONSTRUCTION
DETAILS**

D-03

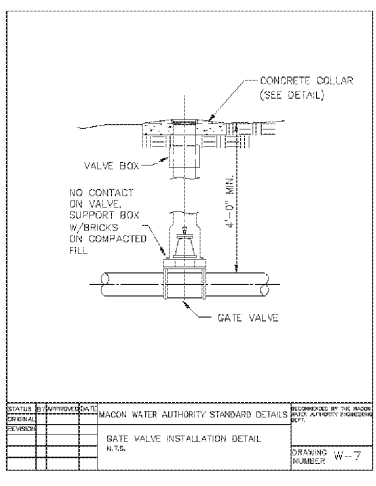
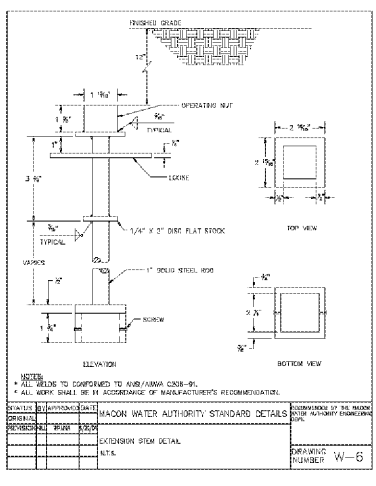
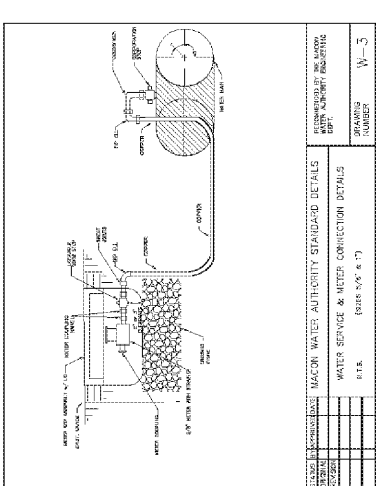
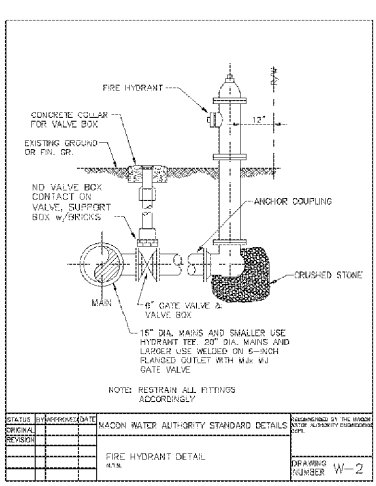
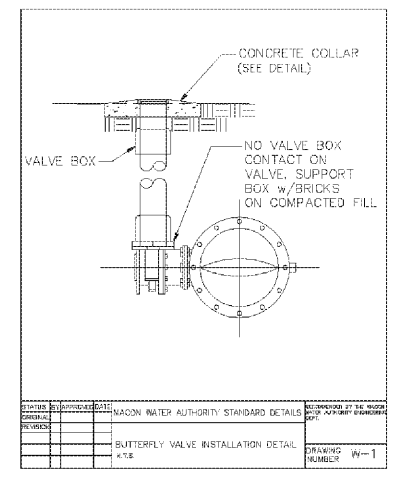

SECTION

MAIN DIA	A	B	C	D	E	STEEL REINFORCING
36"	2'-0"	10'-0"	10'-0"	2'-0"	2'-0"	#9 @ 8" O.C. E.W.E.F.
24"	1'-9"	9'-0"	9'-0"	2'-0"	2'-0"	#9 @ 8" O.C. E.W.E.F.
20"	1'-6"	7'-8"	7'-8"	2'-0"	2'-0"	#9 @ 12" O.C. E.W.E.F.
16"	1'-3"	6'-8"	6'-8"	1'-0"	1'-0"	#9 @ 12" O.C. E.W.E.F.
12"	1'-2"	5'-3"	5'-3"	1'-0"	1'-0"	#7 @ 12" O.C. E.W.E.F.
8" or 6"	1'-0"	4'-0"	4'-0"	0'-8"	0'-8"	#5 @ 12" O.C. E.W.E.F.

TEST PRESSURE: 250 P.S.I.
SOIL BEARING PRESSURE: 3000 P.S.F.

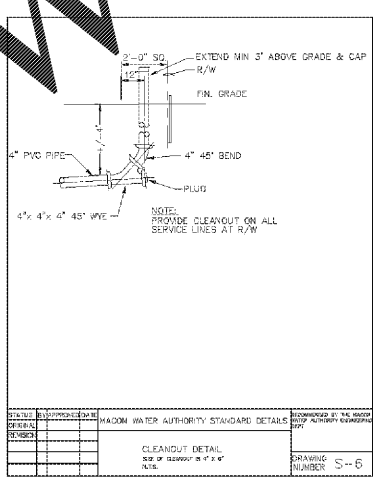
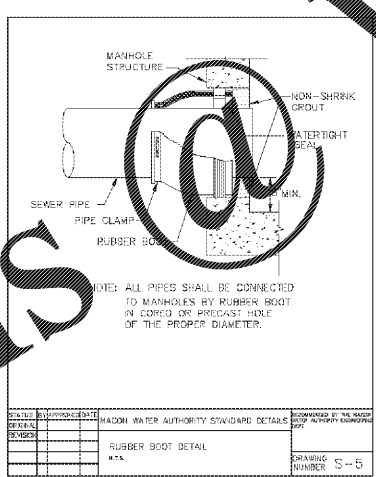
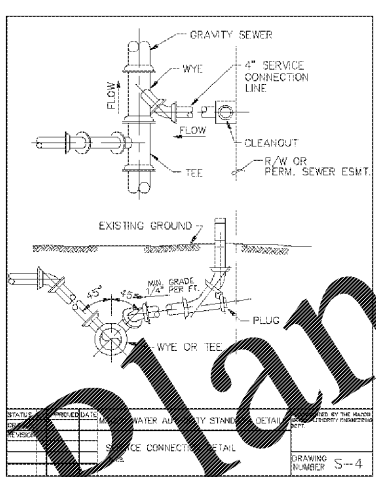
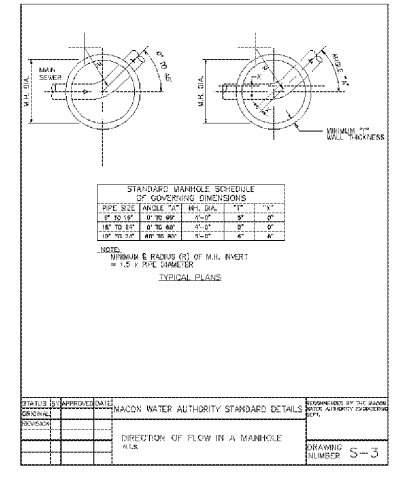
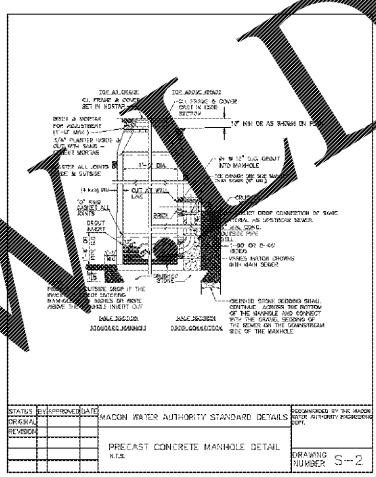
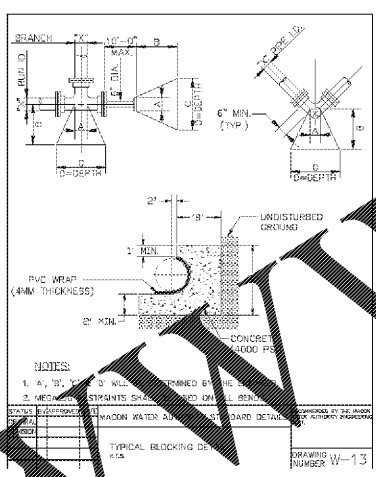
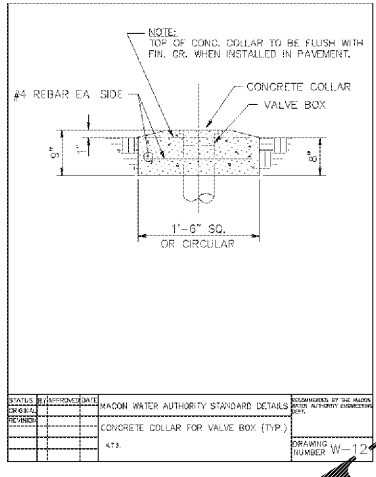
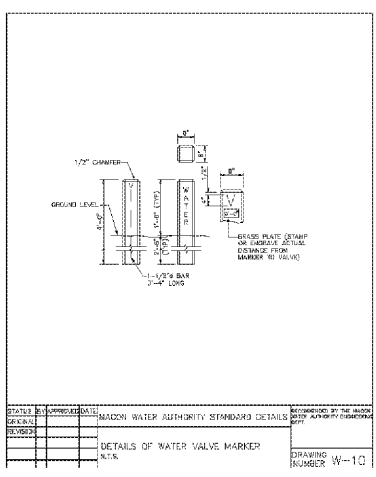

Order Plans

WWW.M&M.DI.Line.COM