

CLIP AND CHANNEL OPTION

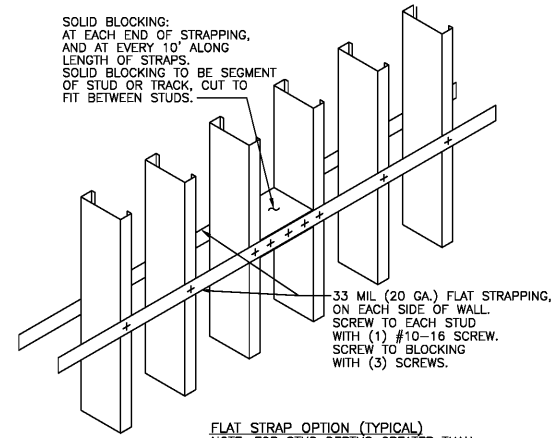

FLAT STRAP OPTION (TYPICAL)
NOTE: FOR STUD DEPTHS GREATER THAN 6" THIS DETAIL MUST BE USED

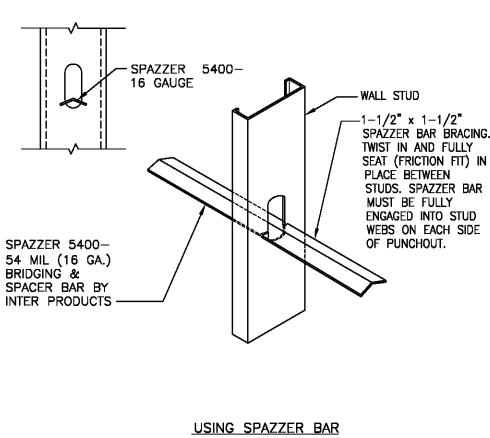

USING SPAZZER BAR

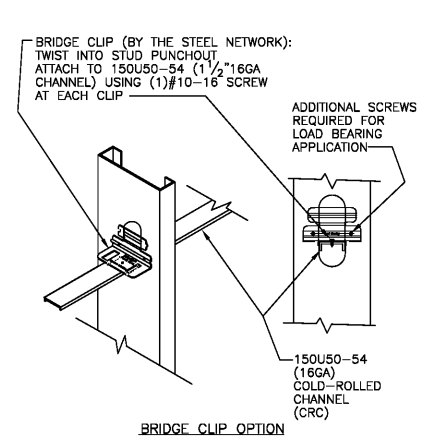

BRIDGE CLIP OPTION

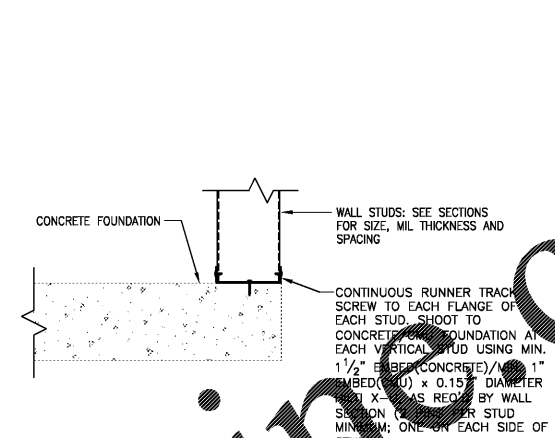

SECTION DETAIL: TRACK TO SLAB

FOUR OPTIONS FOR WALL STUD LATERAL BRACING

NOT TO SCALE

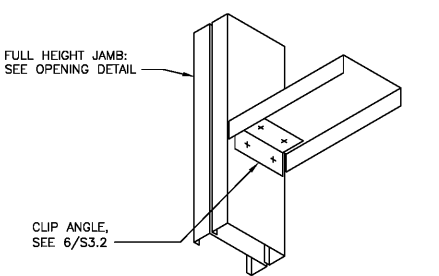

TYPICAL CONNECTION SILL TO JAMB (HEAD SIMILAR)

NOT TO SCALE

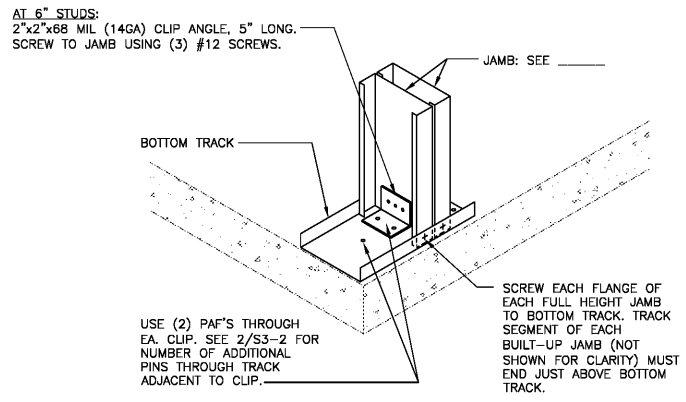

JAMB TO SLAB AT OPENINGS

NOT TO SCALE

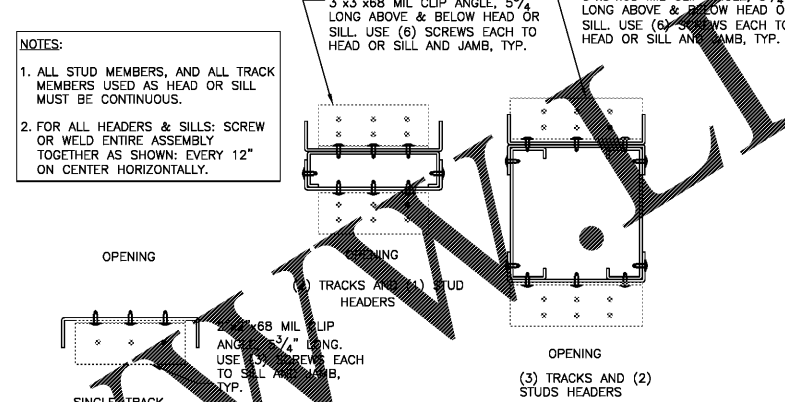

SECTION AT TYPICAL HEAD AND SILL

NOT TO SCALE

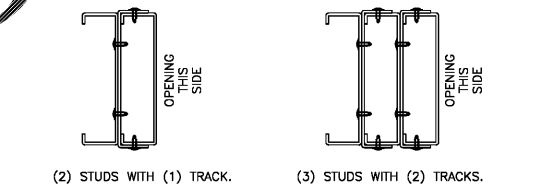

JAMB CONFIGURATION

NOT TO SCALE

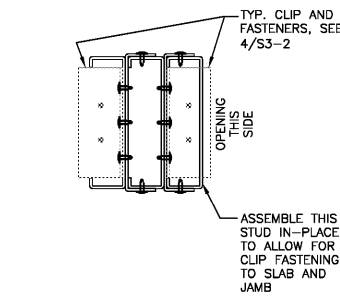

CLIPS AT (3) STUD JAMB

NOT TO SCALE

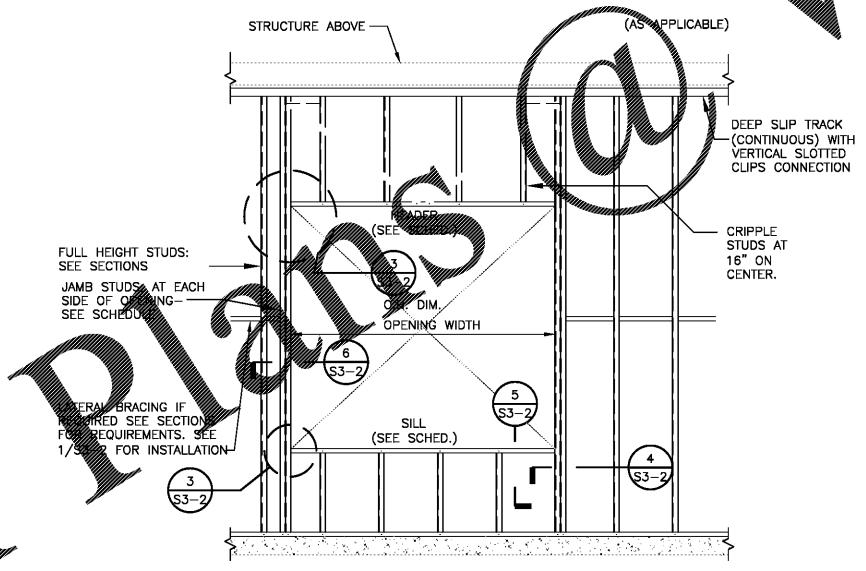

TYPICAL OPENING AT WINDOW (SIM. DOORS)

NOT TO SCALE

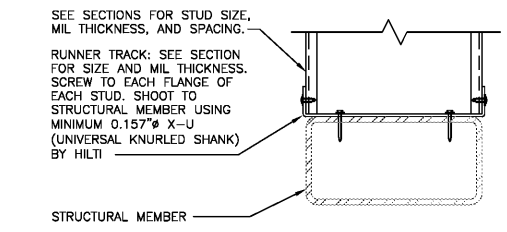

SECTION DETAIL: TRACK TO STRUCTURAL STEEL

NOT TO SCALE

- JAMBS:**
UP TO 4'-0" OPENING WIDTH- (2) STUDS WITH (1) TRACK.
UP TO 6'-8" OPENING WIDTH- (3) STUDS WITH (2) TRACKS.
- HEADER:**
UP TO 4'-0" OPENING WIDTH- (2) TRACKS AND (1) STUD.
UP TO 6'-8" OPENING WIDTH- (3) TRACKS AND (2) STUDS.
- SILL:**
UP TO 4'-0" OPENING WIDTH- SINGLE TRACK.
UP TO 6'-8" OPENING WIDTH- (2) TRACKS AND (1) STUD.

ARCHITECT'S STAMP
STATE OF GEORGIA
SMITH DESIGN GROUP, INC.
7575
REGISTERED ARCHITECT
SIGNATURE REQUIRED
2 WEST WALTON STREET
ATLANTA, GEORGIA 30240
770-882-5511 www.SDGarch.net

REVISIONS	
DATE	DESCRIPTION

PROJECT:
VERNON ROAD FIRE STATION
VERNON ROAD
LAGRANGE GEORGIA

TITLE:
SECTIONS AND DETAILS

MODIFIED DATE:	JOB NO: 1731
ISSUED DATE: FOR BID AND PERMIT 7 MAY 2018	SHEET: S3-2

SBFA JOB # 18034.01
SHARZER BRADY FACH ASSOCIATES, INC.
CONSULTING STRUCTURAL ENGINEERS
2337 PERIMETER PARK SUITE 215
ATLANTA, GEORGIA 30341
PHONE: (770) 455-3404, FAX: (770) 451-1415
COPYRIGHT © SHARZER BRADY FACH ASSOCIATES, INC. 2018

Order Plans @

WWW.WELDDILING.COM