



SIGNATURE REQUIRED

SMITH DESIGN GROUP, INC.

200 WEST WILKINSON STREET
LAGRANGE, GEORGIA 30240
706-882-5511 www.SDGarch.net

ERECTION NOTES:
ALL ANCHOR BOLTS SHALL HAVE A 3 INCH PROJECTION (UNLESS NOTED) ABOVE THE BOTTOM OF THE COLUMN BASE PLATES, EXCEPT 1/2 INCH DIAMETER BOLTS LOCATED AT DOORS WHICH SHALL HAVE PROJECTION OF 1 INCH.
ALL BOLTS SHALL HAVE A MINIMUM THREAD LENGTH 0 1/4 INCH LESS THAN THE PROJECTION. THE PROJECTIONS SPECIFIED PROVIDE FOR A SINGLE BASE PLATE THICKNESS AND APPLICATION OF ONE 1/4 INCH WASHER AND ONE HEAVY HEX NUT. IN THE INSTALLED POSITION, THE TOP OF THE ANCHOR BOLT MUST BE FLUSH WITH OR ABOVE THE TOP OF THE NUT. ADDITIONAL PROJECTION LENGTH MUST BE CONSIDERED AND PROVIDED FOR ITEMS SUCH AS GROUT, DOUBLE NUTS, PLATE, WASHERS, LEVELING PLATES, ETC., THAT MAY BE SPECIFIED BY OTHERS. PROJECTING THREADS SHOULD BE GREASED OR OTHERWISE PROTECTED FROM CORROSION.

KEYNOTES

- ① METAL WALL PANEL
- ② 6" BATT OR 6" ROLLED INSULATION
- ③ INTERIOR LINER PANEL @ 14" O.C. ON EXTERIOR WALLS. STAY AREA PROVIDED TO ATTACH LINER PANELS
- ④ PEMB COLUMN
- ⑤ 16" O.C.
- ⑥ 1/2" LAYERS OF TYPE 'X' GYPSUM BOARD
- ⑦ ONE LAYER OF 5/8" TYPE 'X' GYPSUM BOARD
- ⑧ 8" WALL STUD
- ⑨ 2X4 STUD BLOCKING AROUND COLUMN
- ⑩ 1/2" PLYWOOD SHEATHING AND 20 MIL ICE AND WATER SHIELD (SELF-ADHERING)
- ⑪ TS 6" X 12" (SEE STRUCTURAL DETAILS) PROVIDE ALUMINUM CLOSURE COVER ALL AROUND TUBE STEEL TO MATCH ALUMINUM STOREFRONT
- ⑫ 4" X 12" ALUMINUM STOREFRONT WITH SUBSILL AND 1" INSULATED GLASS
- ⑬ 7/8" HAT CHANNELS @ 16" O.C. WITH 5/8" GYP. BRD.
- ⑭ ALUMINUM STOREFRONT DOOR

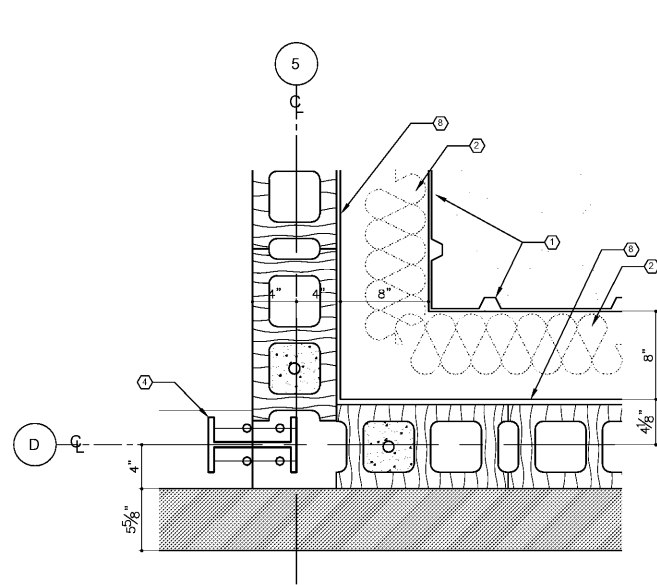

1 COLUMN DETAIL
AS-3 SCALE: 1-1/2" = 1'-0"

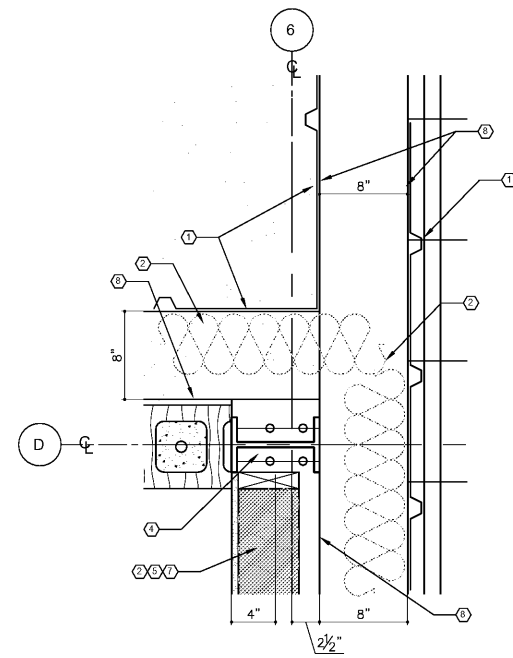

2 COLUMN DETAIL
AS-3 SCALE: 1-1/2" = 1'-0"

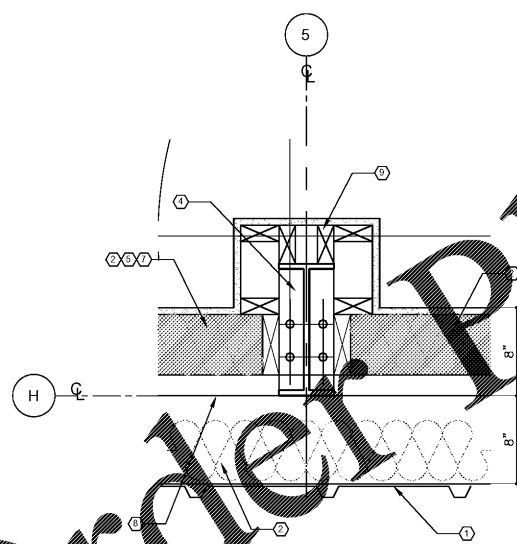

3 COLUMN DETAIL
AS-3 SCALE: 1-1/2" = 1'-0"

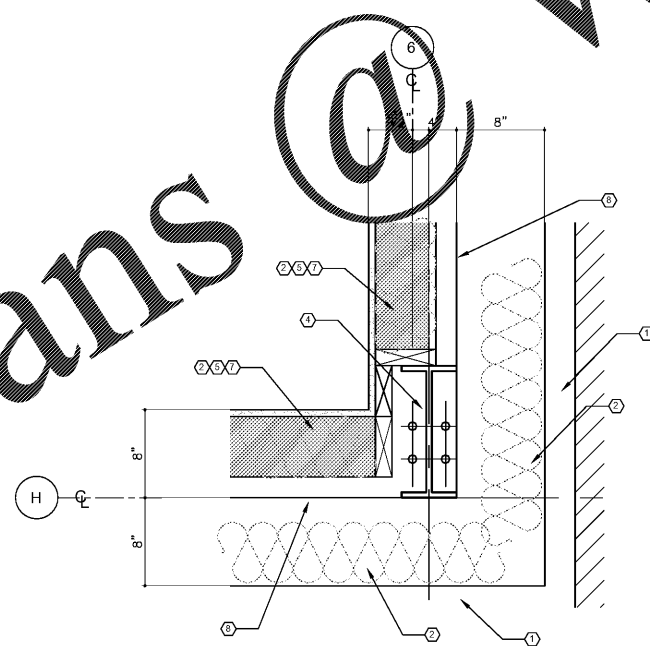

4 COLUMN DETAIL
AS-3 SCALE: 1-1/2" = 1'-0"

REVISIONS	
DATE	DESCRIPTION

PROJECT:
VERNON ROAD FIRE STATION
VERNON ROAD
LAGRANGE GEORGIA

TITLE:
ARCHITECTURAL
STRUCTURAL DETAILS

MODIFIED DATE:	JOB NO: 1731
ISSUED DATE: FOR BID AND PERMIT 07 MAY 2018	SHEET: AS-3

Order Plans @ WWW.LDOnline.com