

SMITH DESIGN GROUP, INC.
 200 WEST HAWKSON STREET
 LAGRANGE, GEORGIA 30240
 770-482-5511 www.SDGarch.net

KEYNOTES

- 1 DATA RECEPTACLE
- 2 POWER RECEPTACLE DUPLEX (GFI WITHIN 48" OF WATER)
- 3 1/2" PLYWOOD W/ 1/2" SOLID SURFACE FULL BACKSPLASH TO MATCH COUNTERTOP
- 4 3" GROMMETT (VERIFY LOCATION WITH OWNER)
- 5 SOLID SURFACE COUNTERTOP
- 6 FUR DOWN ABOVE OVERHEAD CABINETS WITH 1 5/8" M.S. @ 16" O.C. AND 5/8" GYP. BOARD PAINT.
- 7 4" RESILIENT BASE
- 8 GFI OUTLET @ 48" A.F.F.
- 9 PROVIDE 4" SKIRT AT BOTTOM OF OVERHEAD CABINET TO COVER UNDER CABINET LIGHTS. SEE DETAIL A4-B.
- 10 4" SOLID SURFACE BACKSPLASH

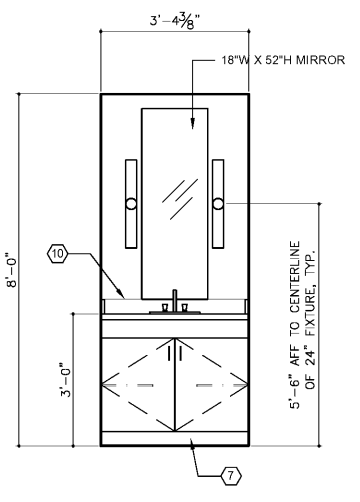

1 SPACE - 108 BATH
 SCALE: 1/2" = 1'-0"

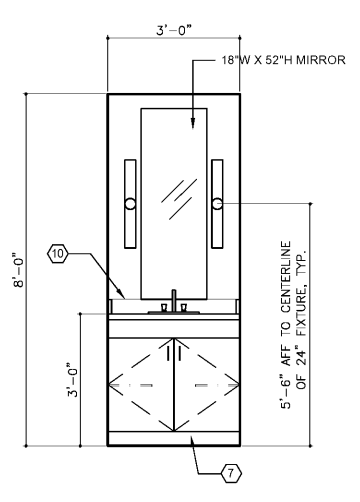

2 SPACE - 215 BATH
 SCALE: 1/2" = 1'-0"

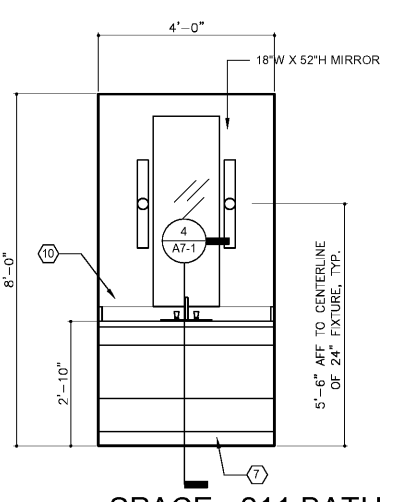

3 SPACE - 211 BATH
 ACCESSIBLE VANITY
 SCALE: 1/2" = 1'-0"

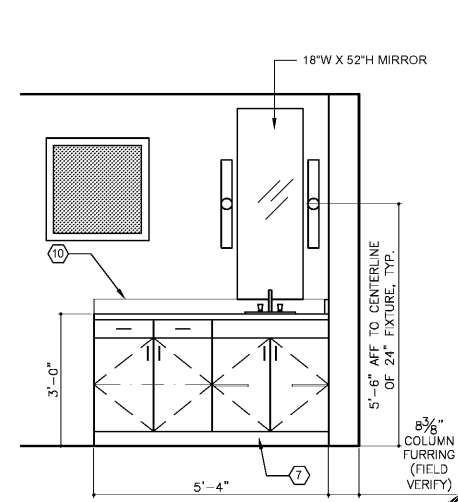

4 SPACE - 202 BATH
 SCALE: 1/2" = 1'-0"

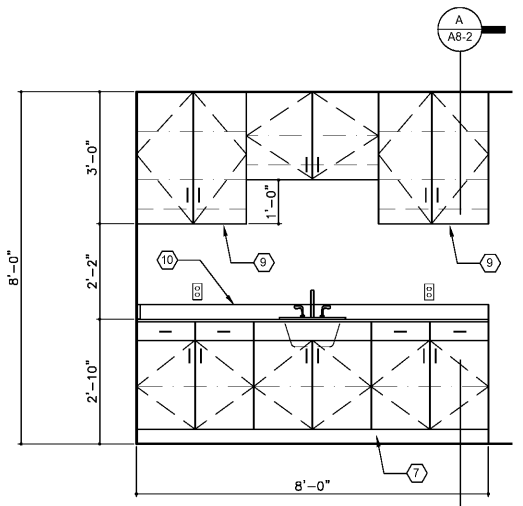

5 SPACE - 110 DECON
 SCALE: 1/2" = 1'-0"

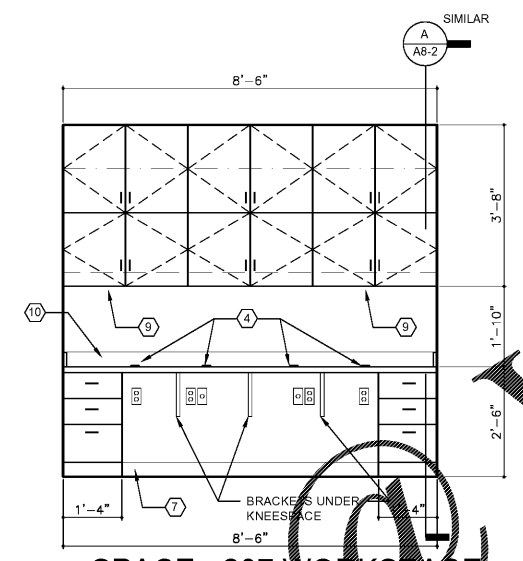

6 SPACE - 207 WORKSPACE
 SCALE: 1/2" = 1'-0"

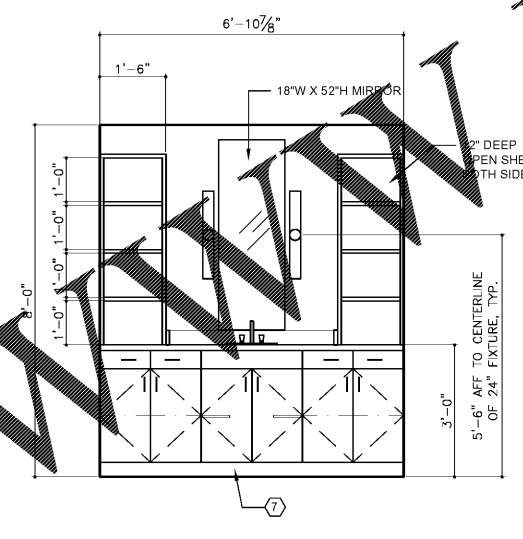

7 SPACE - 210 BATH
 SCALE: 1/2" = 1'-0"

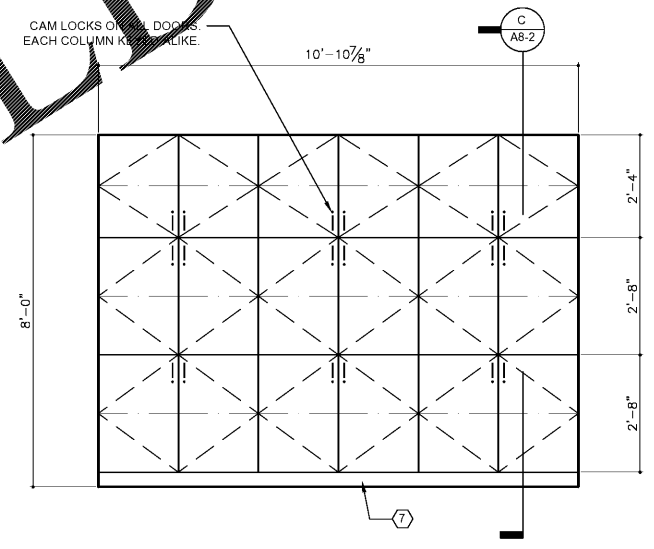

8 KITCHEN PANTRY CABINETS
 SCALE: 1/2" = 1'-0"

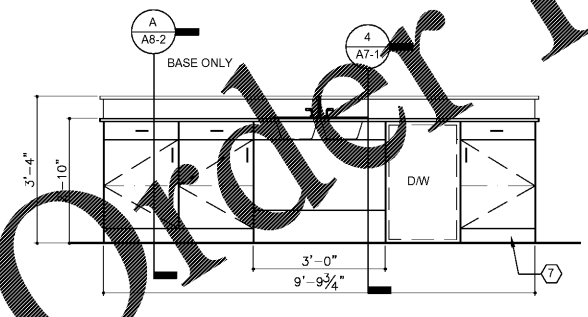

9 KITCHEN ISLAND
 SCALE: 1/2" = 1'-0"

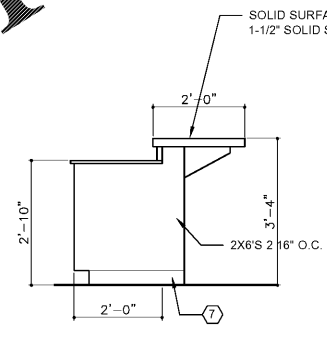

10 KITCHEN ISLAND
 SCALE: 1/2" = 1'-0"

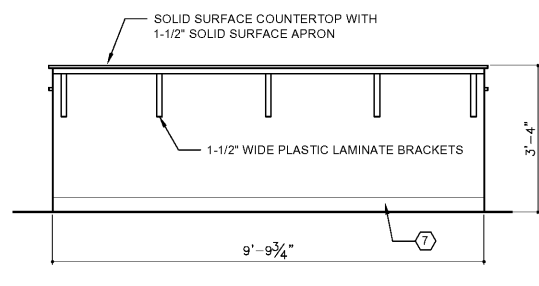

11 KITCHEN ISLAND
 SCALE: 1/2" = 1'-0"

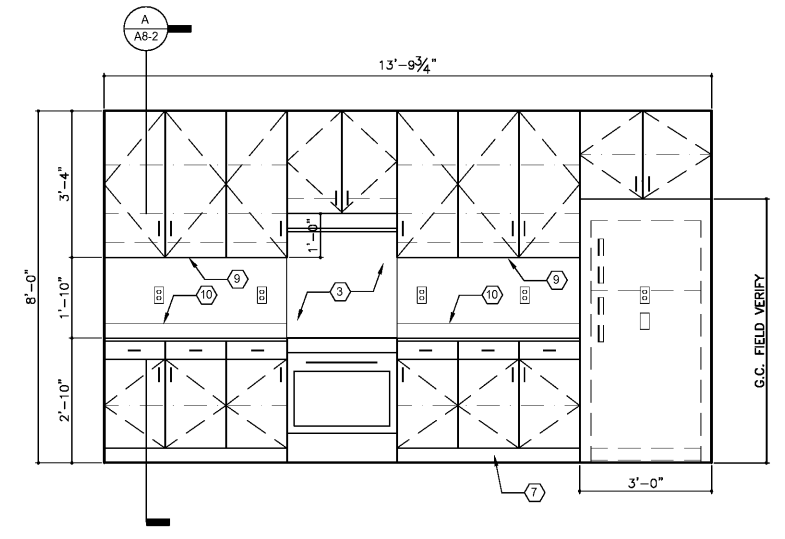

12 SPACE - 218 KITCHEN
 SCALE: 1/2" = 1'-0"

REVISIONS	
DATE	DESCRIPTION

PROJECT:
 VERNON ROAD FIRE STATION
 VERNON ROAD
 LAGRANGE GEORGIA

TITLE:
 CABINERY ELEVATIONS

MODIFIED DATE:	JOB NO: 1731
ISSUED DATE: FOR BID AND PERMIT 07 MAY 2018	SHEET: A8-3

Order Plans

www.LDILine.com