

1
A2-9
HEAD - WINDOW
SCALE: 3" = 1'-0"
DOORS AND JAMB SIMILAR
ADD. ALT. NO.2

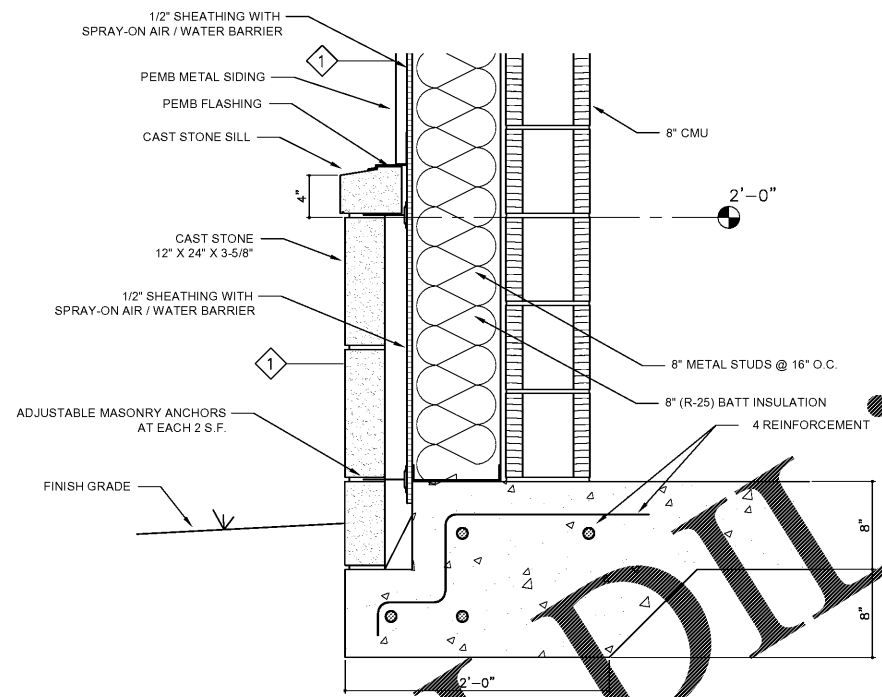

3
A2-9
ADD. ALT. NO.1
SCALE: 1-1/2" = 1'-0"

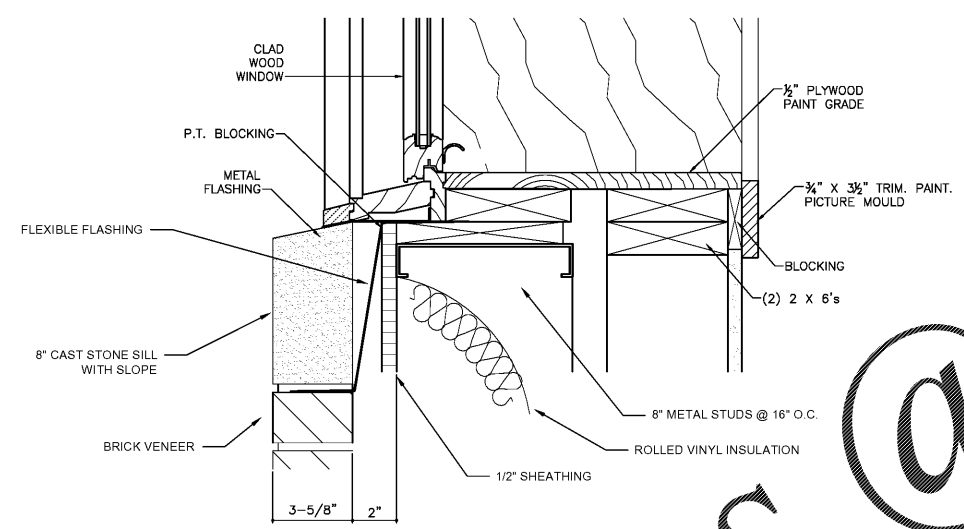

2
A2-9
SILL - WINDOW
SCALE: 3" = 1'-0"
ADD. ALT. NO.2

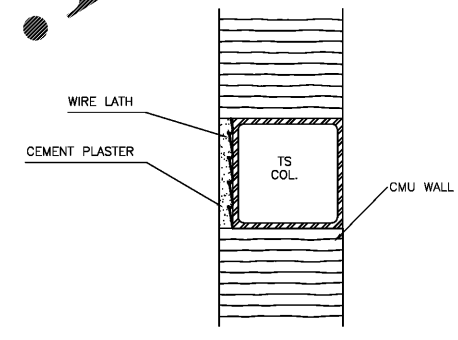

A
A2-9
COLUMN DETAIL
SCALE: 3" = 1'-0"
USE WHERE COLUMN IS EXPOSED TO VIEW

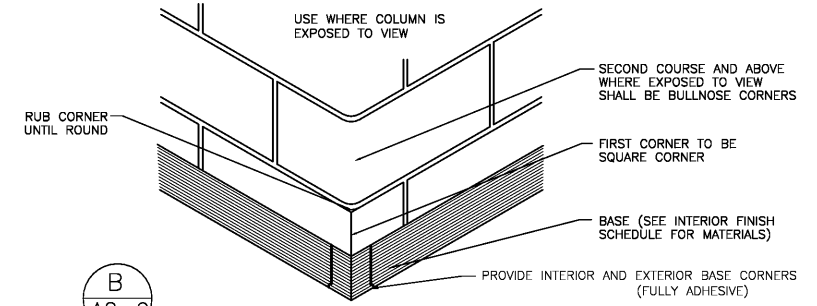

B
A2-9
TYPICAL INTERIOR CORNER DETAIL
SCALE: 1 1/2" = 1'-0"

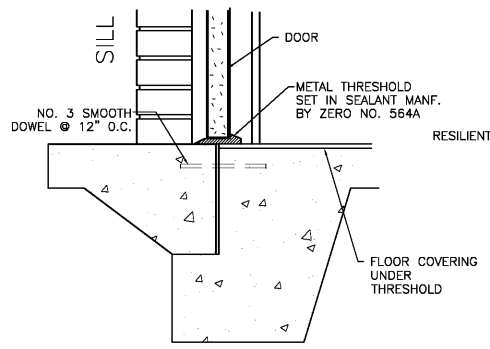

1

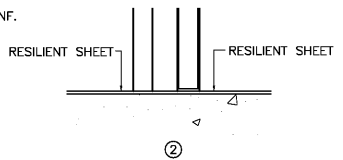

2

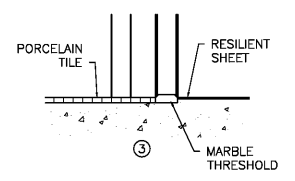

3

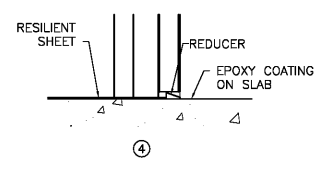

4

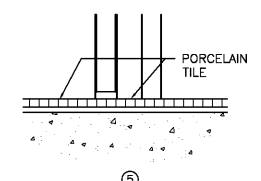

5

HEAD AND JAMB DETAILS AND DOOR SILL CONDITIONS
SCALE: 1 1/2" = 1'-0"

ARCHITECT'S STAMP

 SIGNATURE REQUIRED
SMITH DESIGN GROUP, INC.
 20 WEST HAWKSON STREET
 LAGRANGE, GEORGIA 30240
 706-882-5511 www.SDGarch.net

REVISIONS	
DATE	DESCRIPTION

PROJECT:
VERNON ROAD FIRE STATION
 VERNON ROAD
 LAGRANGE GEORGIA

TITLE:
JAMB DETAILS

MODIFIED DATE:	JOB NO: 1731
ISSUED DATE: FOR BID AND PERMIT	SHEET: A2-9
07 MAY 2018	

Order Plans

WWW.LDILine.com