

NOTE:
THE CRITICAL ROOT ZONE (CRZ) OF A TREE IS WHERE THE MAJORITY OF A TREE'S ROOTS LAY. 85% OF MOST TREE ROOTS ARE FOUND IN THE TOP 24" OF THE SOIL AND SUPPLY THE MAJORITY OF NUTRIENTS AND WATER. GENERALLY, ROOTS SPREAD OUT 2-3X THE HEIGHT OF THE TREE.

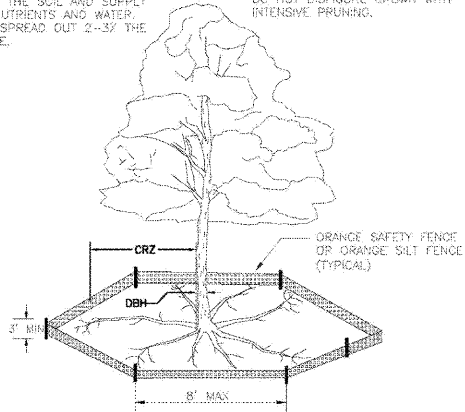

NOTE:
CROWN OF THE TREE IS NEEDED FOR LEAF GROWTH TO PRODUCE OXYGEN. FILTER THE AIR, REDUCE WIND AND SOFTEN NOISE. DO NOT DISFIGURE CROWN WITH INTENSIVE PRUNING.

- NOTES:
1. PROTECT CRITICAL ROOT ZONE (CRZ) OF TREES PRIOR TO CONSTRUCTION. CLEARLY MARK THE TREES AND ERECT A PROTECTIVE BARRIER AT THE CRZ. BARRIER SHALL BE MAINTAINED UNTIL CONSTRUCTION IS COMPLETE.
 2. CRZ RADIUS IS 1 FT PER INCH OF TREE DIAMETER AT BREAST HEIGHT (DBH).
 3. IF CONSTRUCTION OCCURS WITHIN THE CRZ, AT LEAST 12" OF MULCH AND/OR LOGGING MATS SHALL BE PLACED WHERE MACHINERY MANEUVERS TO REDUCE SOIL COMPACTION IN THIS ZONE.
 4. WHERE SIDEWALKS AND PATHWAYS PASS WITHIN CRZ, EXTRA CARE SHALL BE TAKEN TO AVOID DAMAGE TO THE ROOTS. ALTERNATE CONSTRUCTION METHODS, SUCH AS A REINFORCED SIDEWALK, SHALL BE IMPLEMENTED AS NECESSARY.
 5. FOR ALL TREES, CLIPPING OF LARGE STRUCTURAL ROOTS LOCATED NEAR THE BASE OF THE TRUNK IS PROHIBITED. DO NOT COMPACT SOIL BENEATH TREES. NO VEHICLE SHALL BE ALLOWED TO PARK UNDER TREES. NO MATERIALS OR EQUIPMENT SHALL BE STORED BENEATH TREES. DAMAGING THE BARK WITH LAWNMOWERS, CONSTRUCTION EQUIPMENT, OR ANYTHING ELSE IS PROHIBITED. CONTRACTOR SHALL REPAIR DAMAGE TO TREES.
 6. FAILING TO INSTALL OR MAINTAIN PROTECTION MEASURES SHALL RESULT IN A STOP WORK ORDER AND FINE OF \$500/DAY. DISTURBANCE OTHER THAN THAT ALLOWED ON THE APPROVED PLAN WILL REQUIRE OWNER TO POST A LETTER OF CREDIT FOR 3 YRS FOR TREE MITIGATION.

STANDARD DETAIL

TREE PROTECTION DURING CONSTRUCTION

SHEET 1 of 2

DATE: JAN, 2015

DRAWN BY: JSR

CHECKED BY: RDS, P.E.

SCALE: NOT TO SCALE

CITY OF WILMINGTON NORTH CAROLINA
CITY OF WILMINGTON ENGINEERING
PO BOX 1810
WILMINGTON, NC 28402
(910) 341-7807

SD 15-09

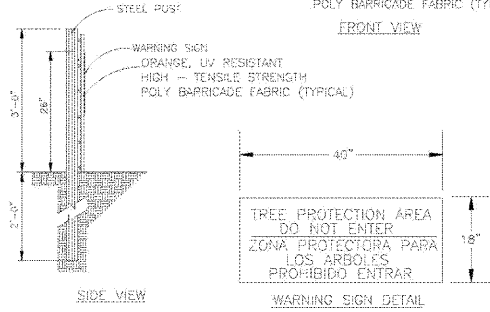
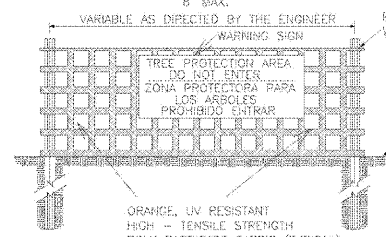

NOTES:

1. THE TREE PROTECTION FENCING SHALL NOT BE VIOLATED FOR THE ENTIRE DURATION OF THE PROJECT WITHOUT APPROVAL FROM URBAN FORESTRY STAFF.
2. WARNING SIGNS TO BE MADE OF DURABLE, WEATHERPROOF MATERIAL. LETTERS TO BE 3" HIGH, MINIMUM, CLEARLY LEGIBLE AND SPACED AS DETAILED.
3. SIGNS SHALL BE PLACED AT 50' MAXIMUM INTERVALS. PLACE A SIGN AT EACH END OF LINEAR TREE PROTECTION AND 50' ON CENTER THEREAFTER. FOR TREE PROTECTION AREAS LESS THAN 100' IN PERIMETER, PROVIDE NO LESS THAN TWO SIGNS PER PROTECTION AREA.
4. ATTACH SIGNS SECURELY TO FENCE POSTS AND FABRIC. MAINTAIN TREE PROTECTION FENCE AND SIGNS THROUGHOUT DURATION OF PROJECT.
5. TREE PROTECTION FENCING AND SIGNAGE SHALL BE REMOVED AFTER CONSTRUCTION.
6. ADDITIONAL SIGNS MAY BE REQUIRED BY CITY OF WILMINGTON, BASED ON ACTUAL FIELD CONDITIONS.

STANDARD DETAIL

TREE PROTECTION DURING CONSTRUCTION

SHEET 2 of 2

DATE: JAN, 2015

DRAWN BY: JSR

CHECKED BY: RDS, P.E.

SCALE: NOT TO SCALE

CITY OF WILMINGTON NORTH CAROLINA
CITY OF WILMINGTON ENGINEERING
PO BOX 1810
WILMINGTON, NC 28402
(910) 341-7807

SD 15-09

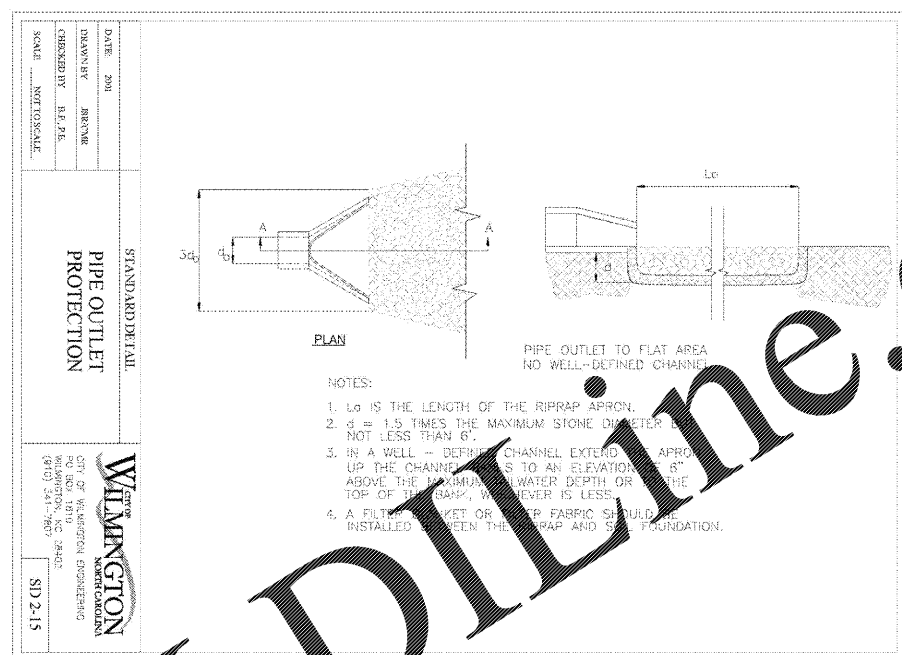

NOTES:

1. ENTRANCE(S) TO BE LOCATED TO PROVIDE MAXIMUM UTILITY BY ALL CONSTRUCTION VEHICLES.
2. RADIUS SHOULD ACCOMMODATE LARGE TRUCKS TO BE PROVIDED.
3. MUST BE MAINTAINED IN A CONDITION WHICH WILL PREVENT TRACKING OR DIRECT FLOW OF MUD ON TO THE PERIODIC TOPRESSING WITH STONE WILL BE NECESSARY. CONTRACTOR SHALL MAINTAIN NECESSARY.
4. ANY MATERIAL WHICH FALLS ONTO THE ROAD MUST BE CLEANED UP IMMEDIATELY.
5. FREQUENT CHECKS OF THE ENTRANCE(S) AND TIMELY MAINTENANCE SHALL BE PROVIDED.
6. NOTES ARE APPLICABLE AT ALL POINTS OF INGRESS AND EGRESS UNTIL SITE IS STABILIZED.

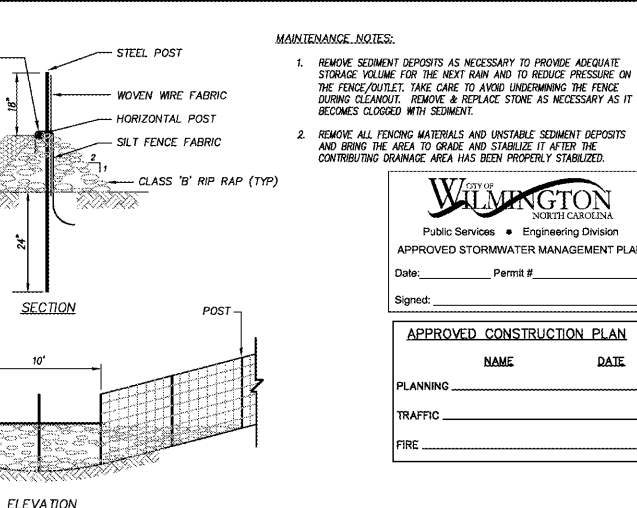
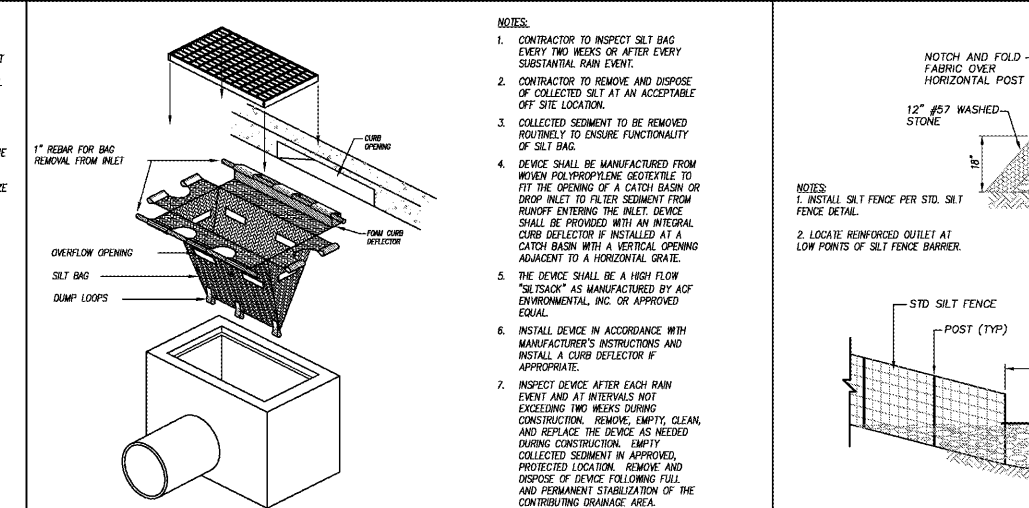
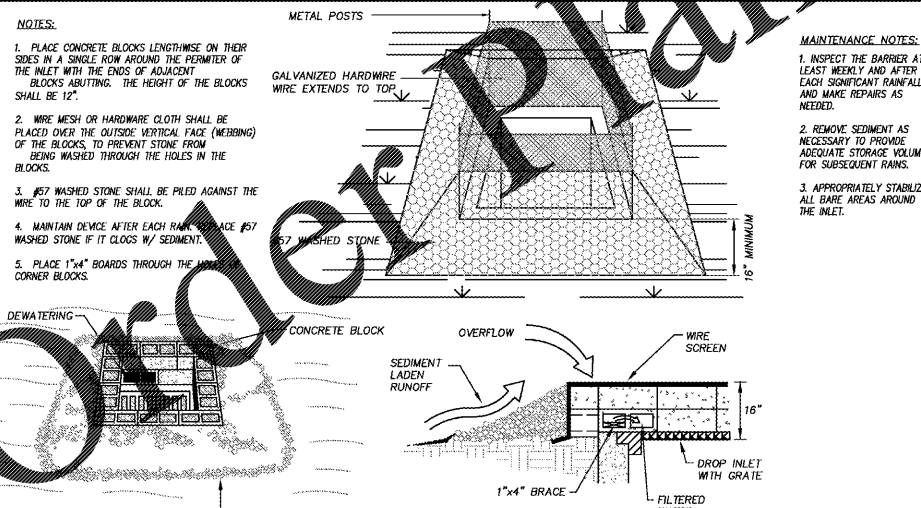
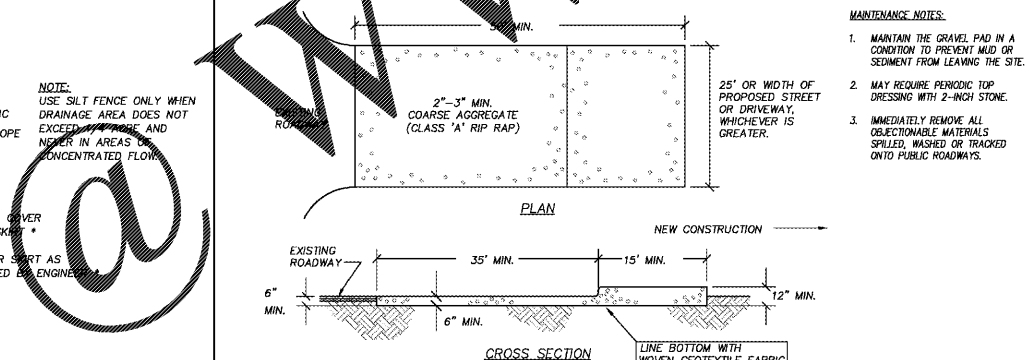
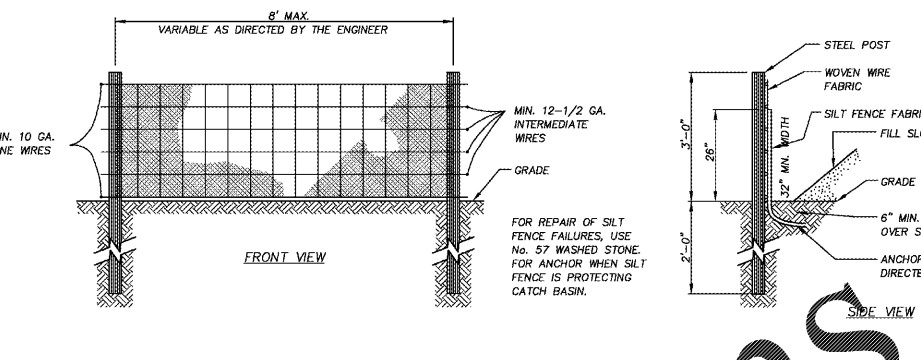
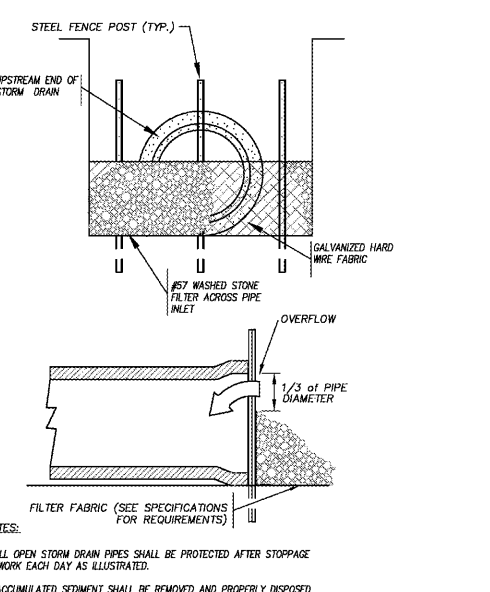
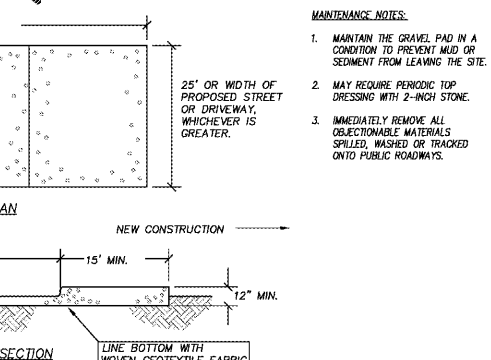

CITY OF WILMINGTON STANDARD DETAILS N.T.S.

DATE: JAN, 2015

DRAWN BY: JSR

CHECKED BY: RDS, P.E.

SCALE: NOT TO SCALE

CITY OF WILMINGTON NORTH CAROLINA
CITY OF WILMINGTON ENGINEERING
PO BOX 1810
WILMINGTON, NC 28402
(910) 341-7807

SD 15-09

WILMINGTON, NC

HAYNES / LACEWELL
POLICE AND FIRE
TRAINING FACILITY
3100 HURST STREET WILMINGTON, NC 28405

DESIGNER

CLARK NEXSEN

213 South Jefferson Street, Suite 1011
Roanoke, Virginia 24011
T: 540-982-0800 F: 540-982-1193
WWW.CLARKNEXSEN.COM
CLARK NEXSEN LICENSE NUMBER: C-1028

CONSULTANT

CLH DESIGN, P.A.
Regency Park
400 Regency Forest Drive
Suite 120
Cary, North Carolina 27518
Phone: (919) 319-8716
Fax: (919) 319-7618
LA: C-106, PE: C-1595

SEALS

WILMINGTON NORTH CAROLINA
PROFESSIONAL ENGINEER
KATHLEEN A. LONG
05/04/18

SUBMITTAL
4 MAY 2018

CONSTRUCTION DOCUMENTS

APPROVED STORMWATER MANAGEMENT PLAN

Date: _____ Permit # _____

Signed: _____

APPROVED CONSTRUCTION PLAN

NAME DATE

PLANNING _____

TRAFFIC _____

FIRE _____

DESIGN: ZRP
DRAWN: YA, DL
REVIEW: ZRP, KAL

CN 5938
CLH 16-161