

1. REF AS FOR SCHEDULE FINISH KEY

1001 E. 30th Dr.
Arlington, VA 22204
703.526.3665
info@redesign.com

STIPULATION FOR THE CONTRACTOR TO VERIFY THE EXISTING WALL AND CEILING CONDITIONS AND VERIFY THE LOCATION OF ALL UTILITIES AND STRUCTURAL ELEMENTS PRIOR TO CONSTRUCTION. THE CONTRACTOR SHALL BE RESPONSIBLE FOR OBTAINING ALL NECESSARY PERMITS AND APPROVALS FROM THE LOCAL AUTHORITIES. THE CONTRACTOR SHALL BE RESPONSIBLE FOR OBTAINING ALL NECESSARY PERMITS AND APPROVALS FROM THE LOCAL AUTHORITIES.

CONSULTANTS

Walmart
GORDONSVILLE, VA
884 CAMP CREEK PKWY., LOUISA, VA 23083
STORE NO.: 4852-223
JOB NUMBER: 143 SGR-OR
17-027-25 | PHOTO:

ISSUE BLOCK

REV	DATE
1	04/26/18

CHECKED BY: DF
DRAWN BY: TP
PROTO CYCLE: 02/25/18
DOCUMENT DATE: 04/10/18

SECTIONS AND DETAILS

SHEET: A3

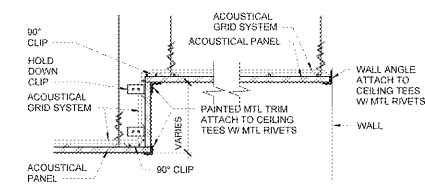

22 CEILING SECTION
1 1/2" x 1'-0"

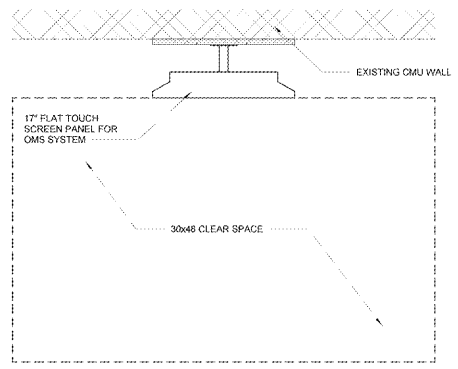

21 ORDER MANAGEMENT SYSTEM (OMS) WALL BLOCKING PLAN
1 1/2" x 1'-0"

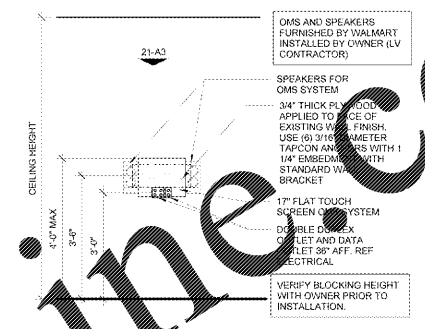

20 ORDER MANAGEMENT SYSTEM (OMS) WALL BLOCKING ELEVATION
1 1/2" x 1'-0"

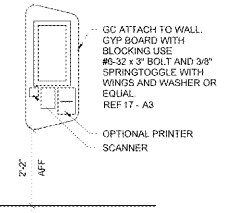

19 IN STORE MOUNTED KIOSK ELEVATION
1 1/2" x 1'-0"

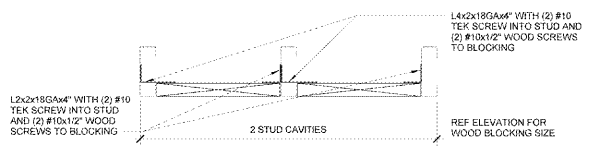

18 ORDER READY BOARD (ORB) WALL BLOCKING PLAN
1 1/2" x 1'-0"

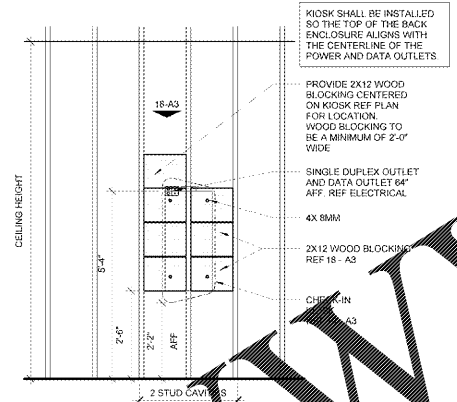

17 IN STORE PICKUP KIOSK WALL BLOCKING ELEVATION
1 1/2" x 1'-0"

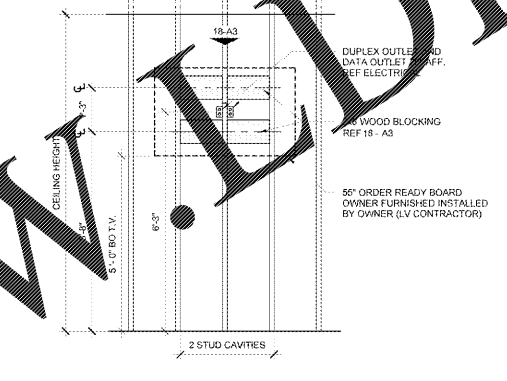

16 ORDER READY BOARD (ORB) WALL BLOCKING ELEVATION
1 1/2" x 1'-0"

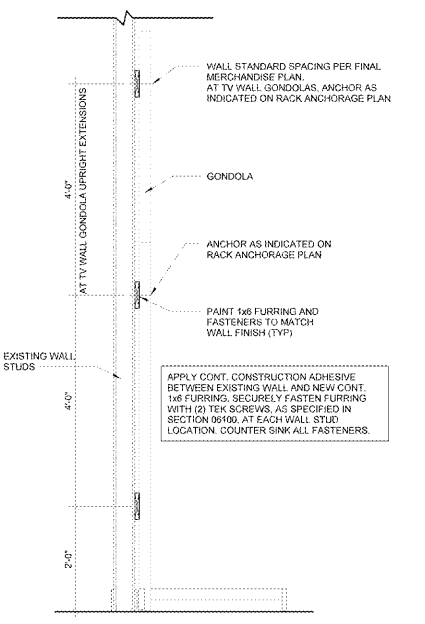

9 GONDOLA ANCHORING ON STUD WALL
3/4\"/>

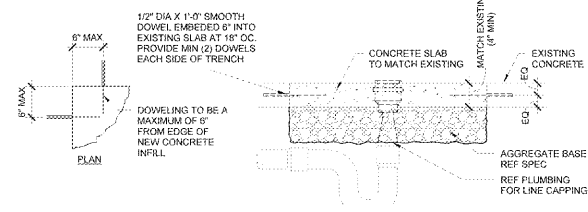

15 SLAB REPLACEMENT DETAIL
3/4\"/>

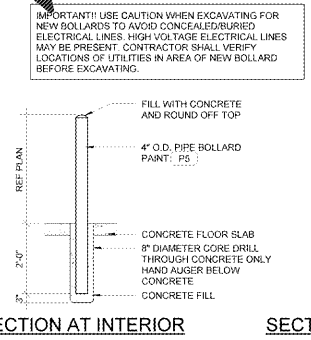

11 GARDEN CENTER/INTERIOR BOLLARD DETAIL
1 1/2\"/>

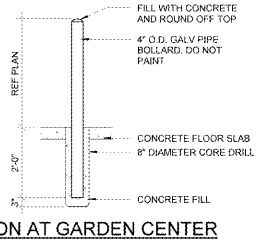

SECTION AT GARDEN CENTER

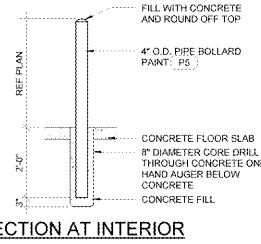

SECTION AT INTERIOR

8 NOT USED

7 NOT USED

10 NOT USED

14 NOT USED

13 NOT USED

12 NOT USED

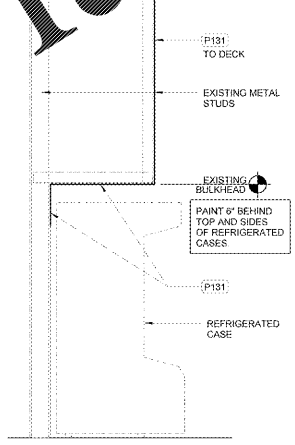

5 BULKHEAD AT CASE
1 1/2\"/>

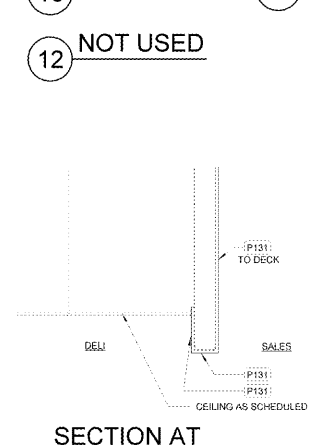

4 SECTION AT DELI BULKHEAD
1\"/>

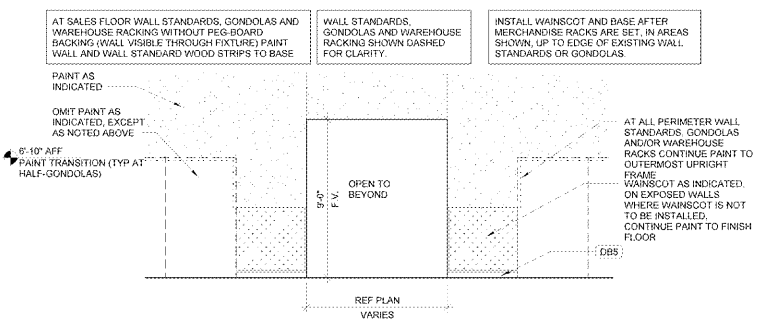

3 SALES WALL FINISHES AT PERIMETER HALF-GONDOLAS
3/4\"/>

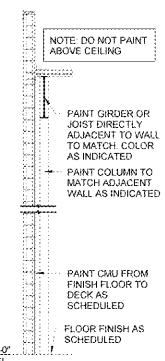

2 EXISTING EXTERIOR CMU WALL SECTION
1 1/4\"/>

1 NOT USED

Order Plans @

6 NOT USED