

**STANDARD LOCATION PLAN**  
SCALE: 1/4" = 1'-0"  
8082BASE

WWW.LDLINE.COM

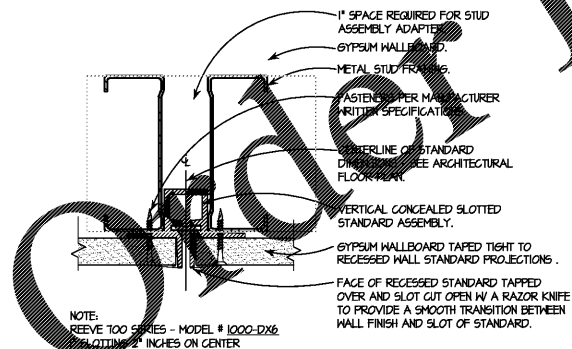

**A RECESSED STANDARD / GYP. BD. WALL DETAIL**  
SCALE: 6" = 1'-0"  
SEC-Wall-Standards

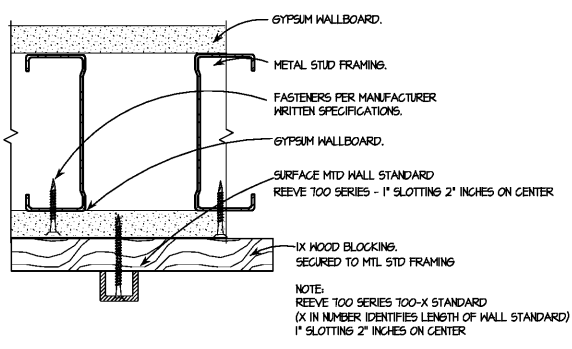

**B SURFACE STANDARD / GYP. BD. DETAIL**  
SCALE: 6" = 1'-0"  
SEC-Wall-Standards

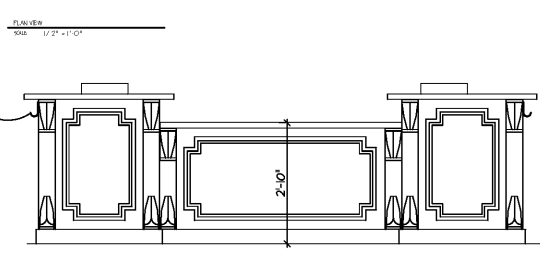
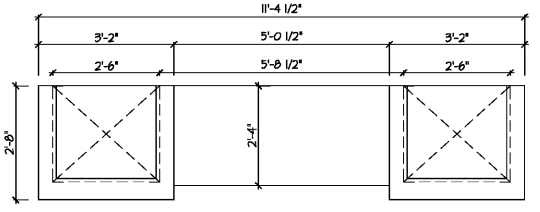

**1 CASHWRAP PLAN AND ELEVATION (ADA COMPLIANT)**  
SCALE: 1/2" = 1'-0"  
F-2.1

**WALL MOUNTED STANDARDS:**

TENANT'S GENERAL CONTRACTOR IS TO SUPPLY AND INSTALL BOTH RECESSED WALL STANDARDS AND THE FURRING MOUNTED SURFACE MOUNTED STANDARDS. TENANT'S GENERAL CONTRACTOR IS TO DOCUMENT TO CONSTRUCTION MANAGER WITHIN ONE WEEK OF CONTRACT AWARDING PURCHASE ORDERS AND DATE OF DELIVERY OF ALL COMPONENTS PROVIDED BY GENERAL CONTRACTOR.

- ◆ RECESSED STANDARD    ◇ SURFACE MTD STANDARD
- RECESS IN WALL STANDARDS ARE CAPITAL # 2080 OR REEVE STORE EQUIPMENT - 100 SERIES - 1000-DWG HALL STANDARD WHICH AND ARE 12" LONG MOUNTED AT 18" ABOVE FINISHED FLOOR.
- SURFACE MOUNTED STANDARDS ARE TO BE CAPITOL # 2000C OR REEVE STORE EQUIPMENT - 100 SERIES - 100-X HALL STANDARD (X IN NUMBER IDENTIFIES LENGTH OF HALL STANDARD) AND ARE TO BE 36", 48", OR 60" LONG PER ELEVATION AND MOUNTED AS INDICATED.

**KEN NISCH, AIA**

1110 Inkwood  
200  
Southfield, MI 48034 USA  
248 355 0890  
248 355 0895 Fax

Copyright © 2014  
KEN NISCH, AIA  
All rights reserved

Certification:  
KENNETH E. NISCH, AIA  
No. 5010  
EXPIRATION DATE: 06.30.2018

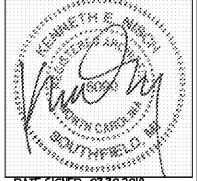

Consultants:  
**RETAIL DESIGN CONSULTANT**



JGA Inc  
29355 Northwestern Hwy  
Suite 300  
Southfield, MI 48034 USA  
248 355 0890  
248 355 0895 Fax  
www.jga.com

JGA Prj #: 1-218-082

Project Location:  
**Soft Surroundings**  
**BILTMORE VILLAGE, SPACE #160**  
10 BROOK STREET  
ASHEVILLE, TN 28803

- DRAWINGS ISSUED FOR:
- programming
  - schematic des.
  - design dev.
  - bidding
  - permit/LL review 04-06-18
  - construction

REVISIONS:

Prj. no. **8-218-030**  
Drawn IN, GV  
Checked KR, GV  
Approved KN

Do not scale this print. Use figured dimensions only.

Drawing title:  
**STANDARD LOCATION PLAN**

Sheet no.  
**F-2.1**