

**B1** VOLUME DAMPER DETAIL  
SCALE: NONE

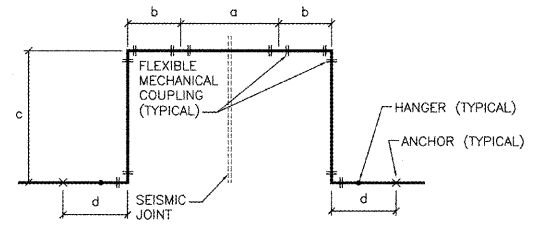

**B3** PIPING CROSSING A SEISMIC JOINT DETAIL "A"  
SCALE: NONE

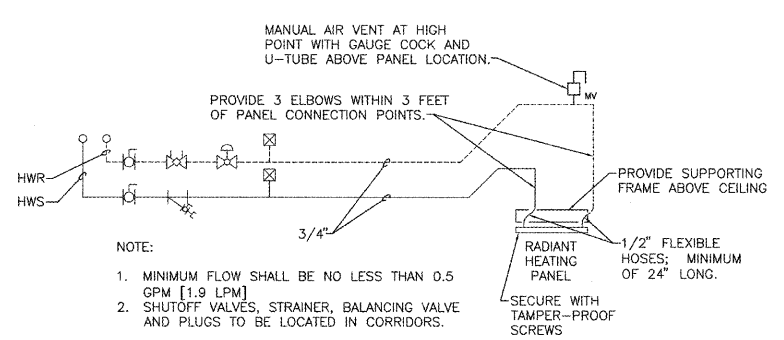

**B6** HYDRONIC RADIANT CEILING PANELS - PIPING CONNECTIONS  
SCALE: NONE

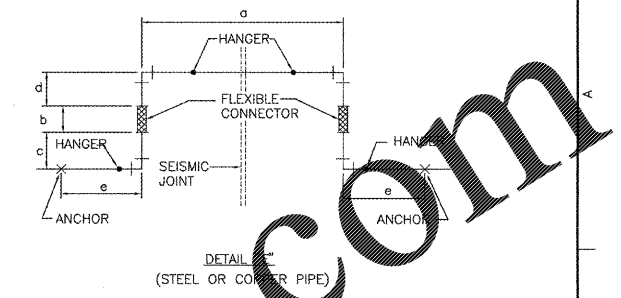

**B9** PIPING CROSSING A SEISMIC JOINT DETAIL "E"  
SCALE: NONE

SCHEDULE FOR PIPING CROSSING A SEISMIC JOINT

LOCATION	PIPE	DIMENSIONS INCHES (MM)					
		a	b	c	d	e	f
-	-	-	-	-	-	-	-

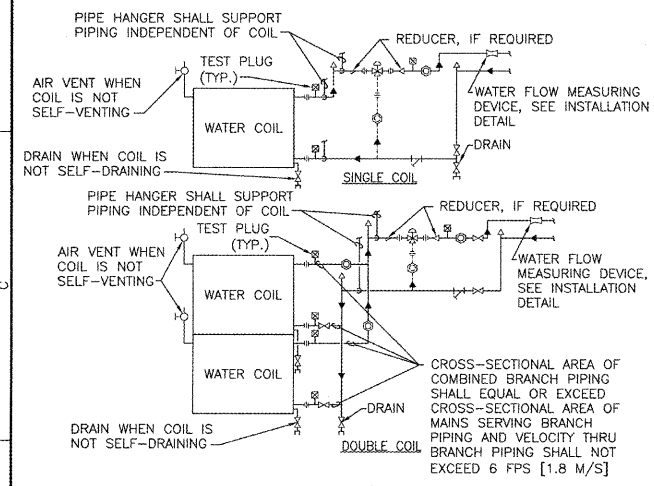

**E1** TYPICAL CONNECTIONS TO WATER COIL  
SCALE: NONE

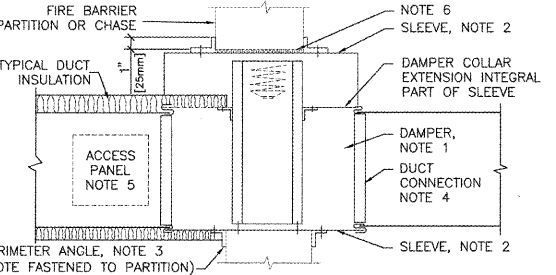

**D3** SECTION THRU TYPICAL FIRE DAMPER INSTALLATION  
SCALE: NONE

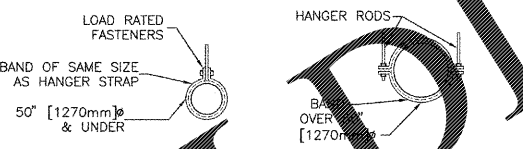

HANGER STRAPS OR RODS

MAX. DUCT IN. (mm)	#	QUANTITY/SIZE	MAX. LOAD LBS. (kg)	MAX. SPACING IN. (mm)
26 (650)	ONE	1 [25] x 22 STRAP	260 (119)	144 (3658)
30 (900)	ONE	1 [25] x 18 STRAP	420 (190)	144 (3658)
36 (900)	ONE	1 [25] x 16 GA STRAP	700 (317)	144 (3658)
42 (1060)	TWO	3/8 [10] RODS	1320 (598)	144 (3658)
48 (1210)	TWO	1/2 [13] RODS	2500 (1133)	144 (3658)

**D6** ROUND DUCT HANGERS  
SCALE: NONE

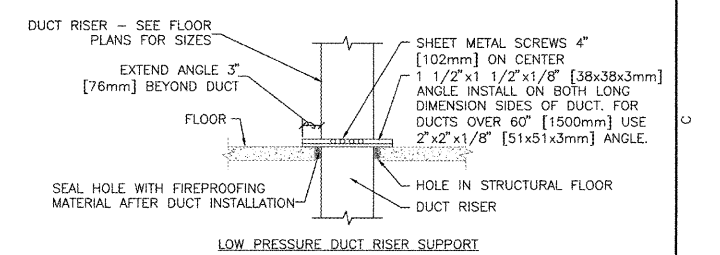

**D9** LOW, MEDIUM AND HIGH PRESSURE DUCT RISER SUPPORTS  
SCALE: NONE

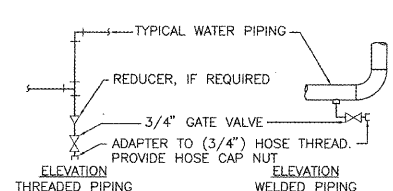

**E6** TYPICAL CHILLED AND HOT WATER PIPING DRAIN VALVE CONNECTIONS  
SCALE: NONE

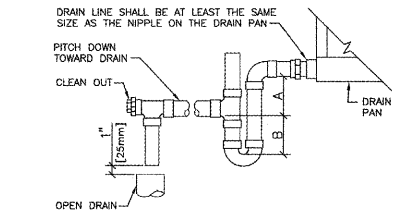

UNIT TYPE

	A	B
DRAW THRU	2" (51mm) PLUS X	X
BLOW THRU	1" (25mm) MINIMUM	2X

WHERE X = STATIC PRESSURE IN PAN

**F9** AIR HANDLING UNIT DRAIN TRAP DETAIL  
SCALE: NONE

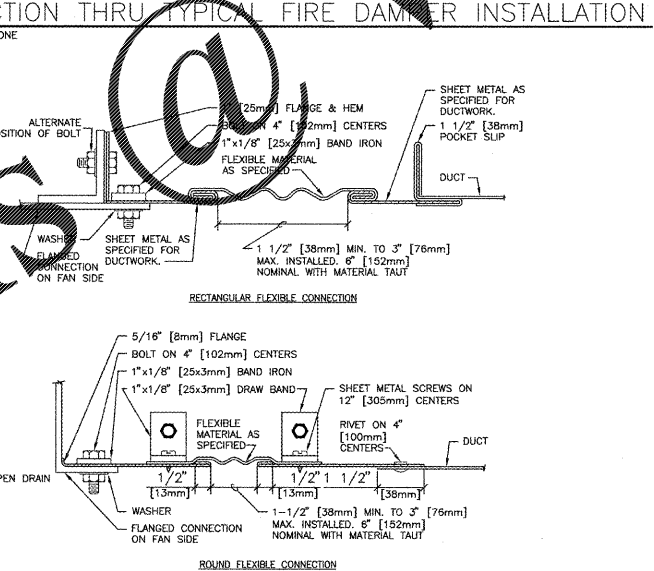

**F3** RECTANGULAR AND ROUND FLEXIBLE CONNECTION DETAILS  
SCALE: NONE

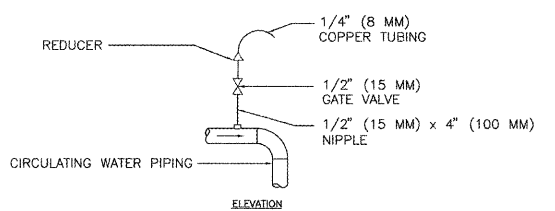

**F6** TYPICAL AIR VENT  
SCALE: NONE

REVISIONS

REVISION	DESCRIPTION

Department of Veterans Affairs  
**Charlie Norwood**  
 VA Medical Center  
 1 Freedom Way  
 Augusta, Ga. 30904

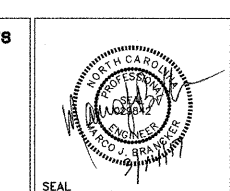

**Harrell, Saltrick & Hopper**  
 Design & Management Solutions for the Built Environment  
 8016 TOWER POINT DRIVE  
 CHARLOTTE, NC 28227  
 WWW.HSPCC.COM  
 P 704.261.1320  
 F 704.261.0833  
 COPYRIGHT © 2012 HARRELL, SALTRICK & HOPPER, PC  
 NON-PROJECT # 12025

Recommended Approvals:

1. MEDICAL CENTER DIRECTOR	6. OPERATIONS SERVICE LINE MANAGER
2. ASSISTANT DIRECTOR	7. INFECTION CONTROL MANAGER
3. CHIEF OF STAFF	8. SAFETY MANAGER
4. ASSOC. DIRECTOR	9. GENERAL ENGINEER
5. SERVICE LINE MGRS.	10. COR

Drawing Title  
**MECHANICAL DETAILS**  
 CONSTRUCTION DOCUMENTS  
 FULLY SPRINKLERED

Project Title  
**RENOVATE MENTAL HEALTH UNITS**  
 Drawn  
 Building Number  
 AutoCAD File Name  
 Checked  
 Reviewed  
 Const. Contract No.

Date  
 February 10, 2017  
 Project Number  
 509-12-104  
 DRAWING No.  
**M502**

