

three inches = one foot  
one and one half inches = one foot  
one inch = one foot  
three quarters inch = one foot  
one half inch = one foot  
one quarter inch = one foot  
three eighths inch = one foot  
one eighth inch = one foot  
one sixteenth inch = one foot

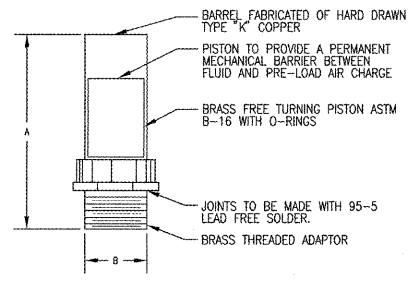

PIPE SIZE	P.D.I. SYMBOL	FIXTURE UNIT RATINGS	A SIZE	B SIZE
1/2"	A	1 - 11	5"	1 1/2"
3/4"	B	12 - 32	5"	3/4"
1"	C	33 - 60	7"	1-1/4"
1-1/4"	D	61 - 113	7"	1-1/2"
1-1/2"	E	114 - 154	9"	1-1/2"
2"	F	155 - 330	9"	2"

NOTE: SEE WATER RISER DIAGRAMS FOR LOCATIONS OF SHOCK ABSORBERS.

**B1** SHOCK ARRESTER DETAIL  
SCALE: NONE

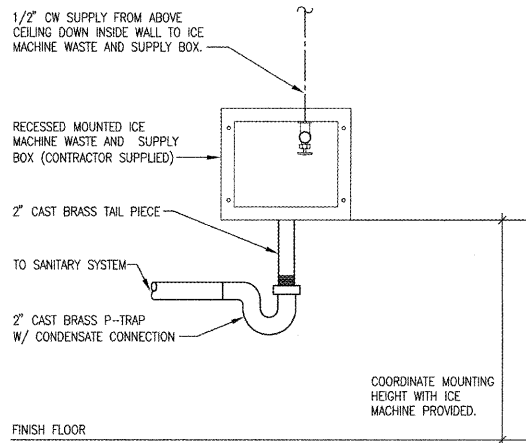

**B4** ICE MAKER SUPPLY BOX DETAIL  
SCALE: NONE

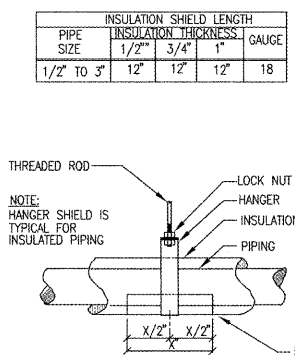

**B6** INSULATION SHIELD DETAIL  
SCALE: NONE

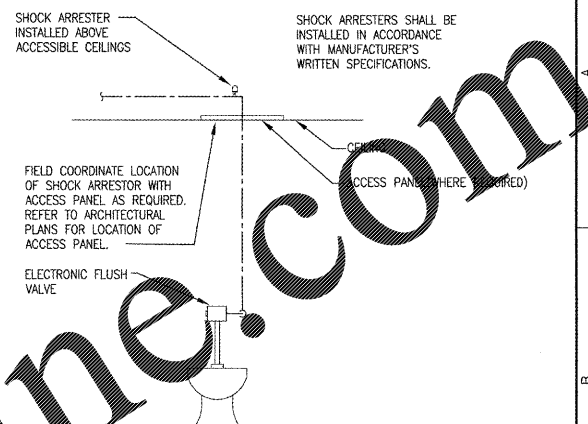

**B9** WATER HAMMER ARRESTER  
SCALE: NONE

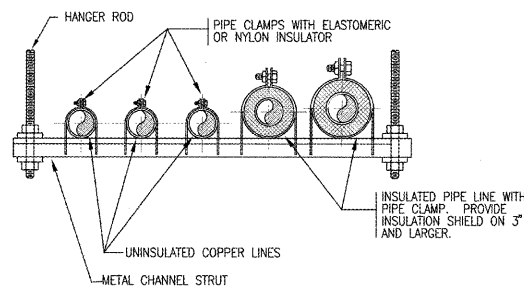

**C1** TRAPEZE HANGER DETAIL  
SCALE: NONE

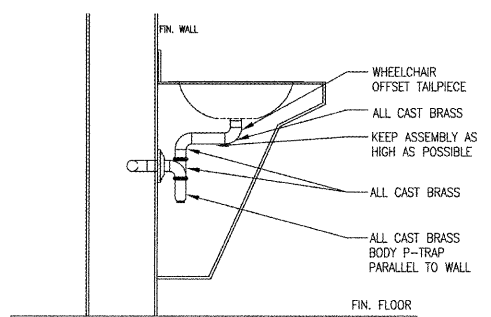

**C4** LAVATORY/SINK OFFSET DETAIL  
SCALE: NONE

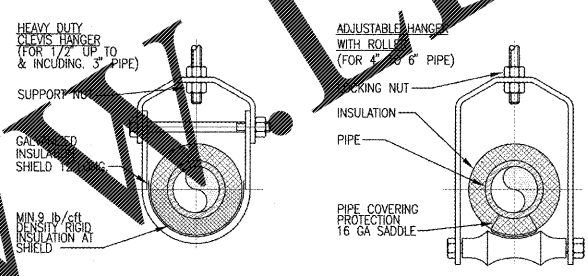

**C6** PIPE HANGER SUPPORT DETAIL  
SCALE: NONE

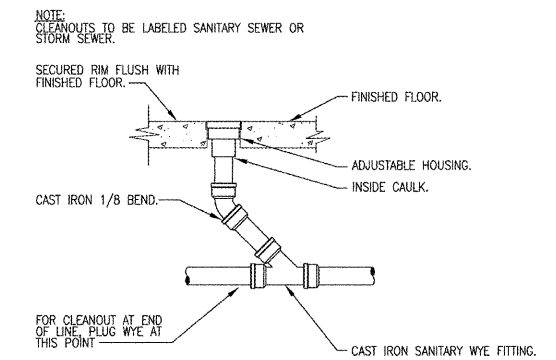

**C9** FLOOR CLEANOUT DETAIL  
SCALE: NONE

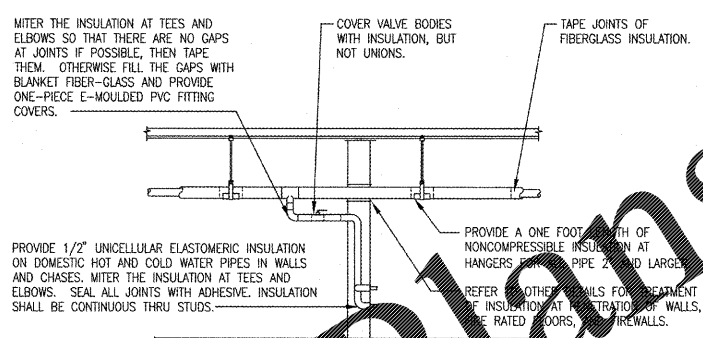

**F1** PIPE INSULATION  
SCALE: NONE

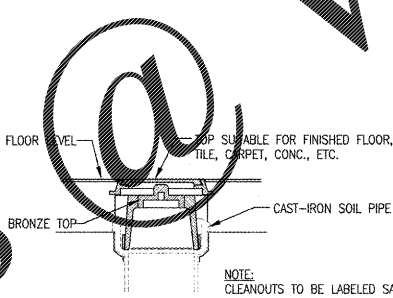

**E4** CLEAN OUT DETAIL  
SCALE: NONE

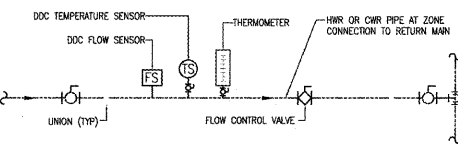

**E6** TYPICAL DDC MONITORING AT HW RECIRCULATION & CW CIRCULATION ZONES  
SCALE: NONE

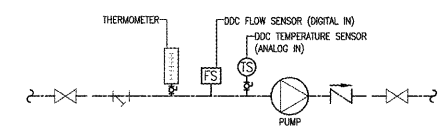

**F1** TYPICAL DDC MONITORING AT HW RECIRCULATION & CW CIRCULATION PUMPS  
SCALE: NONE

# Order Plans

REVISION	DESCRIPTION

Department of Veterans Affairs  
**Charlie Norwood**  
VA Medical Center  
1 Freedom Way  
Augusta, Ga. 30904

Seal of the Department of Veterans Affairs

**Harrell, Saltrick & Hopper**  
Design & Management Solutions for the Built Environment  
5010 TOWER POINT DRIVE  
CHARLOTTE, NC 28227  
P 704.814.1320  
F 704.351.0833  
WWW.HSHPC.COM  
COPYRIGHT © 2012 HARRELL, SALTRICK & HOPPER, PC  
HVAC PROJECT # 12025

Recommended Approvals: (102mm)		Drawing Title <b>PLUMBING DETAILS</b>	Project Title <b>RENOVATE MENTAL HEALTH UNITS</b>	Date February 10, 2017
1. MEDICAL CENTER DIRECTOR	6. OPERATIONS SERVICE LINE MANAGER	100% CONSTRUCTION DOCUMENTS	Drawn LDR	Building Number 509-12-104
2. ASSISTANT DIRECTOR	7. INFECTION CONTROL MANAGER			
3. CHIEF OF STAFF	8. SAFETY MANAGER	FULLY SPRINKLERED	Checked Reviewed	AutoCAD File Name 
4. ASSOC. DIRECTOR	9. GENERAL ENGINEER			
5. SERVICE LINE MGRS.	10. COR	Const. Contract No. 		DRAWING No. <b>PL501</b>

**Veterans Affairs**