

Order Plans @

WWW.LDILine.com

STOREFRONT AND WINDOW SPECIFICATIONS

STOREFRONTS: KAWNEER (OR MATCH EXISTING STOREFRONT) THERMALLY BROKEN 2" X 4-1/2" SYSTEM (OR EQUAL).

STOREFRONTS FOR AREAS WITH HIGH WIND CONDITIONS: YKK 45 TL THERMALLY BROKEN 2" X 4-1/2" SYSTEM (OR EQUAL).

OPERABLE PATIO WINDOWS: SOVEREIGN MOTORIZED OVERHEAD DOOR, 4-PANEL STYLE WITH 3 EQUAL VERTICAL PANE. ARCHITECT TO REVIEW FINISH OPTIONS.

1. THERMAL MULTI PLANE, CENTER SET, 2" X 4 1/2"
2. FINISH: DARK BRONZE ANODIZED
3. DOORS: NARROW STYLE DOORS WITH 1" GLAZING
4. GLAZING: ALL EXTERIOR GLAZING TO BE 1" INSULATED PANELS AND MATCH TO EXISTING BY LANDLORD. 1/4" CLEAR (NORTH AMERICAN), SUNGUARD SN 68 (NORTH AMERICAN) ON 2ND SURFACE, 1/2" AIR SPACE, 1/4" CLEAR (NORTH AMERICAN) INSIDE PANEL.
5. INTERIOR GLAZING TO BE 1/4" CLEAR, SINGLE PANE UNLESS NOTED OTHERWISE.
6. PROVIDE TEMPERED GLAZING WHERE INDICATED AND AS REQUIRED. SAFETY GLAZING TO BE PROVIDED AT ALL LOCATIONS SPECIFIED IN 2012 IBC SECTION 2403.
7. STOREFRONT CASEMENT WINDOW FINISHES AS THERMAL KAWNEER GLASSVENT, OR EQUAL.

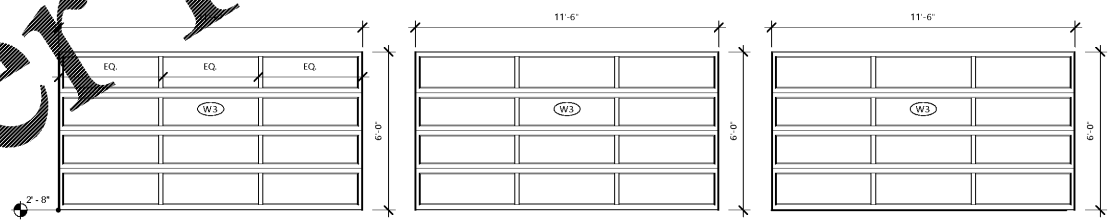

3 PATIO OPERABLE WINDOWS
36'-1-0"

NOTE: VERIFY ROUGH OPENING DIMENSIONS/REQUIREMENTS WITH MANUFACTURER

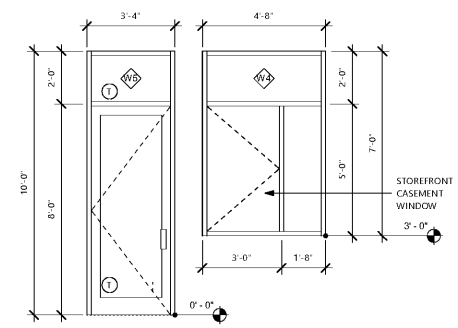

2 STOREFRONT ELEVATION 2
36'-1-0"

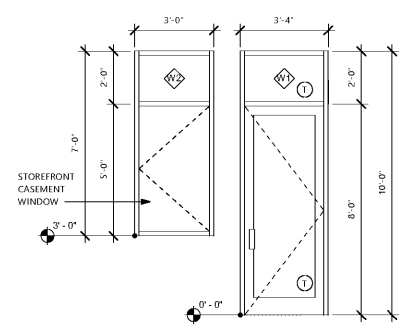

1 STOREFRONT ELEVATION 1
36'-1-0"

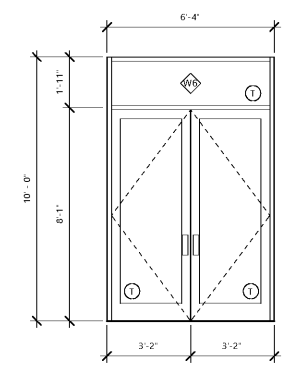

4 INTERIOR VESTIBULE STOREFRONT
36'-1-0"

Firebirds Peachtree Corners

5215 Town Center Drive, Suite 600
Peachtree Corners, GA 30091



starr design
branded environments

Starr Design, PLLC
1435 West Morehead St, Suite 340
Charlotte, NC 28208
704.377.5200 704.377.5201
www.stardesignteam.com

CONSTRUCTION DOCUMENTS
05/10/2018

No. Description Date

Steven A. Starr, AIA
Lic. # RA013717
Signature Date: 05/10/2018
Date of expiration: 6/30/2019



STOREFRONT ELEVATIONS

A8.02

16FB008 | © Starr Design, PLLC