

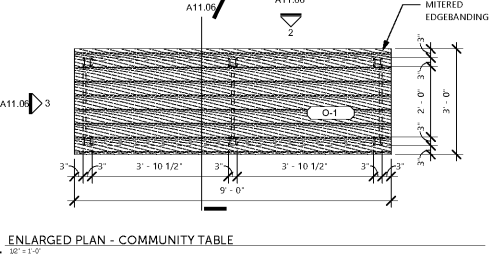

NOTE: VERIFY ALL DIMENSIONS IN FIELD. BOOTH BUILT BY SOFT TOUCH FURNITURE. BOOTH TO FIT INTO RECESSED AREA - REF. A11.01a

NOTE: VERIFY ALL DIMENSIONS IN THE FIELD. BOOTH BUILT BY SOFT TOUCH FURNITURE. BOOTH TO FIT INTO MILLWORK, REFERENCE A11.05

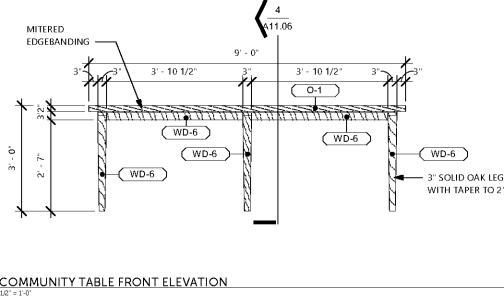
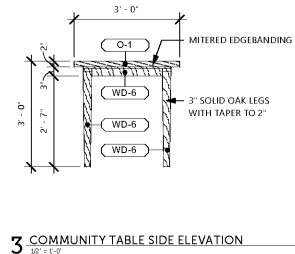
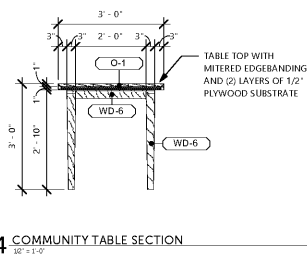
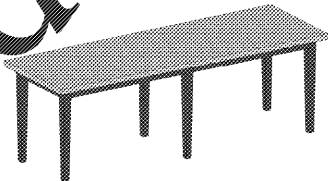
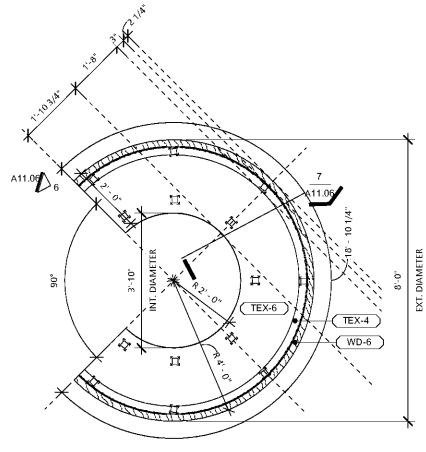
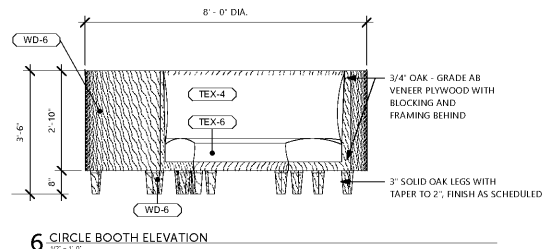
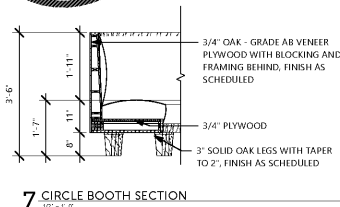
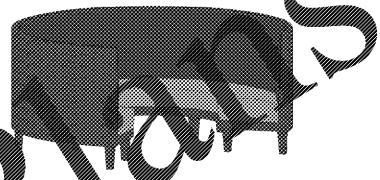
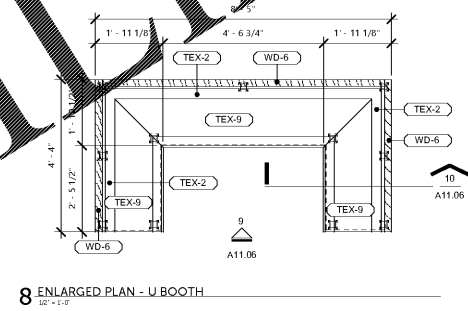
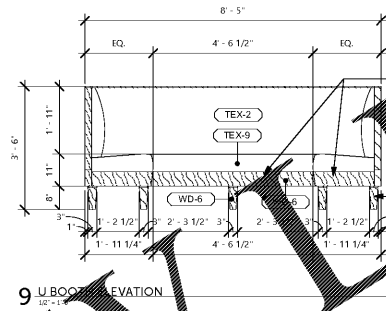
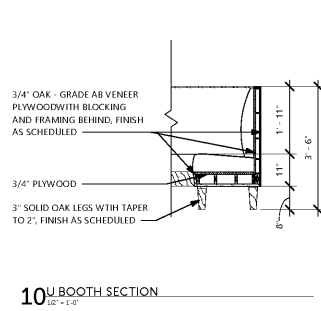
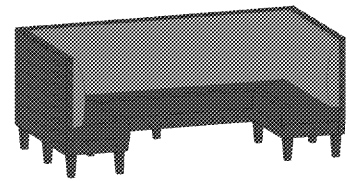

Order Plans @ WWW.LDOnline.com