

1 INTERIOR ELEVATION 4 AT DINING AREA

1/4" = 1'-0"

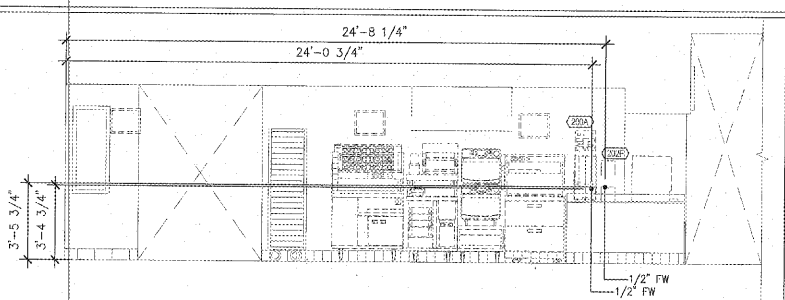

2 INTERIOR ELEVATION 6 AT KITCHEN AREA

1/4" = 1'-0"

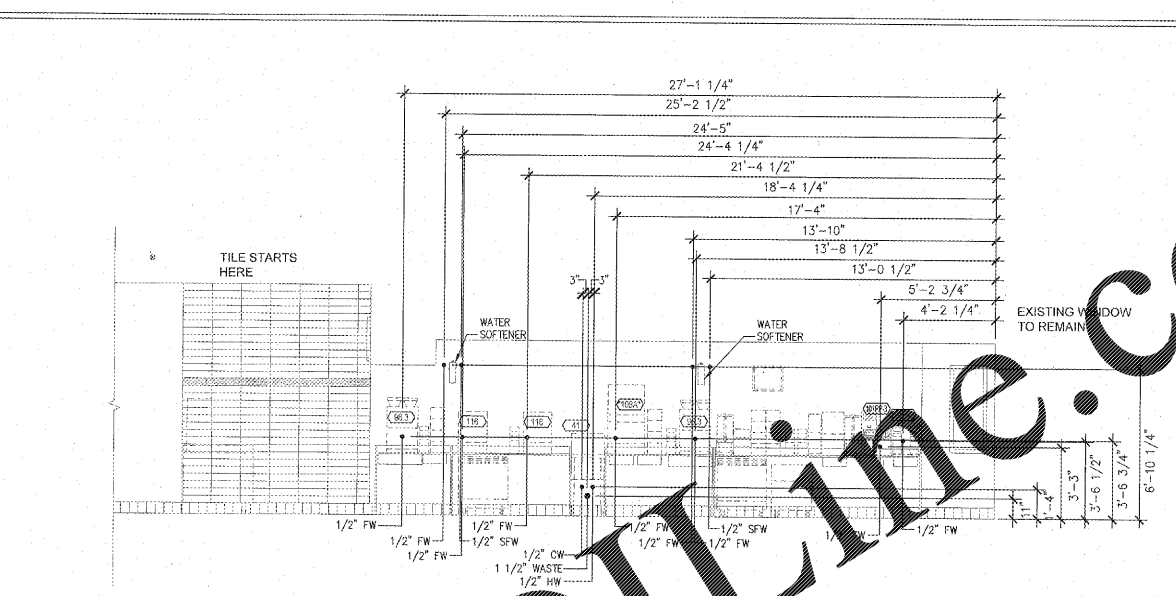

3 INTERIOR ELEVATION 7 AT KITCHEN AREA

1/4" = 1'-0"

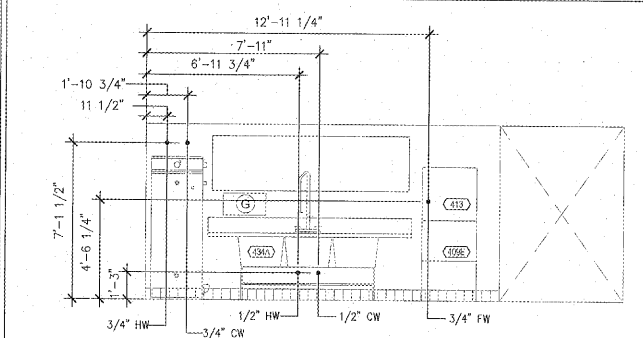

4 INTERIOR ELEVATION 9 AT DRIVE THRU

1/4" = 1'-0"

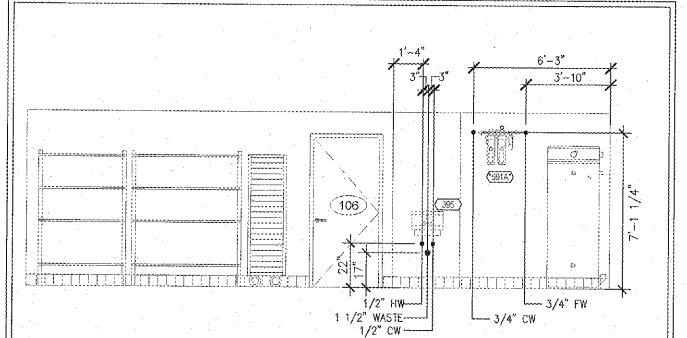

5 INTERIOR ELEVATION 10 AT PREP

1/4" = 1'-0"

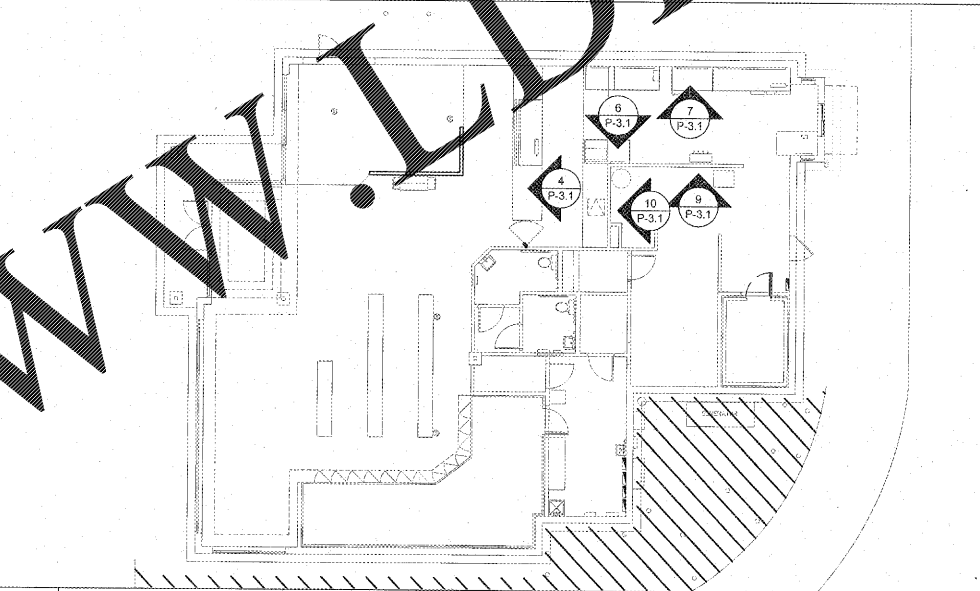

6 KEY PLAN

N.T.S.

Order Plans @ www.LDOnline.com

THESE PLANS ARE CONFIDENTIAL PROPERTY OF DUNKIN' BRANDS, INC. UNLESS RESTRICTED ACCESS.

dunkin' Brands

PROJECT NO.: 17229

NRD national restaurant designers
ARCHITECTS & ENGINEERS

3005 Carrington Mill Blvd., Morrisville, NC 27560
Tel: 919 544 7201 Fax: 919 544 9396
A Division of LMHT Associates

REGISTERED PROFESSIONAL ENGINEER
COMMONWEALTH OF VIRGINIA
LICENSED PROFESSIONAL ENGINEER
NO. 10000

NO	DESCRIPTION	DATE	SCALE	DRAWN	CKD	APPD

3-18-18

DD FRESH BREW 1.0 DUNKIN DESIGN GUIDELINES	PC NUMBER
PLUMBING INTERIOR ELEVATION PLAN	

P-3.1

NOTE: DRAWINGS ARE NOT TO SCALE IF SHEET IS PLOTTED ON 11" x 17"