

1 FLOOR PLAN

1/4" = 1'-0" NOTE:

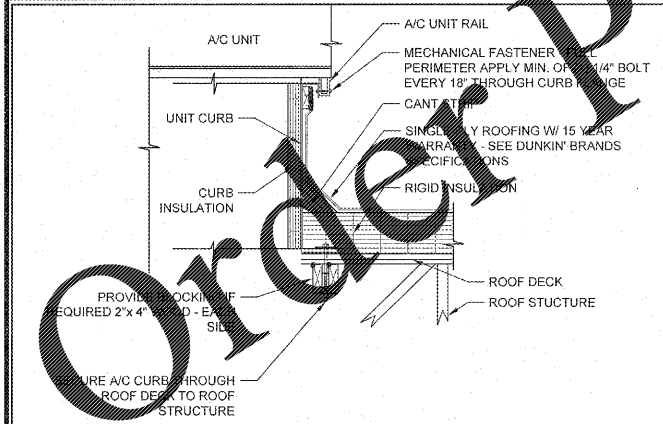

2 DETAIL AT CURB

1-1/2" = 1'-0" NOTE:

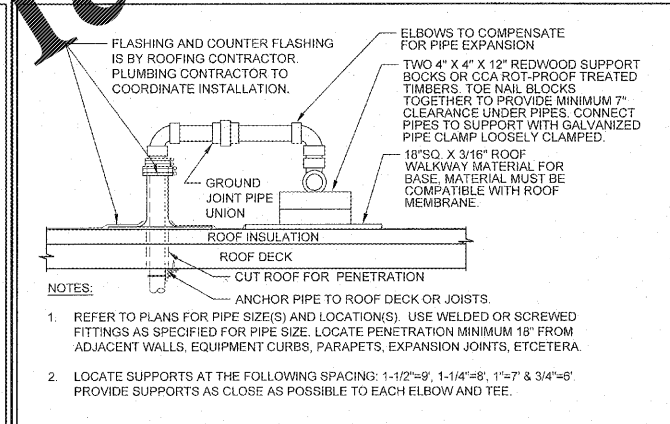

3 ROOF PENETRATION

N.T.S. NOTE:

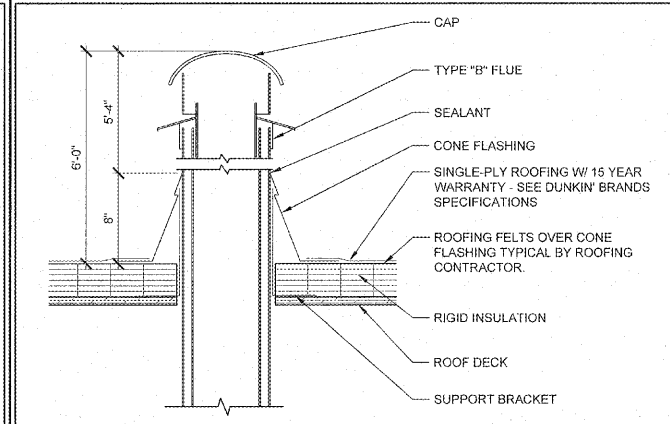

4 EXHAUST PIPE PENETRATION

1-1/2" = 1'-0" NOTE:

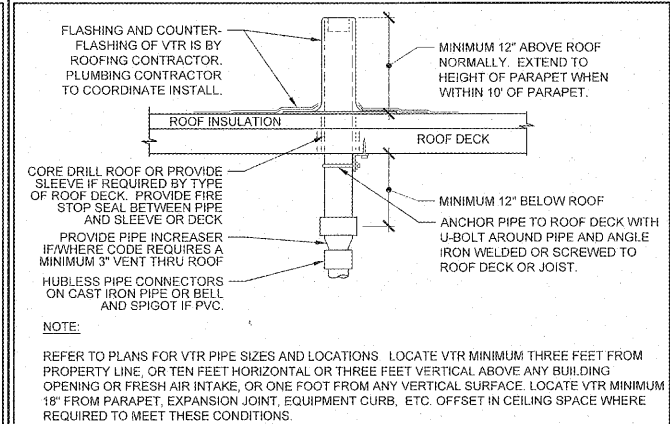

5 VENT THRU ROOF

1-1/2" = 1'-0" NOTE:

NOTE: DRAWINGS ARE NOT TO SCALE IF SHEET IS PLOTTED ON 11" x 17"

THESE PLANS ARE CONFIDENTIAL PROPERTY OF DUNKIN' BRANDS, INC. UNDER RESTRICTED ACCESS.

**Dunkin' Brands**

PROJECT NO.: 17229

**NRD** National Restaurant Designers  
ARCHITECTS & ENGINEERS

3005 Carrington Mill Blvd., Morrisville, NC 27560  
ph: 919 544 7251 fax: 919 544 9399

A Division of LMHT Associates

CONTRACTOR OF VIRGINIA  
Glen Russell Lehmann  
Lic. No. 089911

NO	DESCRIPTION	DATE	DATE	DATE
1	OWNER COMMENTS (RESTROOM CHANGE)	5/2/18		

SET REVISIONS	DATE	DATE	DATE

NO	DESCRIPTION	DATE	DATE	DATE

DATE	SCALE	DRAWN	CKD	APPD
3-18-18		AY	TD	

DD FRESH BREW 1.0  
908 MARKET DRIVE, EMPORIA, VA

ROOF PLAN AND DETAILS

PC# 358084

A-3.0