

ELECTRICAL PACKAGES - Job#3227534

NO.	TAG	PACKAGE #	LOCATION	SWITCHES		OPTION	FANS CONTROLLED					
				LOCATION	QUANTITY		FAN TAG	TYPE	H.P.	VOLT	FLA	
1	DCV1	DCV-3111	Utility Cabinet Right	04 - Utility Cabinet Right	1 Light	Smart Controls DCV	EF1	Exhaust	3	0.750	208	2.6
				Hood # 2	1 Fan		EF2	Exhaust	3	0.750	208	2.6
							EF3	Exhaust	3	0.750	208	2.6
							MAU1	Supply	3	5.000	208	15.0

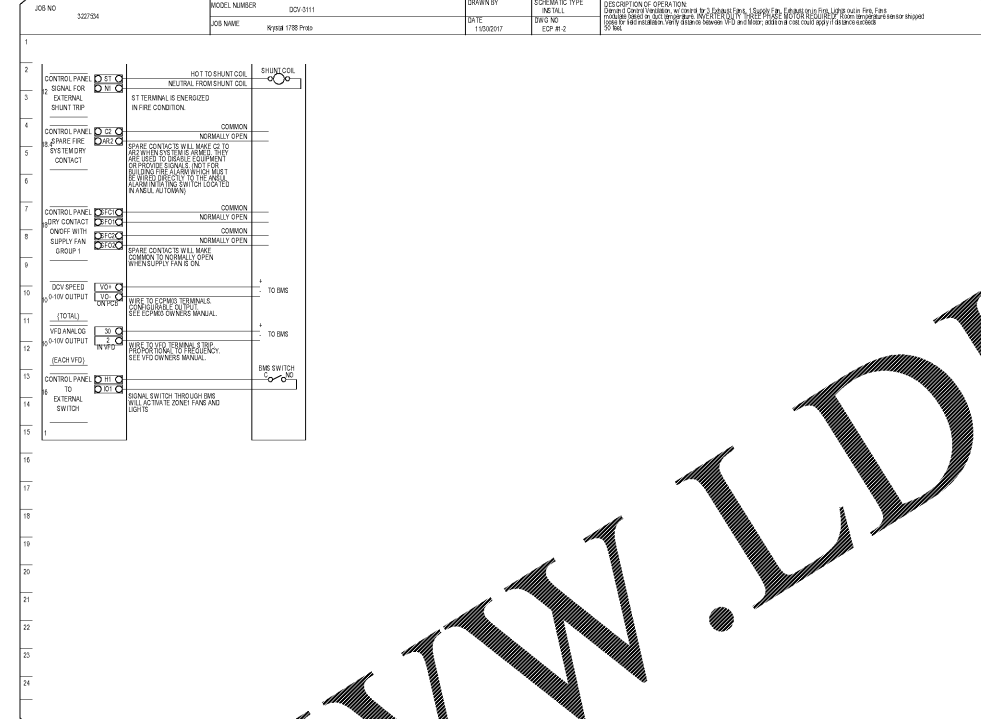

Field Connection to Router or Ethernet Switch

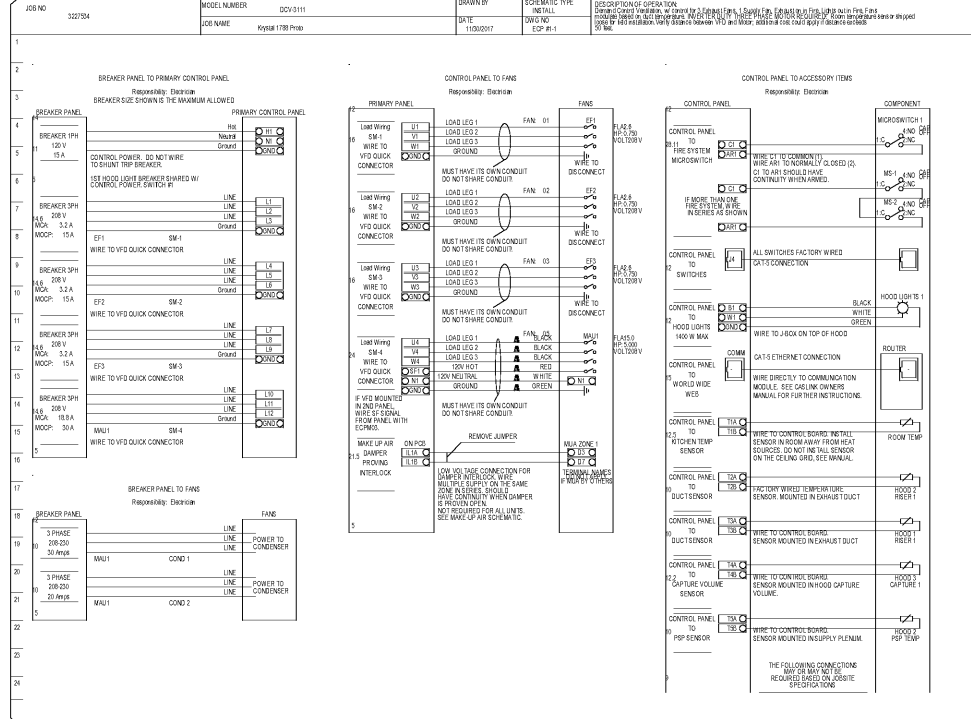
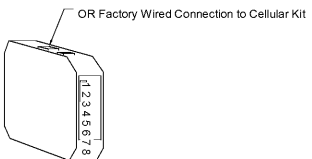

CASlink Monitor and Control
 - Hood control panel to support communications to cloud-based Building Management System.
 - Hood Control Panel to allow cloud-based Building Management System to monitor real time parameters outlined as MONITOR in the points list.
 - Hood Control Panel to allow cloud-based Building Management System to control parameters outlined as CONTROL in the points list.
 - Hood control panel to allow control changes to system settings such as VFD Frequencies, ECM speeds, temperature set points, fan air flow settings, MONITORING AND CONTROL POINTS LIST.

DCV Packages	Function	SC Packages	Function
Room Temperature	MONITOR	Room Temperature(s)	MONITOR
Duct Temperature(s)	MONITOR	Duct Temperature(s)	MONITOR
MUA Discharge Temperature	MONITOR	MUA Discharge Temperature	MONITOR
Kitchen RTU Discharge Temperature	MONITOR	Kitchen RTU Discharge Temperature	MONITOR
Fan Speed	MONITOR	Control Panel Faults	MONITOR
Fan Amperage	MONITOR	Fan Faults	MONITOR
Fan Power	MONITOR	Fan Status	MONITOR
VFD Faults	MONITOR	PCU Faults	MONITOR
Controller Faults	MONITOR	PCU Filter Clog Percentages	MONITOR
Fan Faults	MONITOR	Fire Condition	MONITOR
Fan Status	MONITOR	CORE Fire System	MONITOR
PCU Faults	MONITOR	Building Pressures	MONITOR & CONTROL
PCU Filter Clog Percentages	MONITOR	Fans Button(s)	MONITOR & CONTROL
Fire Condition	MONITOR	Lights Button(s)	MONITOR & CONTROL
CORE Fire System	MONITOR	Wash Button	MONITOR & CONTROL
Building Pressures	MONITOR		
Fans Button	MONITOR & CONTROL		
Lights Button	MONITOR & CONTROL		
Wash Button	MONITOR & CONTROL		

Demand Control Ventilation Hood Control Specifications

- Controls shall be listed by UL (UL 508) and shall comply with demand ventilation system turndown requirements as defined in IECC 403.2.2015.
- The control enclosure shall be NEMA 1 rated and installed inside of the exhaust hood utility cabinet. The control enclosure material shall be constructed of stainless steel or painted steel.
- Temperature probe(s) located in the exhaust duct riser(s) shall be constructed of stainless steel.
- A digital controller shall be provided to activate the hood exhaust fans dynamically based on a setpoint differential between the ambient and duct temperature sensors. This function shall meet the requirements of IMC 5.7.1.1.
- A digital controller shall provide adjustable hysteresis settings to prevent cycling of the fans after the cooking appliances have been turned off and/or the heat in the exhaust system is reduced.
- A digital controller shall provide an adjustable minimum fan run-time setting to prevent fan cycling.
- Variable Frequency Drives (VFDs) shall be provided for fans as required. The digital controller shall modulate the VFDs between a minimum setpoint and a maximum setpoint on demand. The duct temperature sensor input(s) to the digital controller shall be used to calculate the speed reference signal.
- The VFD speed range of operation shall be from 0% to 100% for the system, with the actual minimum speed set as required to meet minimum ventilation requirements.
- An internal algorithm to the digital controller shall modulate supply fan VFD speed proportional to all exhaust fans that are located in the same fan group as the supply fan.
- The system shall operate in PREP MODE during light cooking load or COOL DOWN MODE when sufficient heat remains underneath the hood system after cooking operations have completed. Operation during either of these periods will disable the supply fans and provide an exhaust fan speed that is equal to the minimum ventilation requirement.
- A digital controller shall disable the supply fan(s), activate the exhaust fan(s), activate the appliance shunt trip, and disable an electric gas valve automatically when fire condition is detected on a covered hood.
- A digital controller shall allow for external BMS fan control via Dry Contact (external control shall not override fan operation logic as required by code).
- An LCD interface shall be provided with the following features:
 - On/Off push button fan & light switch activation
 - Integrated gas valve reset for electronic gas valves (no reset relay required)
 - VFD Fault display with audible & visual alarm notification
 - Duct temperature sensor failure detection with audible & visual alarm notification
 - Mis-wired duct temperature sensor detection with audible & visual alarm notification
 - A single low voltage Cat-5 RJ45 wiring connection
 - An energy savings indicator that utilizes measured kWh from the VFDs

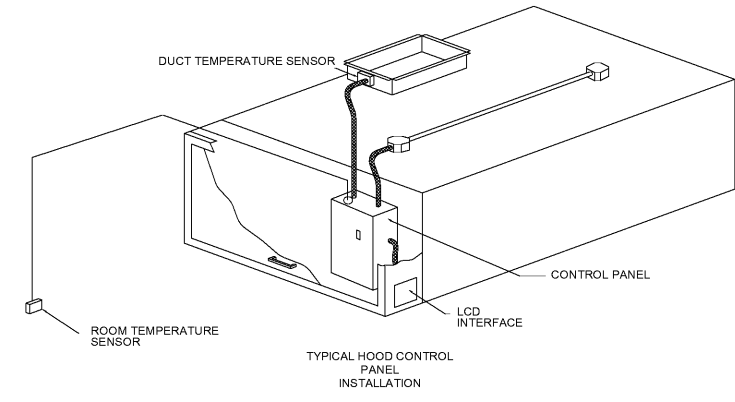

Sequence of Operations:
 The hood control panel is capable of operating in one or more of the following states at any given time:

- Automatic:** The system operates based on the differential between room temperature and the temperature at the hood cavity or exhaust duct collar. Fans activate at a configurable temperature differential threshold. Depending on the job configuration each fan zone can be configured as static or dynamic. These terms refer to whether a variable motor (such as EC Motors or VFD driven motors) modulate with temperature. If the panel is equipped with variable speed fans and the zone is defined as "dynamic", these will modulate within a user-defined range based on the temperature differential. Panels equipped with variable speed fans and a fan zone defined as "static", fans will run at a set speed calculated for the drive. Demand control ventilation systems are capable of modulating exhaust and make up air fan speeds per the requirements outlined in IECC 403.2.8.
- Manual:** The system operates based on human input from an HMI.
- Schedule:** A weekly schedule can be set to run fans for a specified period throughout the day. There are three occupied times per day to allow for the user to set up a time that is suitable to their needs. Any time that is within the defined occupied time, the system will run at modulation mode and follow the fan procedure algorithm based on temperature during this time. During unoccupied time, the system will have an extra offset to prevent unintended activation of the system during a time where the system is not being occupied.
- Other:** The system operates based on the input from an external source (DDC, BMS or hard-wired interlock).

RAD
 Ragona Architecture & Design, PLLC
 1447 Highway 138, Suite C
 Conyers, GA 30012
 770.236.7729
 rad@rad-arch.com

WAVE ENGINEERING
 122 W. BLAND ST. SUITE C
 CONYERS, GA 30012
 770.236.7729
 info@wave-engineering.com
 WAVE PROJECT # 19072

#ATL034
CONYERS, GA

Krystal
 GEORGIA REGISTERED PROFESSIONAL ENGINEERS
 3/22/18

ISSUED FOR CONSTRUCTION
 1447 Highway 138
 Conyers, Georgia 30012
 Rockdale County, Georgia

Revisions		
#	Date	Description

Project Number: 19028
 Issued for: CONSTRUCTION
 Issue Date: 03/22/18

DRAWING TITLE
HOOD DRAWINGS

SHEET NUMBER
M305