

GRAVITY SEWER LINE TESTING
LOW PRESSURE AIR TEST TABLE

| PIPE LENGTH (IN FEET) | PIPE DIAMETER (IN INCHES) | | | | | | | | | |
|-----------------------|---------------------------|------|------|------|------|------|-------|-------|-------|-------|
| | 4" | 6" | 8" | 10" | 12" | 15" | 18" | 21" | 24" | |
| 25 | 0.04 | 0.10 | 0.15 | 0.28 | 0.40 | 1.02 | 1.77 | 2.91 | 2.38 | |
| 50 | 0.09 | 0.20 | 0.35 | 0.55 | 1.19 | 2.94 | 2.98 | 4.93 | 5.17 | |
| 75 | 0.13 | 0.29 | 0.52 | 1.27 | 1.59 | 3.06 | 4.27 | 5.94 | 7.55 | |
| 100 | 0.18 | 0.40 | 1.10 | 1.50 | 2.38 | 4.08 | 5.66 | 8.05 | 10.34 | |
| 125 | 0.22 | 0.50 | 1.28 | 2.18 | 3.18 | 5.09 | 7.26 | 9.50 | 11.20 | |
| 150 | 0.26 | 0.59 | 1.46 | 2.45 | 3.58 | 6.11 | 8.30 | | | |
| 175 | 0.32 | 1.02 | 2.02 | 3.13 | 4.27 | 7.05 | | | | |
| 200 | 0.35 | 1.19 | 2.21 | 3.40 | 5.17 | | | | | 12.06 |
| 225 | 0.40 | 1.29 | 2.39 | 4.08 | 5.40 | | | 10.26 | 13.26 | |
| 250 | 0.44 | 1.39 | 2.56 | 4.35 | | | 8.31 | 11.26 | 15.07 | |
| 275 | 0.48 | 1.49 | 3.14 | 4.63 | | | 9.21 | 12.44 | 16.38 | |
| 300 | 0.53 | 1.59 | 3.31 | 4.48 | | | 10.12 | 13.53 | 18.09 | |
| 350 | 1.02 | 2.19 | 3.47 | | | 9.15 | 11.54 | 16.12 | 21.10 | |
| 400 | 1.28 | 2.38 | | | 6.03 | 9.27 | 13.36 | 18.51 | 24.15 | |

HERNANDO COUNTY UTILITIES DEPARTMENT
21030 CORTEZ BOULEVARD
BROOKSVILLE, FLORIDA 34601
OFFICE: (352) 754-4037 FAX: (352) 754-4485

GRAVITY SEWER LINE TESTING
LOW PRESSURE AIR TEST TABLE
DETAIL: 27
PAGE D-28
DATE: JANUARY 2013

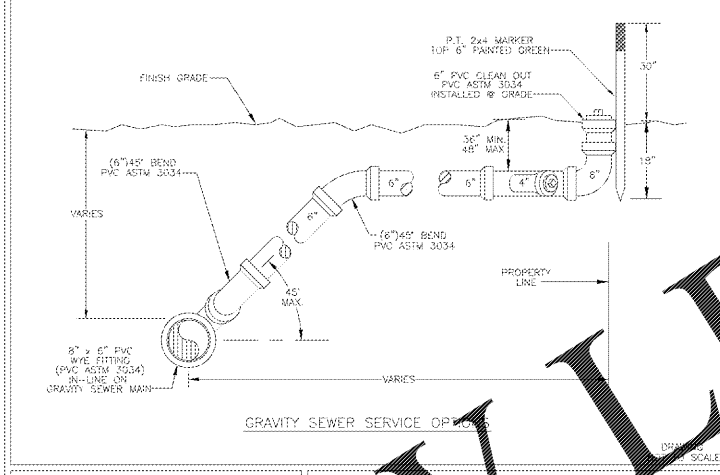
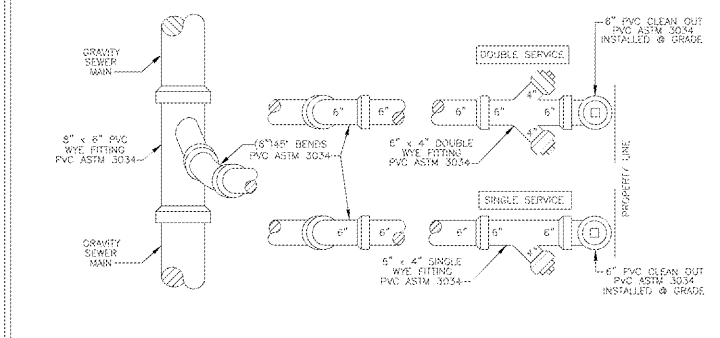

HERNANDO COUNTY UTILITIES DEPARTMENT
21030 CORTEZ BOULEVARD
BROOKSVILLE, FLORIDA 34601
OFFICE: (352) 754-4037 FAX: (352) 754-4485

GRAVITY SEWER SERVICE PIPE FITTINGS DETAIL
DATE: JANUARY 2013
PAGE D-28

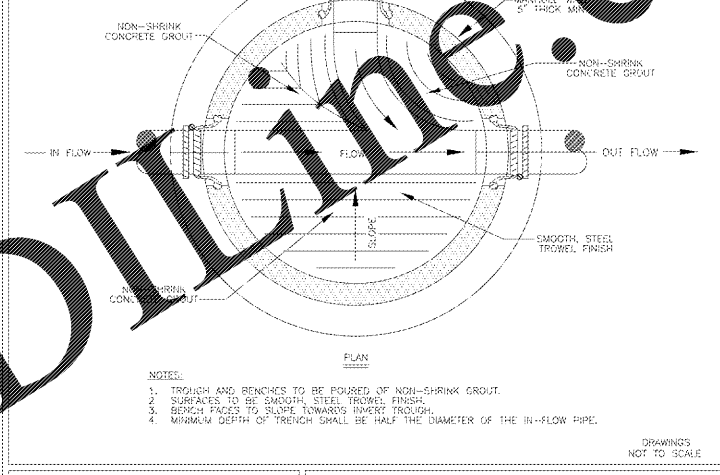
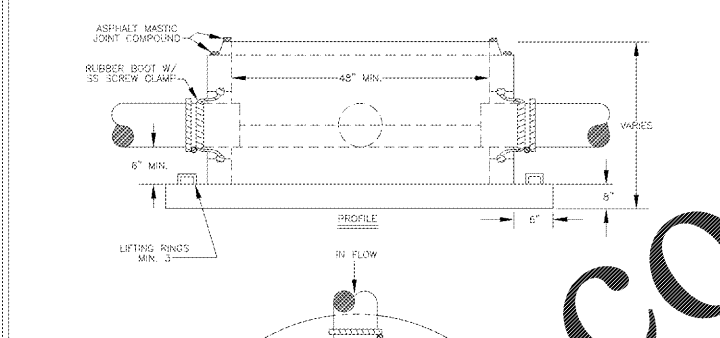

HERNANDO COUNTY UTILITIES DEPARTMENT
21030 CORTEZ BOULEVARD
BROOKSVILLE, FLORIDA 34601
OFFICE: (352) 754-4037 FAX: (352) 754-4485

MANHOLE BASE & INVERT TROUGH DETAIL
DETAIL: 31
PAGE D-32
DATE: JANUARY 2013

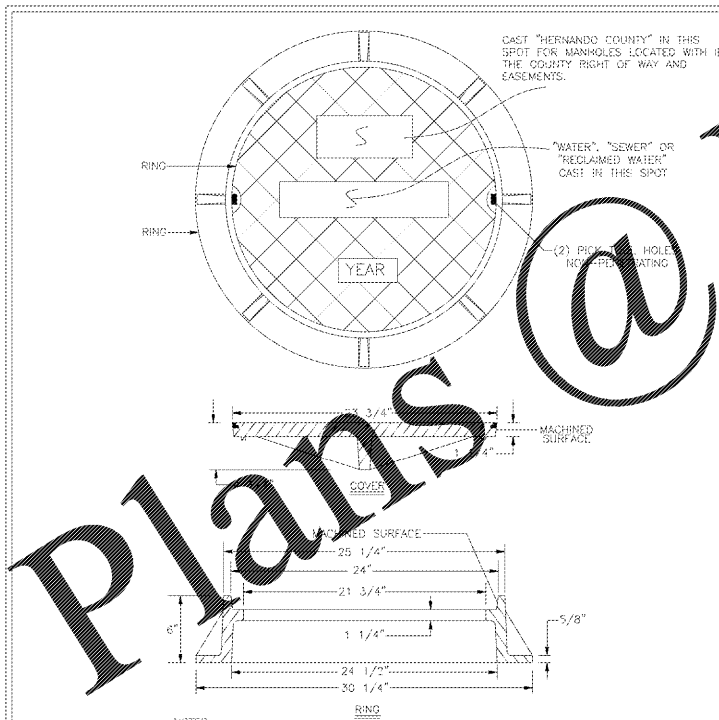

HERNANDO COUNTY UTILITIES DEPARTMENT
21030 CORTEZ BOULEVARD
BROOKSVILLE, FLORIDA 34601
OFFICE: (352) 754-4037 FAX: (352) 754-4485

MANHOLE RING & COVER DETAIL
DETAIL: 33
PAGE D-34
DATE: JANUARY 2013

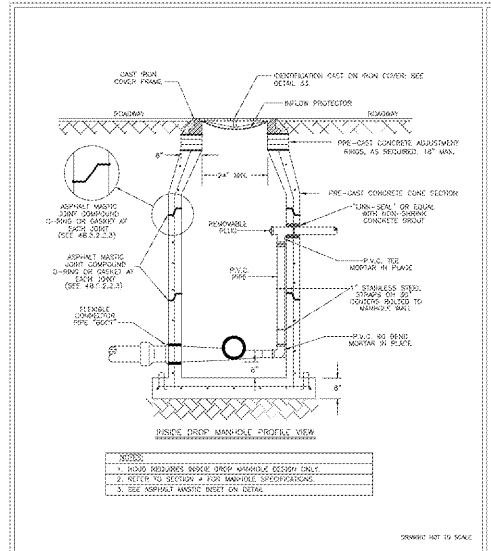

HERNANDO COUNTY UTILITIES DEPARTMENT
21030 CORTEZ BOULEVARD
BROOKSVILLE, FLORIDA 34601
OFFICE: (352) 754-4037 FAX: (352) 754-4485

MANHOLE TYPICAL & INSIDE DROP INSTALLATION DETAIL
DETAIL: 32
PAGE D-33
DATE: JANUARY 2013

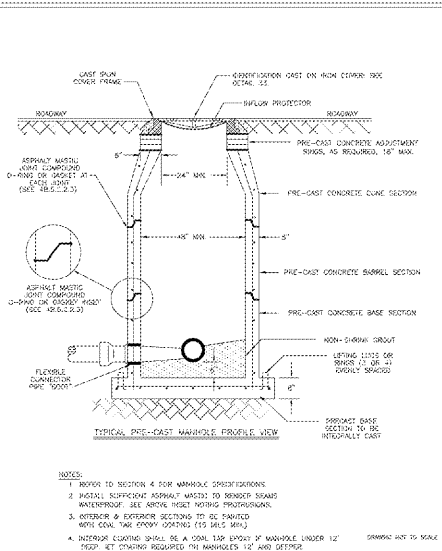

HERNANDO COUNTY UTILITIES DEPARTMENT
21030 CORTEZ BOULEVARD
BROOKSVILLE, FLORIDA 34601
OFFICE: (352) 754-4037 FAX: (352) 754-4485

MANHOLE TYPICAL & INSIDE DROP INSTALLATION DETAIL
DETAIL: 32
PAGE D-33
DATE: JANUARY 2013

NOTE:
DETAILS CONTAINED ON THIS PAGE WERE CREATED BY THE LOCAL JURISDICTION THEY SERVE.
ENGINEER OF RECORD IS NOT THE AUTHOR IN ANY WAY OF THESE DETAILS AND CLAIMS NO RESPONSIBILITY FOR ACCURACY OR RELEVANCE AS THEY ARE PROVIDED AS A DIRECT REQUIREMENT OF THE UTILITY PROVIDER. CONTRACTOR SHALL ALSO REFER TO THE LOCAL JURISDICTIONAL PUBLICLY AVAILABLE SPECIFICATIONS.

| NO. | DATE | BY | REVISIONS |
|-----|----------|-----|------------------------------|
| 1 | 02/12/18 | AVF | PER HERNANDO COUNTY COMMENTS |
| 2 | | | |
| 3 | | | |
| 4 | | | |

CADD Tech: AVF
Designer: AVF
Engineer: SAL

Project No: -
Scale: -
Date: 10/21/17

PALMETTO CAPITAL GROUP, INC.

L.A. Civil, Inc.
Certificate of Authorization # 00029995
PO BOX 7649
Clearwater, Florida 33758-7649
Phone: 727-446-9000

DOLLAR GENERAL
SEC US 19 AND PINE FOREST DRIVE
HERNANDO COUNTY, FL

HERNANDO COUNTY UTILITY STANDARD DETAILS

PROJECT TITLE

SHEET TITLE

SHEET No.
C7.2