

- NOTES:
1. SIDEWALKS SHALL HAVE TOOLED EDGES.
 2. CONSTRUCTION JOINTS SHALL BE LOCATED AT STRUCK JOINTS OR EXPANSION JOINTS ONLY.
 3. THIS DETAIL IS FOR ON-SITE CONDITIONS ONLY. DO NOT USE FOR RIGHT-OF-WAY CONSTRUCTION.
 4. REFER TO FDOT INDEX #310 AND CORRESPONDING SPECIFICATIONS FOR SIDEWALKS WITHIN THE RIGHT OF WAY.

SIDEWALK STANDARD DETAIL

NTS

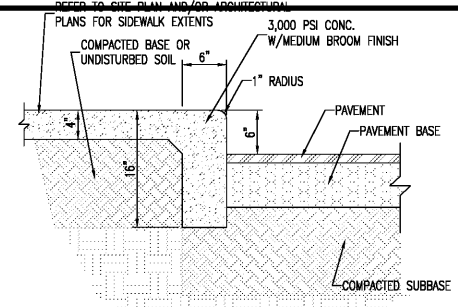

- NOTES:
1. PROVIDE 1/4" CONTROL JOINTS @ 5'-0" O.C.
 2. PROVIDE 1/2" BITUMINOUS EXPANSION JOINTS @ 50' O.C.
 3. THIS DETAIL IS FOR ON-SITE CONDITIONS ONLY. DO NOT USE FOR RIGHT-OF-WAY CONSTRUCTION.

SIDEWALK CURB DETAIL

NTS

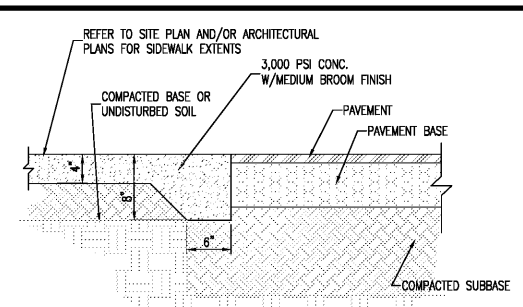

- NOTES:
1. PROVIDE 1/4" CONTROL JOINTS @ 5'-0" O.C.
 2. PROVIDE 1/2" BITUMINOUS EXPANSION JOINTS @ 50' O.C.
 3. THIS DETAIL IS FOR ON-SITE CONDITIONS ONLY. DO NOT USE FOR RIGHT-OF-WAY CONSTRUCTION.

FLUSH SIDEWALK DETAIL

NTS

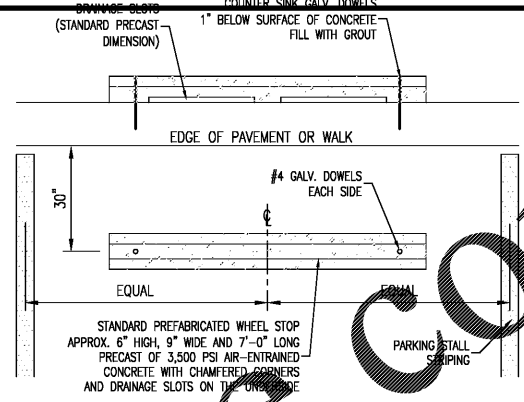

WHEELSTOP DETAIL

NTS

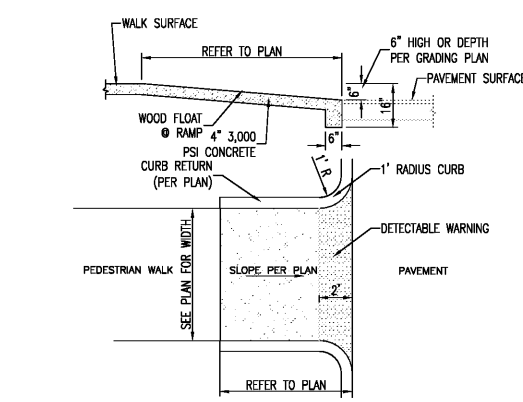

END HANDICAP RAMP DETAIL

NTS

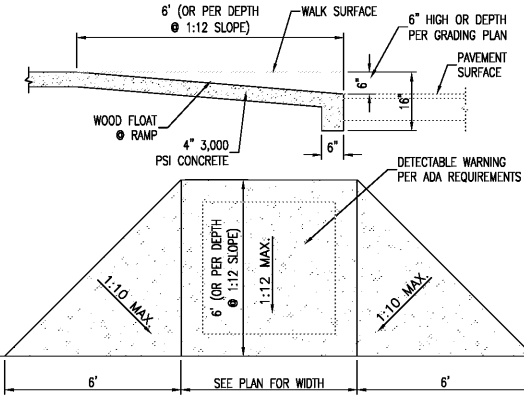

FLARED HANDICAP RAMP

NTS

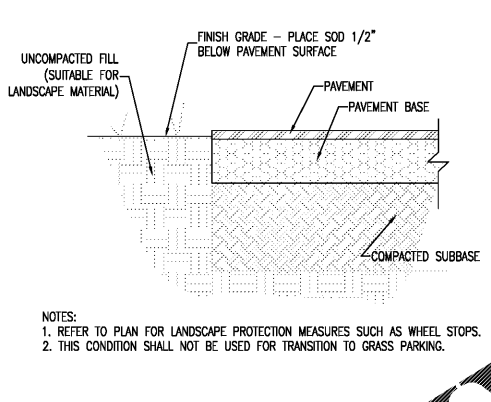

PLACEMENT OF SOD AT PAVEMENT

NTS

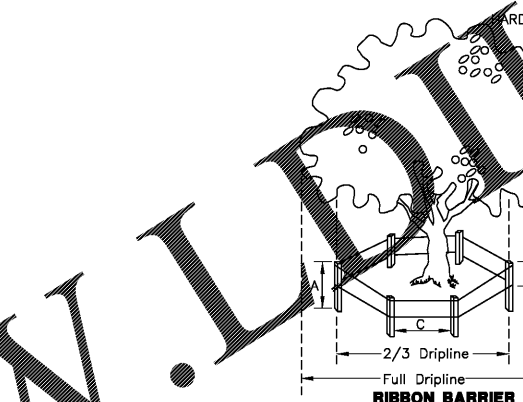

TREE BARRICADE DETAIL

NTS

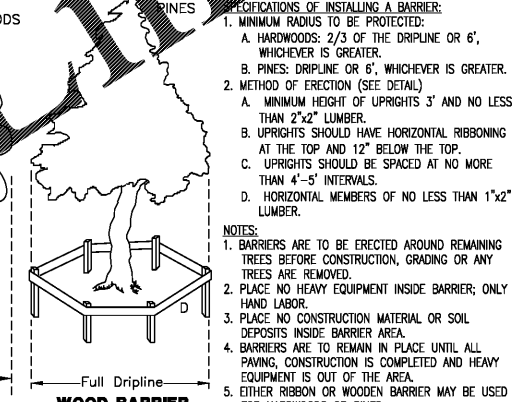

WOOD BARRIER DETAIL

NTS

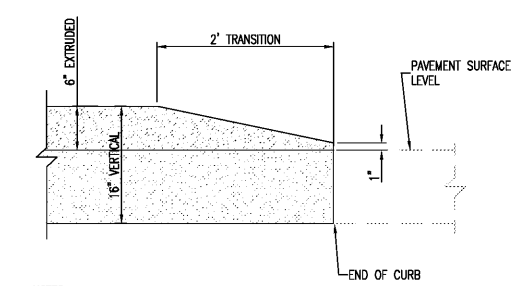

CURB TRANSITION DETAIL

NTS

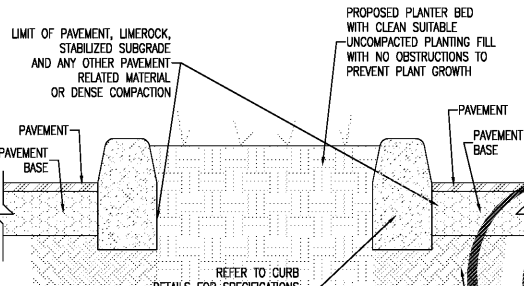

CURB PLACEMENT AT PLANTER

NTS

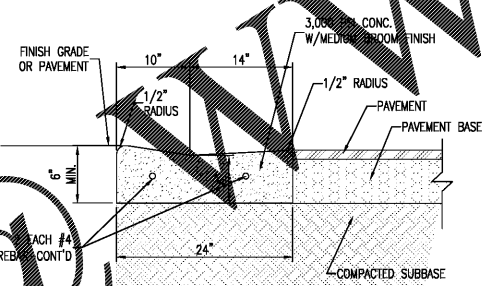

DROP CURB DETAIL

NTS

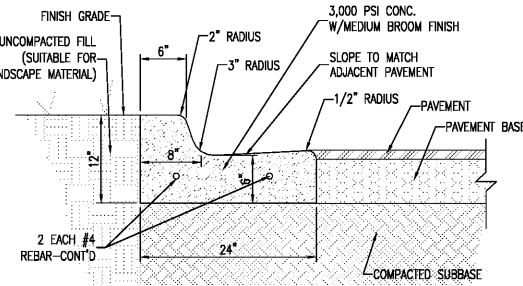

CURB AND GUTTER DETAIL

NTS

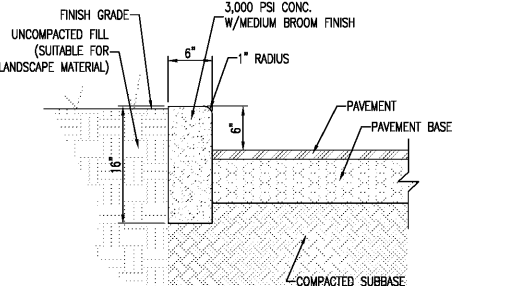

VERTICAL CURB DETAIL

NTS

CONCRETE PAVEMENT END DETAIL

NTS

CONCRETE PAVEMENT DETAIL

NTS

HEAVY PAVEMENT DETAIL

NTS

STANDARD PAVEMENT DETAIL

NTS

ON-SITE PAVEMENT AND CURB NOTES AND SPECIFICATIONS

1. ALL PAVEMENT AND CURB DETAILS CONTAINED ON THIS PAGE ARE FOR ON-SITE PRIVATE VEHICULAR USE AREAS ONLY.
2. ALL PAVEMENT AND CURB WITHIN THE PUBLIC RIGHT OF WAY SHALL BE PER THE LOCAL JURISDICTIONAL DETAILS AND SPECIFICATIONS OF THAT RIGHT OF WAY.
3. REFER TO OTHER DETAIL PAGES OR REFERENCE MATERIALS CALLED OUT ON THE PLAN CONTAINING STANDARD DETAILS FOR RIGHT OF WAY WORK.

CONCRETE PAVEMENT END DETAIL

NTS

CONCRETE PAVEMENT DETAIL

NTS

HEAVY PAVEMENT DETAIL

NTS

STANDARD PAVEMENT DETAIL

NTS

Project No.	Scale	Date
AVF	AVF	SAL
Designer	Engineer	
CADD Tech		

Revisions	By	Date
1	AVF	02/12/18
2	AVF	02/12/18
3	AVF	02/12/18
4	AVF	02/12/18

PALMETTO CAPITAL GROUP, INC.

1-A Civil, Inc.
 Certificate of Authorization # 00029995
 PO BOX 7649
 Clearwater, Florida 33758-7649
 Phone: 727-446-9000

DOLLAR GENERAL
 SEC US 19 AND PINE FOREST DRIVE
 HERNANDO COUNTY, FL

ON-SITE PAVEMENT, CURB AND WALK DETAILS

PROJECT TITLE

SHEET TITLE

SHEET No.
C6.1