

OWNER:

ROSS STORES

5130 HACIENDA DRIVE
DUBLIN, CA 94568

PROJECT:

dd's
DISCOUNTS
STORE #5352
(GREENVILLE, SC)

WHITE
HORSE PLAZA
6119 WHITE HORSE ROAD
GREENVILLE, SC 29611

BASED ON DD'S
22K TURNKEY - EXISTING
PROTOTYPE DATED MARCH, 2018

DRAWING TITLE:
SECTIONS & DETAILS

REV. NO. DATE DESCRIPTION
01/02/18 FOR ROSS REVIEW
03/17/18 ROSS MARK-UP'S

APPROVED BY:
ANTHONY CASSATA
COKK BROOK, IL 60523
REGISTERED ARCHITECT

EXPIRES: 6/30/2018

COPYRIGHT: ALL DRAWN AND
WRITTEN INFO. APPEARING
HEREIN SHALL NOT BE
DUPLICATED, DISCLOSED
OR OTHERWISE
WITHOUT WRITTEN CONSENT.

PFDA JOB: #16027

SCALE
AS NOTED

DRAWN BY: CHECKED BY:

SHEET NUMBER

A5.1

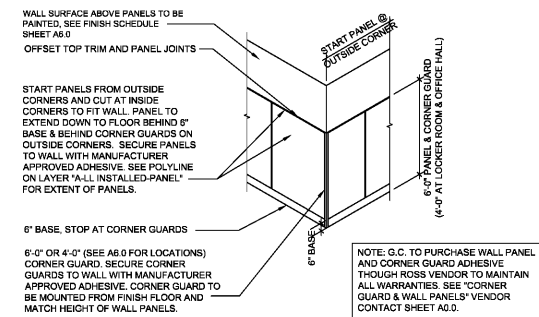

1 WALL PANEL DETAIL
A5.1 SCALE: NONE SEE SEC.7 SHEET-G1.0

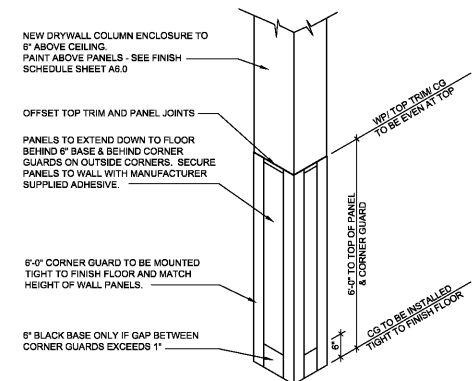

1A COLUMN PANEL DETAIL
A5.1 SCALE: NONE

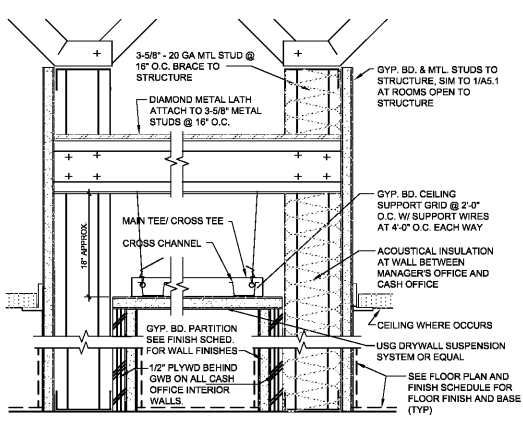

2 SECTION @ CASH OFFICE
A5.1 SCALE: 3" = 1'-0" SEE SEC.7.5 SHEET-G1.0

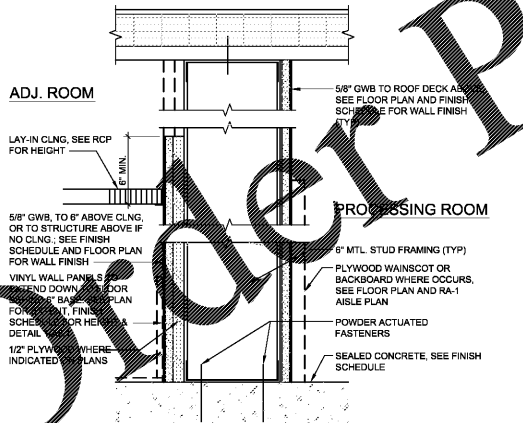

3 PROCESSING RM WALL SECTION
A5.1 SCALE: 3" = 1'-0" SEE SEC.7.1 & 7.5 SHEET-G1.0

4 NOT USED
A5.1

5 NOT USED
A5.1

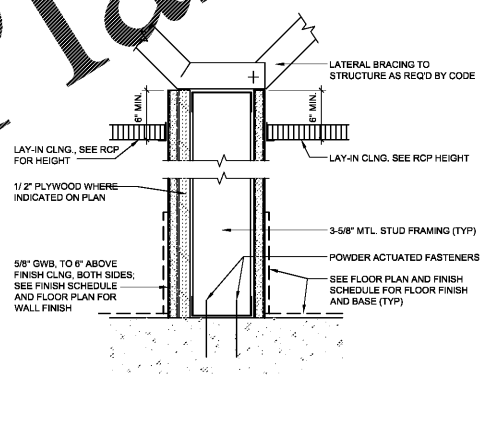

6 CEILING HEIGHT WALL SECTION
A5.1 SCALE: 3" = 1'-0"

7 FULL HT. WALL @ ELEC. ROOM
A5.1 SCALE: 3" = 1'-0" SEE SEC.7.1 & 7.4 SHEET-G1.0

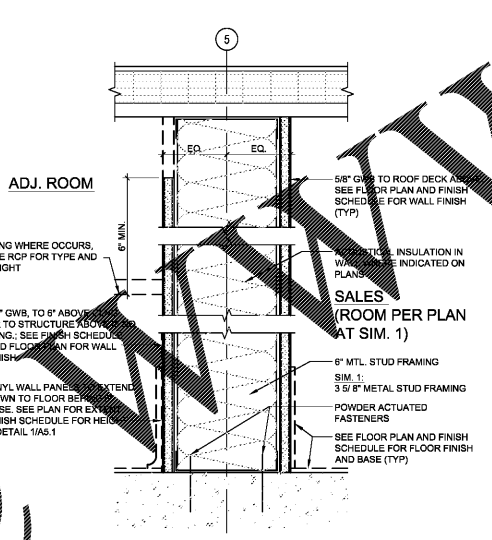

8 INT. FULL HT. WALL SECTION
A5.1 SCALE: 3" = 1'-0" SEE SEC.7.1 & 7.3 SHEET-G1.0

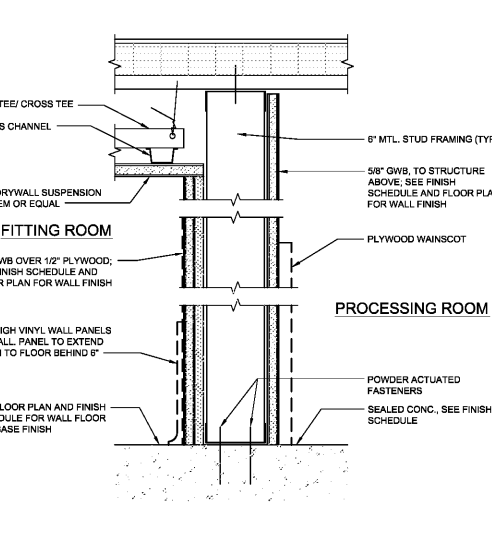

9 FULL HT. WALL @ FITTING RM
A5.1 SCALE: 3" = 1'-0"

10 RESTROOM PARTITION WALL
A5.1 SCALE: 3" = 1'-0" SEE SEC.7.6 & 7.7 SHEET-G1.0

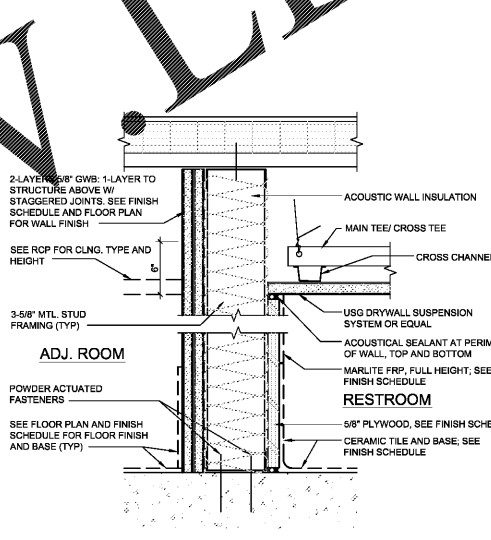

11 RESTROOM ACOUSTICAL WALL
A5.1 SCALE: 3" = 1'-0" SEE SEC.7.6 & 7.7 SHEET-G1.0

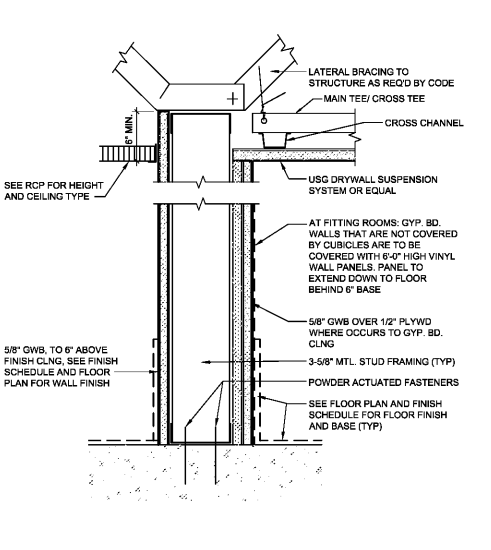

12 FITTING RM PARTITION WALL
A5.1 SCALE: 3" = 1'-0"

13 PLAN AT NEW COLUMN ENCL.
A5.1 SCALE: NONE

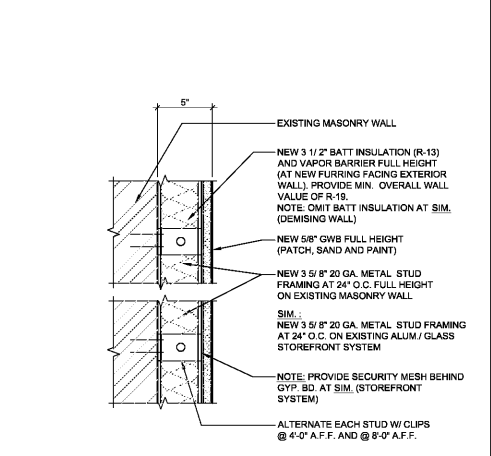

14 FURRING AT EXIST. WALL
A5.1 SCALE: 3" = 1'-0"

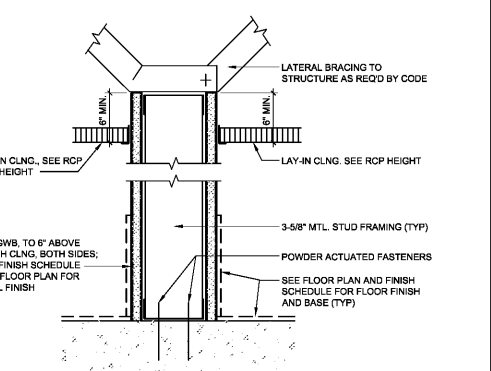

15 CEILING HT. WALL SECTION
A5.1 SCALE: 3" = 1'-0" SEE SEC.7 SHEET-G1.0

Order Plans @