

These drawings and specifications are owned and copyrighted by GUY PAYNE & ASSOCIATES ARCHITECTS and may not be used, copied or duplicated without written consent. Any information contained herein may be subject to change without notice. Criminal and civil penalties and sanctions apply.

GUY PAYNE & ASSOCIATES ARCHITECTS P.C.
 879 Willow Tree Circle, Suite 114
 Concord, TN 38018
 901.756.1878(P) 901.756.1879(F)

NEW COMMUNITY CENTER FOR
Hickory Chase Apartments
 600 HERITAGE DRIVE
 MADISON, TN

Bernice Allen
 ARCHITECT
 12.13.17

DATE	NO.
PROJECT NUMBER	
DATE OF ORIGINAL ISSUE	12/13/17
SHEET NUMBER	

M2

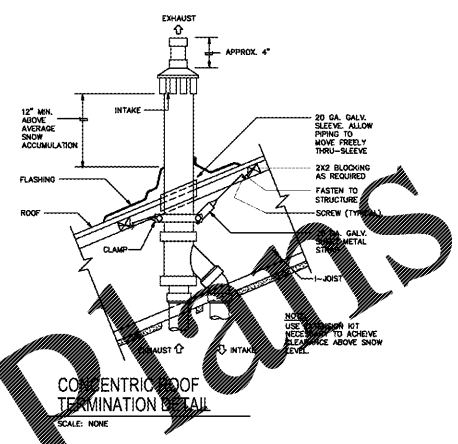
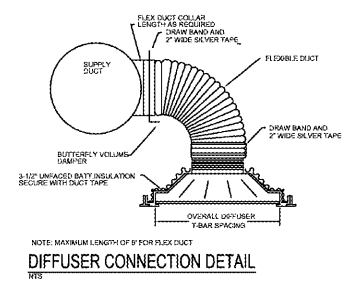
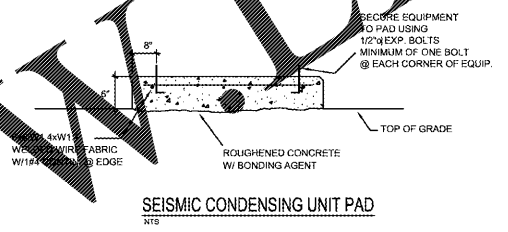
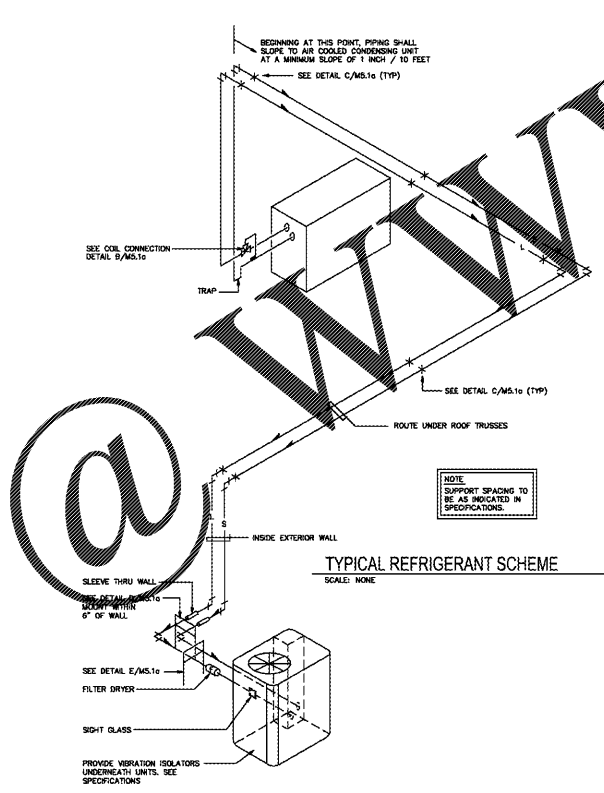
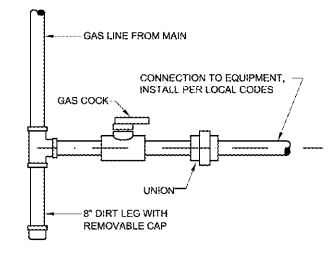
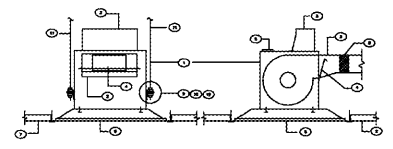
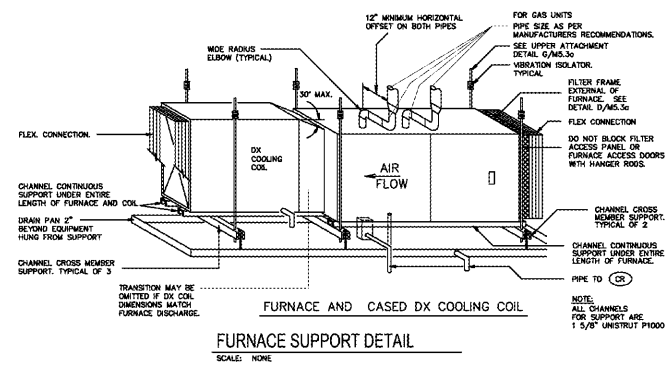

Order Plans

WWW.WALDLINE.COM