

1 PROPOSED FLOOR PLAN
1/4" = 1'-0"

OCCUPANCY CALCULATIONS

ROOM CALCULATIONS FOR (A-2) OCC.

Rooms	Area	Occupancy	Occupant
ADA R.R.	52 SF	1:200	1
BAR	954 SF	15	15
HALL	Redundant	15	11
HOST ENTRY	123 SF	15	8
KITCHEN	Redundant	200	
MAIN DINING AREA	1523 SF	15	(150 - 6) = 94
MENS R.R.	18 SF	100	1
OUTDOOR PATIO	72 SF	15	71
WALK-IN-FREEZER	Redundant	200	7
WOMENS R.R.	15 SF	100	1
Area Total:	5414 S.F.	Occupancy:	211 OCC.

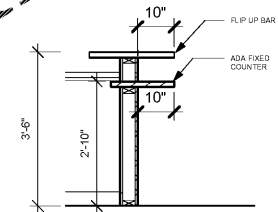

2 ADA BAR SECTION
1/2" = 1'-0"

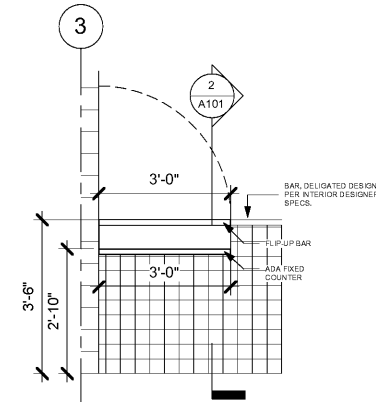

3 ADA BAR ELEVATION
1/2" = 1'-0"

DOOR SCHEDULE

Mark	Width	Height	Comments
100	2'-6"	6'-8"	TO BE SELECTED BY OWNER & CONTRACTOR; SPECIFIED BY MANUFACTURER
101	5'-0"	6'-8"	TO BE SELECTED BY OWNER & CONTRACTOR; SPECIFIED BY MANUFACTURER
102	3'-0"	6'-8"	TO BE SELECTED BY OWNER & CONTRACTOR; SPECIFIED BY MANUFACTURER
103	3'-0"	8'-0"	TO BE SELECTED BY OWNER & CONTRACTOR; SPECIFIED BY MANUFACTURER
104	3'-0"	8'-0"	TO BE SELECTED BY OWNER & CONTRACTOR; SPECIFIED BY MANUFACTURER

Grand total: 5

LAPEER RESTAURANT
8 SOUTH MAIN STREET ALPHARETTA, GEORGIA 30009

BALDWIN
ARCHITECTURAL GROUP
M. Christopher Baldwin, Architect
6017 Sandy Springs Cir.
Atlanta, GA 30328
(404) 406-9041

Copyright Ownership
This drawing is the property of M.C. Baldwin, Arch. and may not be used, copied, or revised without expressed written permission.

Revision

No.	Date	By

DATE: 11/19/2017
DRAWN: SAY
CHECKED: MCB

JOB NO.
20170911

SHEET NO.
A101