

TRACTION PASSENGER ELEVATOR	
SCHINDLER ELEVATOR CORP. - MODEL 3300 - TRACTION ELEVATOR. OTHER ACCEPTABLE MANUF. OTIS AND DOVER	
APPLICATION	3500 LB. 5 STOP TRACTION PASSENGER/SERVICE
SERVICE	1 PER BLDG.
QUANTITY	3500 LBS.
CAPACITY	100FPM
SPEED	82 FT. MAX
TRAVEL	5
LANDINGS	0
FRONT OPENING	5
REAR OPENING	0
OPERATION	MICROPROCESSOR SINGLE CAR
MACHINE ROOM	N.A.
PLATFORM SIZE	6'-9"x5'-7"
DOOR TYPE	TWO 8'-0" SIDE OPENING
CAB HEIGHT	7'-0"
GUIDE RAILS	EQ. TO 10 LB PER FOOT
HOISTWAY ENTRANCE	3'-4" x 7'-0"
POWER SUPPLY	208 V 3 PHASE 60 HZ

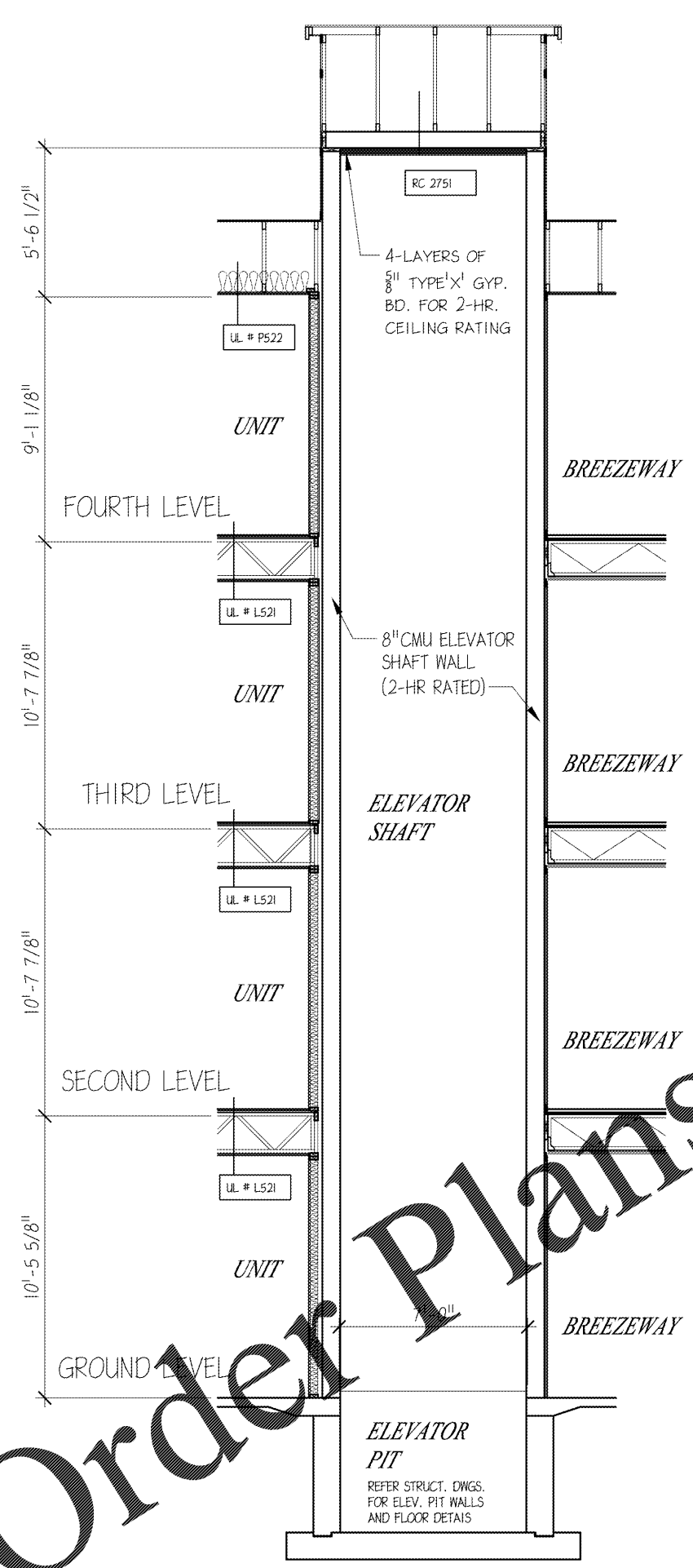

1 ELEVATOR SHAFT SECTION
SCALE: 3/8" = 1'-0"

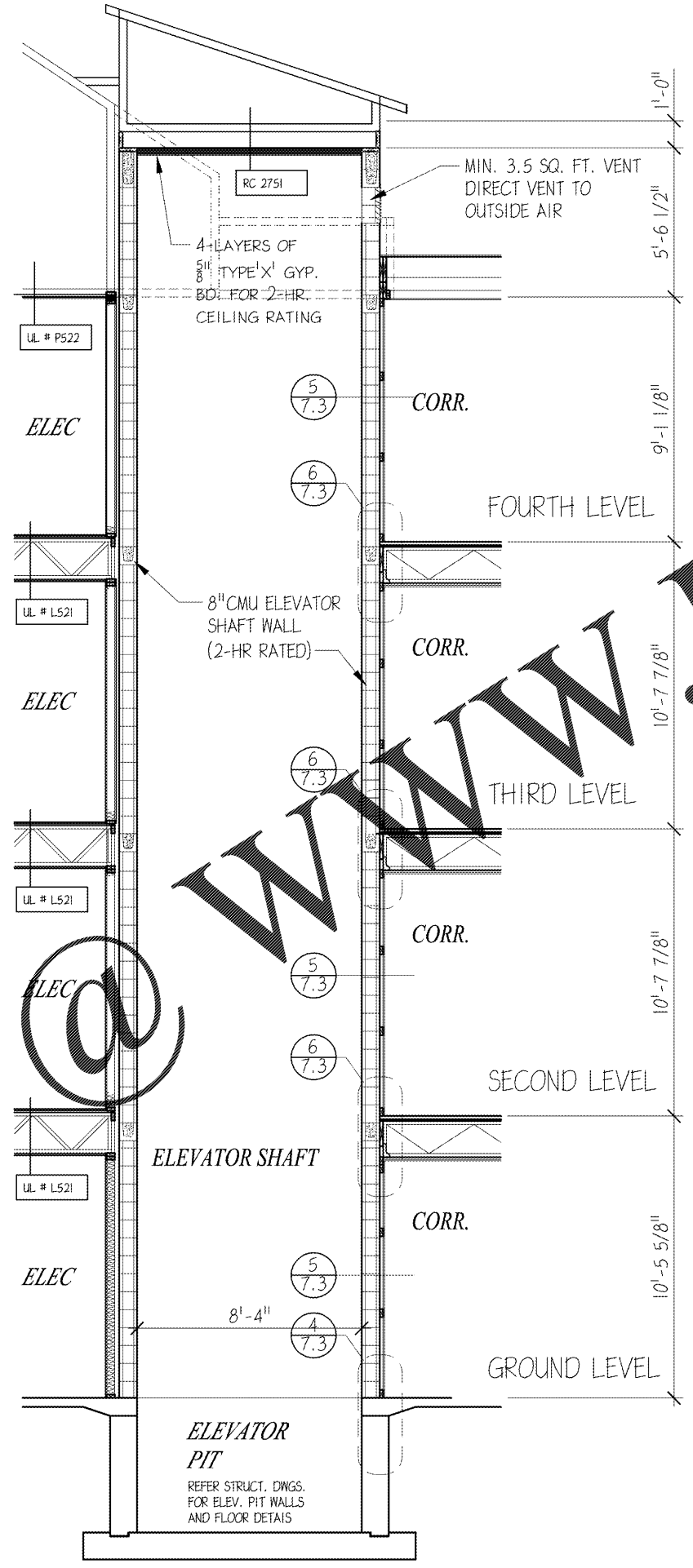

2 ELEVATOR SHAFT SECTION
SCALE: 3/8" = 1'-0"

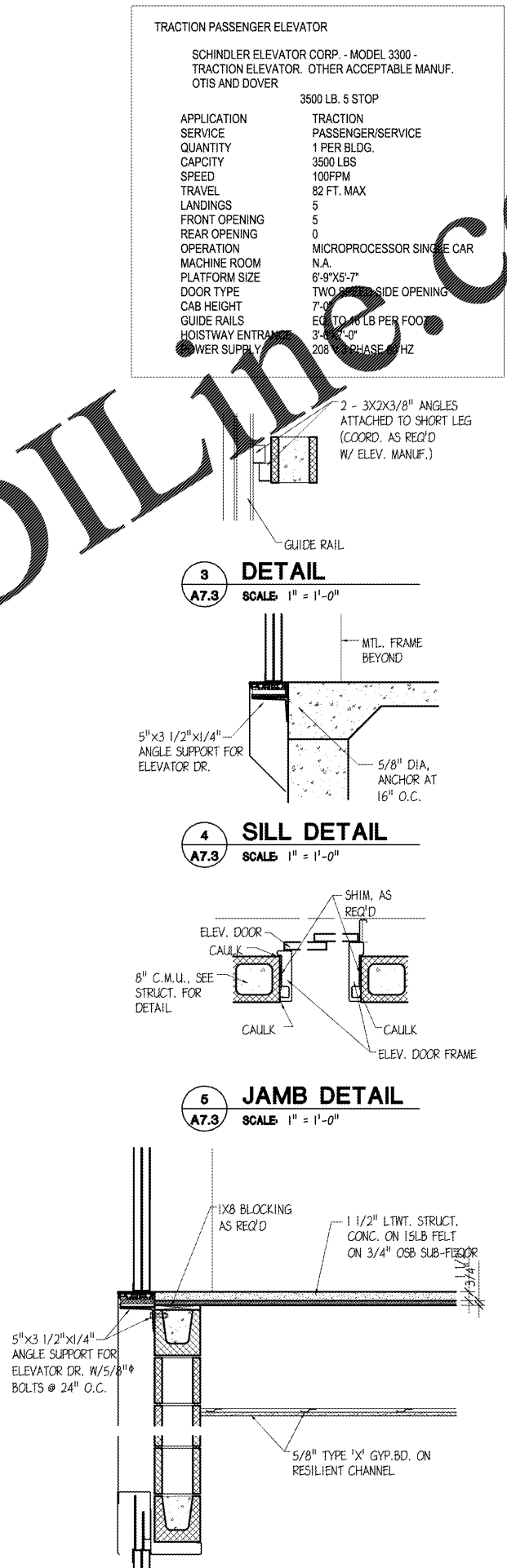

6 HEAD & SILL DETAIL
SCALE: 1" = 1'-0"

3 DETAIL
SCALE: 1" = 1'-0"

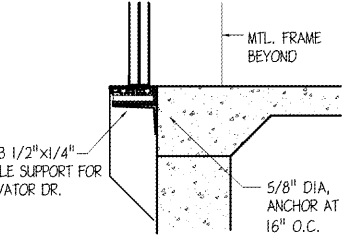

4 SILL DETAIL
SCALE: 1" = 1'-0"

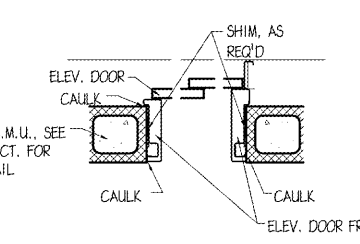

5 JAMB DETAIL
SCALE: 1" = 1'-0"

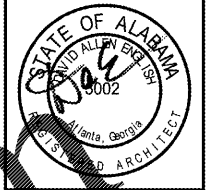
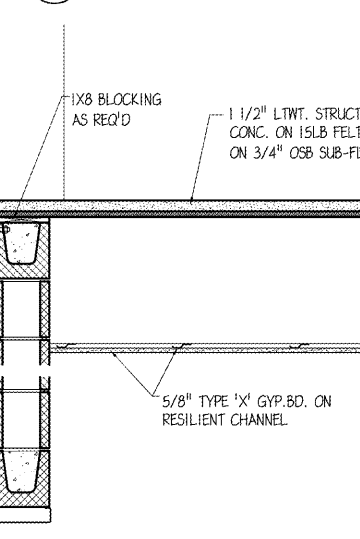

PUCCIANO & ENGLISH, INC.
ARCHITECTS, AIA
3084 MERCER UNIVERSITY DRIVE, SUITE 110
ATLANTA, GA 30341
PH 770-457-4823; FAX 770-451-0082
denglish@pucciano-english.com



JOB No: 1701
DRAWN BY:
CHECK BY:
JOB PROGRESS:
ITEM DATE
PRICING SET 07-14-2017
PERMIT SET 02-26-2018

REVISIONS:
DATE NO.

This drawing, as an instrument of service, is and shall remain the property of the Architect and shall not be reproduced, published or used in any way without the permission of the Architect.

Legacy at Jones Farm Phase 2
HUNTSVILLE, ALABAMA
AN APARTMENT COMMUNITY FOR
RBJ BAILEY, LLC

ELEVATOR SECTIONS
SHEET NO.

A7.3