

NOTE: REFER TO 15/A4.1 FOR FLOOR SPACE CLEARANCES DIAGRAM.

NOTE: REFER TO OVERALL FLOOR PLAN FOR RESTROOM ORIENTATION AND LAYOUT OF ADJACENT WALLS.

SPECIAL NOTE: REFER TO PRE-ENGINEERED METAL BUILDING SHOP DRAWINGS FOR LOCATIONS OF INDEPENDENT STRUCTURAL VERTICAL LATERAL BRACING SYSTEMS AND NOTIFY OWNER'S REPRESENTATIVE AND ARCHITECT IF BRACING OCCURS ADJACENT TO RESTROOM PERIMETER WALLS. ENTIRE RESTROOM LAYOUT TO SHIFT 6' AWAY FROM BRACING WALL(S) TO CONCEAL STRUCTURE.

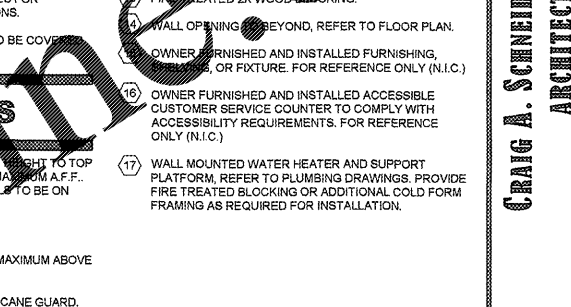
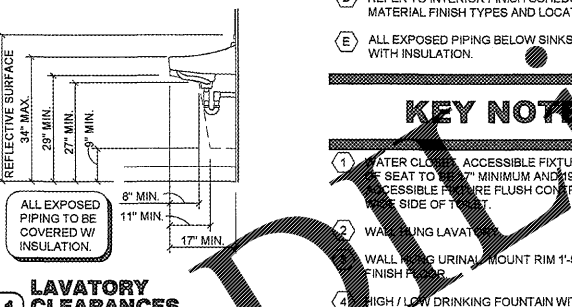
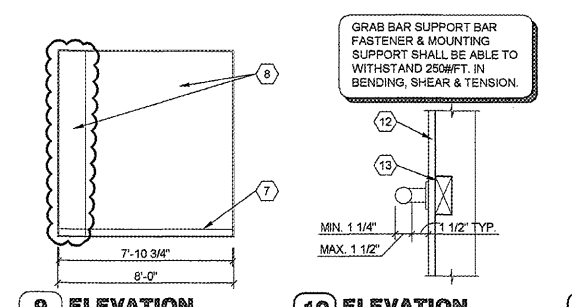
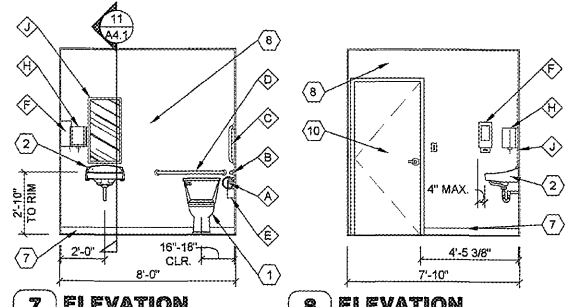

1 ENLARGED PLAN  
A4.1 SCALE: 1/4" = 1'-0"

7 ELEVATION  
A4.1 SCALE: 1/4" = 1'-0"

8 ELEVATION  
A4.1 SCALE: 1/4" = 1'-0"

9 ELEVATION  
A4.1 SCALE: 1/4" = 1'-0"

10 ELEVATION  
A4.1 SCALE: 1/4" = 1'-0"

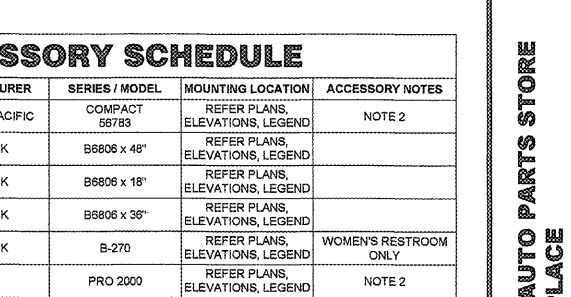
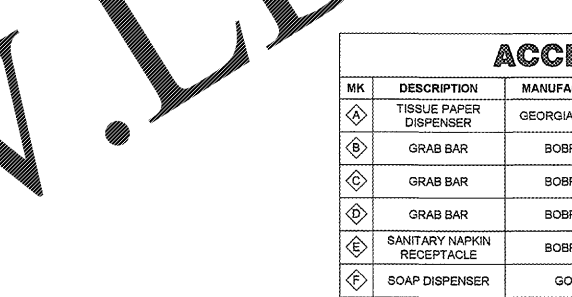
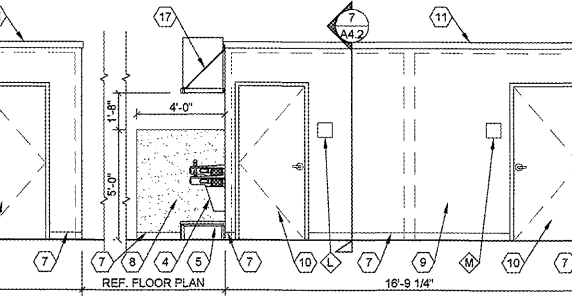
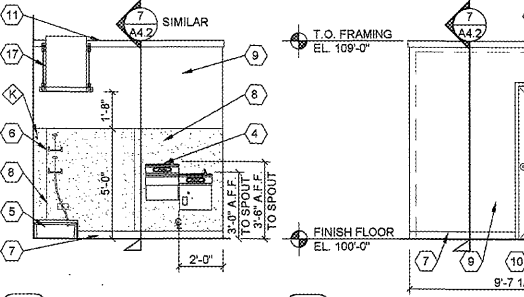

12 ELEVATION  
A4.1 SCALE: 1/4" = 1'-0"

13 ELEVATION  
A4.1 SCALE: 1/4" = 1'-0"

14 ELEVATION  
A4.1 SCALE: 1/4" = 1'-0"

15 FLOOR SPACE CLEARANCES DIAGRAM  
A4.1 SCALE: 1/4" = 1'-0"

### GENERAL NOTES

- A REFER TO PROJECT MANUAL FOR ADDITIONAL REQUIREMENTS.
- B LAYOUT DIMENSIONS OF PLUMBING FIXTURES AND ACCESSORIES TO FACE OF GYPSUM BOARD OR CENTER LINE OF FIXTURE. LAYOUT DIMENSIONS OF WALLS AND CEILINGS TO ROUGH FACE OF FRAMING, MASONRY, OR CENTER LINE OF STRUCTURE. ALL GYPSUM BOARD 5/8" THICK UNLESS OTHERWISE INDICATED AND DIMENSIONS NOT SHOWN FOR CLARITY.
- C REFER TO PLUMBING DRAWINGS FOR FIXTURE TYPES AND ADDITIONAL REQUIREMENTS. PROVIDE ADDITIONAL COLD FORM METAL FRAMING OR FIRE TREATED BLOCKING AS REQUIRED FOR PROPER SUPPORT.
- D REFER TO INTERIOR FINISH SCHEDULES FOR MATERIAL FINISH TYPES AND LOCATIONS.
- E ALL EXPOSED PIPING BELOW SINKS TO BE COVERED WITH INSULATION.

### KEY NOTES

- 6 EYE WASH STATION. INSTALL WITH TOP AT 48" ABOVE FINISH FLOOR.
- 7 BASE, REFER TO FINISH SCHEDULE.
- 8 SANITARY WALL PANEL SYSTEM, REFER TO FINISH SCHEDULE. PROVIDE TRIM AND EDGE MOLDING AROUND PERIMETER. ATTACH TO SUBSTRATE AS REQUIRED.
- 9 PAINT, REFER TO FINISH SCHEDULE.
- 10 DOOR, REFER TO DOOR AND FINISH SCHEDULES.
- 11 WOOD TRIM, PAINT, REFER TO FINISH SCHEDULE.
- 12 WALL CONSTRUCTION, REFER TO FLOOR PLAN FOR TYPES.
- 13 FINISH TREATED 2X WOOD BLOCKING.
- 14 WALL OPENING, REFER TO FLOOR PLAN.
- 15 OWNER FURNISHED AND INSTALLED FURNISHING, FIXTURES, OR FIXTURE. FOR REFERENCE ONLY (N.I.C.)
- 16 OWNER FURNISHED AND INSTALLED ACCESSIBLE CUSTOMER SERVICE COUNTER TO COMPLY WITH ACCESSIBILITY REQUIREMENTS. FOR REFERENCE ONLY (N.I.C.)
- 17 WALL MOUNTED WATER HEATER AND SUPPORT PLATFORM, REFER TO PLUMBING DRAWINGS. PROVIDE FIRE TREATED BLOCKING OR ADDITIONAL COLD FORM FRAMING AS REQUIRED FOR INSTALLATION.

### KEY NOTES

- 1 WATER CLOSING ACCESSIBLE FIXTURE HEIGHT TO TOP OF SEAT TO BE 17" MINIMUM AND 19" MAXIMUM A.F.F. ACCESSIBLE FIXTURE FLUSH CONTROL TO BE ON OPPOSITE SIDE OF TOILET.
- 2 WALL MOUNTED LAVATORY.
- 3 WALL MOUNTED URINAL. MOUNT RIM 1'-5" MAXIMUM ABOVE FINISH FLOOR.
- 4 HIGH / LOW DRINKING FOUNTAIN WITH CANE GUARD.
- 5 FLOOR MOUNTED MOP BASIN.

### ACCESSORY SCHEDULE

MK	DESCRIPTION	MANUFACTURER	SERIES / MODEL	MOUNTING LOCATION	ACCESSORY NOTES
A	TISSUE PAPER DISPENSER	GEORGIA PACIFIC	COMPACT 56783	REFER PLANS, ELEVATIONS, LEGEND	NOTE 2
B	GRAB BAR	BOBRICK	B8806 x 48"	REFER PLANS, ELEVATIONS, LEGEND	
C	GRAB BAR	BOBRICK	B8806 x 18"	REFER PLANS, ELEVATIONS, LEGEND	
D	GRAB BAR	BOBRICK	B8806 x 36"	REFER PLANS, ELEVATIONS, LEGEND	
E	SANITARY NAPKIN RECEPTACLE	BOBRICK	B-270	REFER PLANS, ELEVATIONS, LEGEND	WOMEN'S RESTROOM ONLY
F	SOAP DISPENSER	GOJO	PRO 2000	REFER PLANS, ELEVATIONS, LEGEND	NOTE 2
G	PAPER TOWEL DISPENSER (MEN)	GEORGIA PACIFIC	59460	REFER PLANS, ELEVATIONS, LEGEND	NOTE 2
H	PAPER TOWEL DISPENSER (WOMEN)	GEORGIA PACIFIC	SOFPULL 52409	REFER PLANS, ELEVATIONS, LEGEND	NOTE 2
I	MIRROR	BOBRICK	B-165-1635 18" W X 36" H	REFER PLANS, ELEVATIONS, LEGEND	
J	MOP HANGER	REFER TO PLUMBING DRAWINGS	REFER TO PLUMBING DRAWINGS	54" A.F.F. TO CENTER	REFER TO PLUMBING DRAWINGS
K	DOOR SIGN (MEN)	ROCKWOOD	BF687	REFER PLANS, ELEVATIONS, LEGEND	WHITE TEXT ON BLACK BACKGROUND
L	DOOR SIGN (WOMEN)	ROCKWOOD	BF688	REFER PLANS, ELEVATIONS, LEGEND	WHITE TEXT ON BLACK BACKGROUND

ACCESSORY GENERAL NOTES:  
 1. CONTRACTOR TO PROVIDE FIRE TREATED WOOD BLOCKING FOR INSTALLATION OF TOILET ACCESSORIES, INCLUDING OWNER FURNISHED AND CONTRACTOR INSTALLED ACCESSORIES. COORDINATE REQUIREMENTS WITH OWNER.  
 2. ACCESSORY OWNER FURNISHED AND CONTRACTOR INSTALLED. REFER TO SCOPE OF WORK SCHEDULE FOR ADDITIONAL REQUIREMENTS.

### ACCESSORY MOUNTING LEGEND

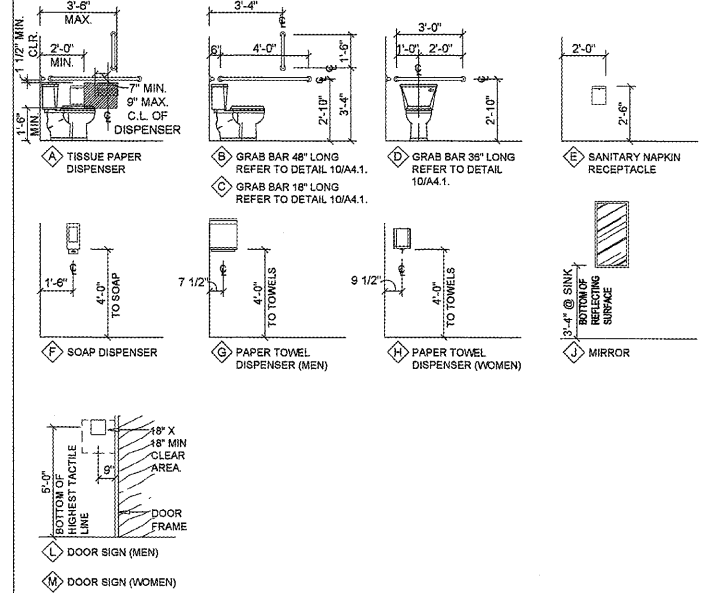

Order Plans @

WWW.LDLINE.COM

**CRAIG A. SCHNEIDER, AIA**  
 ARCHITECT  
 417.862.0000  
 1736 East Trenching, Suite 417  
 Springfield, Missouri 65804  
 e-mail: architect@esterjschneider.com

**PROJECT:**  
 NEW O'REILLY AUTO PARTS STORE  
 SLIDING HILL PLACE  
 ASHLAND, VA #2 - ASHLAND MAGISTERIAL DISTRICT  
**INTERIOR ELEVATIONS**

**O'Reilly AUTO PARTS**  
 CORPORATE OFFICES  
 233 SOUTH PATTERSON  
 (417) 862-2674 TELEPHONE

COMM #	3993
DATE:	2-24-17
REVISION	
DATE:	8-16-17
	11-16-17