

1 SHEET METAL PLENUM
NO SCALE

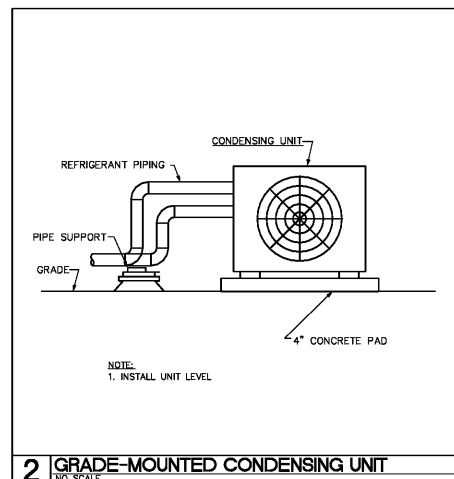

2 GRADE-MOUNTED CONDENSING UNIT
NO SCALE

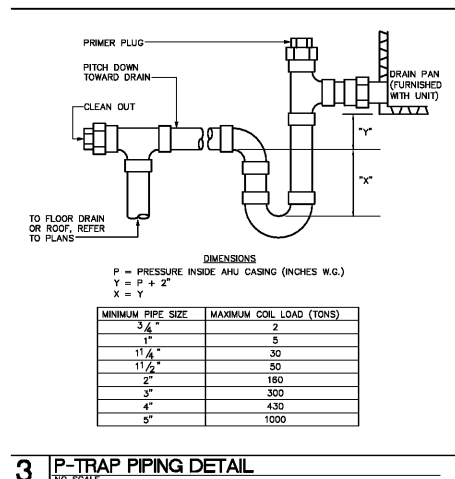

3 P-TRAP PIPING DETAIL
NO SCALE

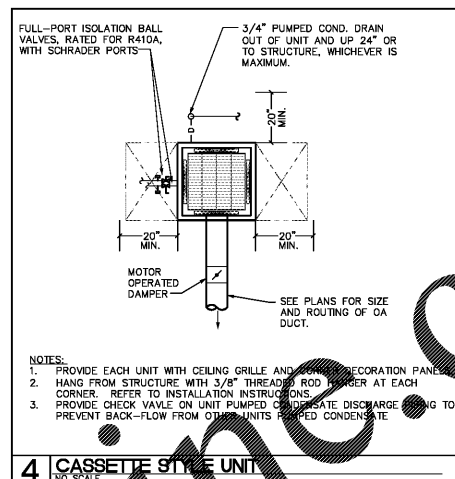

4 CASSETTE STYLE UNIT
NO SCALE

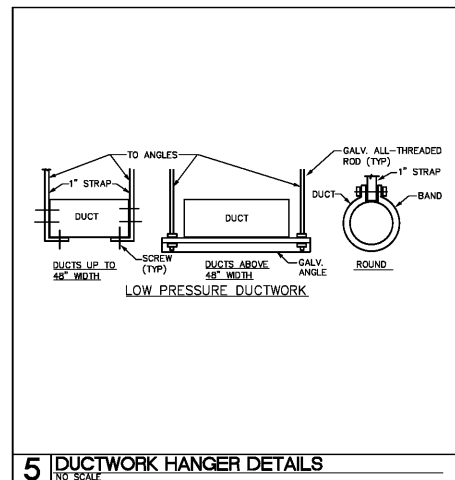

5 DUCTWORK HANGER DETAILS
NO SCALE

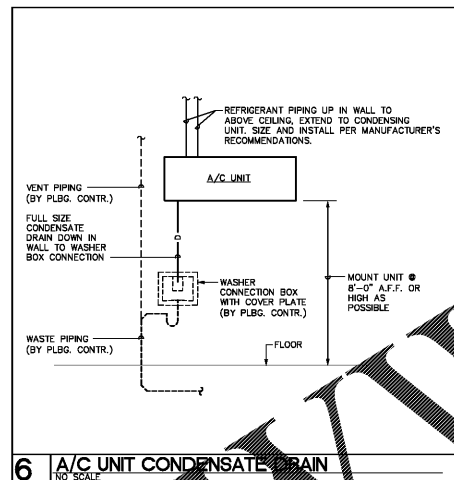

6 A/C UNIT CONDENSATE DRAIN
NO SCALE

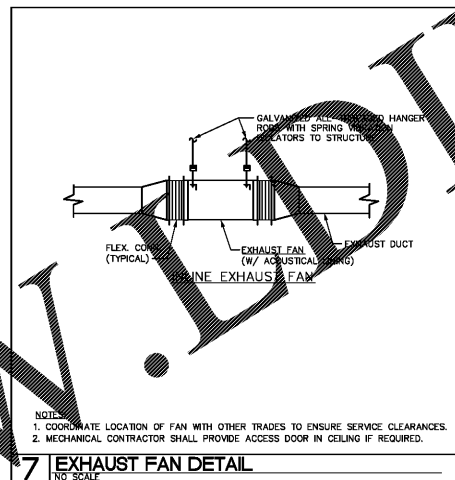

7 EXHAUST FAN DETAIL
NO SCALE

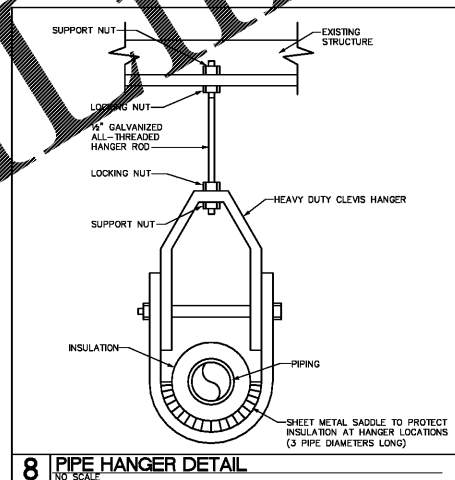

8 PIPE HANGER DETAIL
NO SCALE

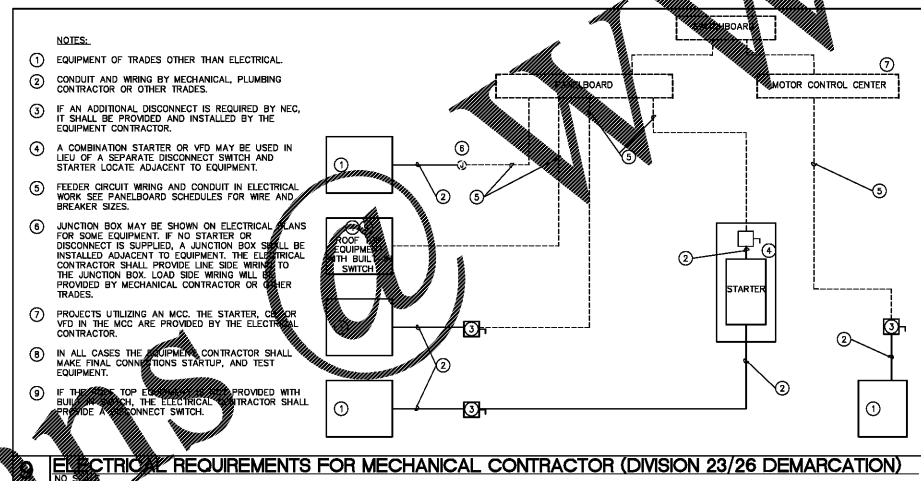

9 ELECTRICAL REQUIREMENTS FOR MECHANICAL CONTRACTOR (DIVISION 23/26 DEMARCATION)
NO SCALE

Order Plans

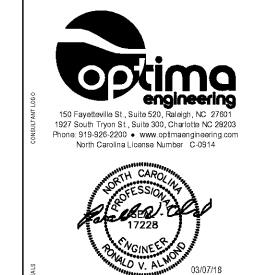

WESTERN CAROLINA UNIVERSITY
MOORE HALL GROUND FLOOR RENOVATION
CULLOWHEE, NC

SHEET ISSUE

NO.	DATE	DESCRIPTION	BY
1	03/07/18	ISSUED FOR BID	

PRINCIPAL IN CHARGE: LR
PROJECT ARCHITECT: APR
DRAWN BY:
SHEET TITLE: MECHANICAL DETAILS

SHEET NO: M501
PROJ NO: 017384
AGENCY REVIEW ID: 17-1742-01A