

16 15 14 13 12 11 10 9 8 7 6 5 4 3 2 1

J  
I  
H  
G  
F  
E  
D  
C  
B  
A

- A. FIELD VERIFY ALL OPENINGS AND HEIGHTS PRIOR TO FABRICATION AND INSTALLATION.
- B. ENTIRE STAIR MUST BE ADA AND CODE COMPLIANT.
- C. ALL RISERS TO BE UNIFORM HEIGHT - 7" MAXIMUM.
- D. ALL TREADS TO BE EQUAL DEPTH - 11" MINIMUM.
- E. PROVIDE 1/2" MAXIMUM RADIUS AT ALL STAIR NOSINGS, NOSINGS MUST BE SLIP-RESISTANT.
- F. PROVIDE CONCEALED, FIRE TREATED, MOISTURE RESISTANT WOOD BLOCKING FOR HANDRAIL CONNECTIONS AT PARTITION WALLS.
- G. REFERENCE STRUCTURAL DRAWINGS FOR SLAB EDGES, STEEL CONNECTIONS AND ANCHORAGE.
- H. GRIND ALL WELDS AND BLEND ALL EDGES SMOOTH.
- I. ALL STEEL MUST BE PRIMED AND READY FOR PAINT FINISH.
- J. SUBMIT SHOP DRAWINGS FOR REVIEW PRIOR TO FABRICATION AND INSTALLATION.
- K. ALL RISERS SHALL BE CLOSED.
- L. COORDINATE ELEVATOR REQUIREMENTS INCLUDING PIT SIZES, ROUGH OPENINGS, STAIR OPENINGS, ETC. WITH MANUFACTURER.
- M. FIELD VERIFY SLAB OPENINGS PRIOR TO ORDER AND INSTALLATION.
- N. PROVIDE DRAINAGE AND VENTS AS REQUIRED.
- O. COORDINATE ALL REQUIREMENTS WITH STRUCTURAL AND MEP.
- P. SUBMIT MANUFACTURER'S AVAILABLE CAB FINISH PACKAGE CHART FOR ARCHITECT'S SELECTION.
- Q. PROVIDE WATERPROOFING AND DAMPROOFING AS REQUIRED FOR WALLS AND FLOORS AT CONCRETE WALLS AND FOUNDATIONS BELOW GRADE.
- R. PROVIDE KEY ACCESS BOX AT ELEVATOR AS REQUIRED BY AHJ. COORDINATE LOCATION WITH ARCHITECT.

#	NUMBER	DESCRIPTION
	CPT-2	CARPET TILE - INTERFACE, MONOCHROME, BLUE 101841
	MTL-3	GALVANIZED STEEL STRUCTURE, RE. STRUCTURAL
	MTL-4	ALUMINUM STAIR TREADS & LANDING - HEBEL, PROOF GRATING
	WB-1	RUBBER WALL BASE
	WB-3	MUSEUM BASE - REGLET REVEAL AT FLOOR - PAINTED FINISH, POPLAR WALL BASE

FINISH KEYOTES 5H VERTICAL CIRCULATION GENERAL NOTES 1H

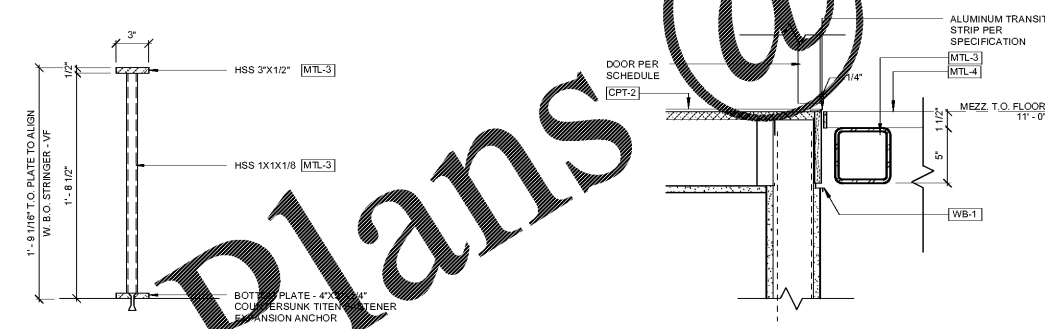

ENLARGED DETAIL @ RAIL BELOW STAIR  
1 1/2" = 1'-0"

13A

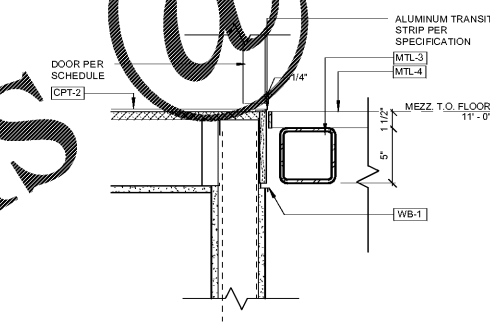

EDGE DETAIL @ ELEVATOR LANDING  
1 1/2" = 1'-0"

9A

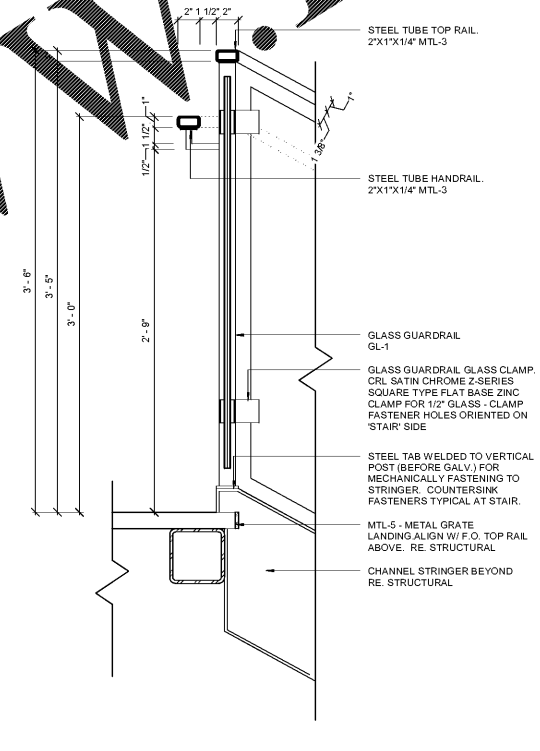

SECTION DETAIL @ GUARDRAIL  
1 1/2" = 1'-0"

5A

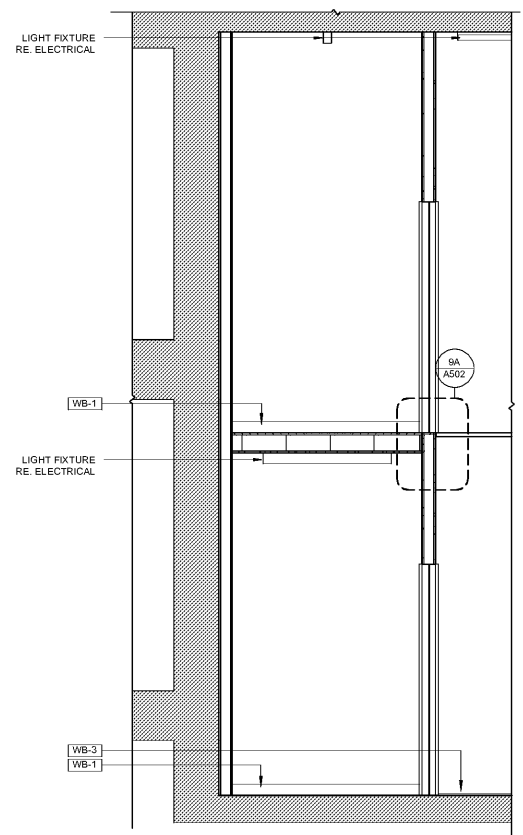

SECTION @ STAIR LANDING TRANSITION  
3/8" = 1'-0"

1A

**KEM STUDIO**  
1515 GENESSEE ST SUITE 11 KANSAS CITY MO 64102  
816 756 1808 f 816 756 1828

RELATED DOCUMENTS: This Drawing may be part of an integrated set of Construction Documents, including the executed Agreement, the General and Supplemental Conditions of the Contract, Division-01 "General Requirements", and applicable technical Specification Sections. The Contract Documents are complementary; what is required by one is as binding as if required by all. Other documents affecting the Work may include Geotechnical recommendations, Manufacturer's Product Data and installation requirements, Shop Drawings and Coordination Drawings. Failure to review applicable documents does not reduce the obligation to provide complete and operational building components.

THE INTENT OF THE CONTRACT DOCUMENTS is to include all items necessary for completion of the construction Work indicated. Except as otherwise indicated, provide (furnish and install) all products, materials, equipment, options, items or accessories necessary for proper operation and use, in accordance with product manufacturer's requirements, and comply with applicable laws, codes and ordinances of Authorities Having Jurisdiction (AHJ).

VERIFY EXISTING CONDITIONS AND DIMENSIONS prior to construction. Calculate and measure dimensions - DO NOT SCALE THE DRAWINGS unless so directed by the Architect. Dimensions indicated are to the face of a material unless otherwise indicated. Application of a material or equipment item to Work installed by others constitutes acceptance of that Work, and assumption of responsibility for subsequent satisfactory installation.

THIS DRAWING WAS PREPARED under the Architect's supervision, and is an "Instrument of Service" in limited liability for use on this Project. The Architect's Services are performed solely in the interest of the Architect's Client - no obligation is assumed by the Architect for the benefit of any other entity involved in the Construction Work. The information, ideas and designs indicated - including the overall form, arrangement and composition of spaces or building elements - constitutes the original, confidential, and unpublished Work and property of the Architect. Possession of this Drawing confers no right or license to disclose to others the subject matter contained herein for any but authorized purposes. Unauthorized use, reproduction or distribution - in whole or in part - is strictly prohibited. Copyright © 2018 by KEM STUDIO.

PORT KC OFFICES

1000 BERKLEY PARKWAY - SPACE E177  
KANSAS CITY, MO 64106

PROJECT NUMBER: A1718

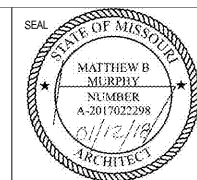

ISSUED FOR:  
P.R. #01 - SHELL OPENINGS 01.05.2018  
PERMIT 01.12.2018

VERTICAL CIRCULATION -  
DETAILS

A502