

#	NUMBER	DESCRIPTION	
1J	MTL-1	POWDER COATED STEEL - WHITE	
	WB-3	MUSEUM BASE - REVEAL AT FLOOR - PAINTED FINISH. POPLAR WALL BASE	
	WD-1	WOOD PANELING - ELMWOOD, WHITE OAK TRADITIONAL, CLEAN LINEN, WIDTH - 4", FINISH - V.I.F., JOINTS - 3/4" REVEAL BETWEEN PLANKS = 1/4" RE. DETAIL, (LENGTHS - NO CUT PLANKS. ROOM #110 WIDTH = 11'-0", ROOM #115 WIDTH = 9'-10" V.I.F.)	
1J	WD-2	WOOD TOP - ELMWOOD, WHITE OAK TRADITIONAL, CLEAN LINEN, WIDTH - 4", THICKNESS - 1-1/2", LENGTHS - NO CUT PLANKS. BASED EDGE ONLY. LOCATION: RECEPTION DESK	
	KEYNOTES- INTERIOR ELEVATIONS		

E-#	NUMBER	DESCRIPTION	
1I	E10	COPIER BY OWNER	
	EQUIPMENT KEYNOTES		

- A. GRIND ALL WELDS AND BLEND ALL EDGES SMOOTH.
- B. SUBMIT SHOP DRAWINGS FOR REVIEW PRIOR TO FABRICATION AND INSTALLATION.
- C. FIELD VERIFY EXISTING CONDITIONS TO ENSURE PROPER FIT AND WORK. NOTIFY ARCHITECT OF CONFLICTS IN REGARDS TO ALIGNMENTS PRIOR TO INSTALLATION.
- D. COORDINATE FINAL PLACEMENT OF LOGOS WITH ARCHITECT PRIOR TO INSTALLATION. PROVIDE CONCEALED PLYWOOD BACKING FOR MOUNTING.
- E. POWDER COAT RECEPTION DESK STEEL FRAME. COLOR PER ARCHITECT.
- F. NO EXPOSED FASTENERS ON INTERIOR FINISHES.
- G. REFERENCE FINISH SCHEDULE FOR FINISHES.

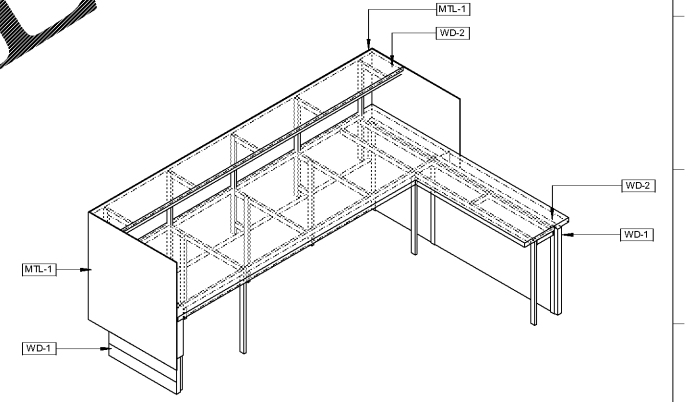

INTERIOR ELEVATION - RECEPTION - E  
3/8" = 1'-0" **13G**

INTERIOR ELEVATION - RECEPTION - N  
3/8" = 1'-0" **9G**

RECEPTION DESK GENERAL NOTES **5G**

RECEPTION DESK - 3D AXONOMETRIC **1F**

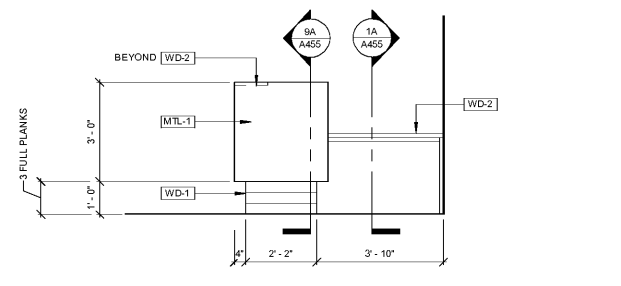

INTERIOR ELEVATION - RECEPTION - W  
3/8" = 1'-0" **13D**

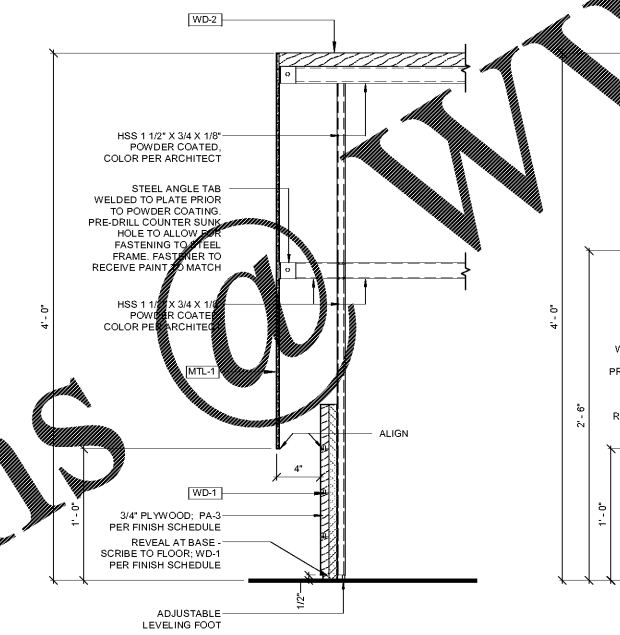

SECTION DETAIL @ RECEPTION DESK 02  
1 1/2" = 1'-0" **9A**

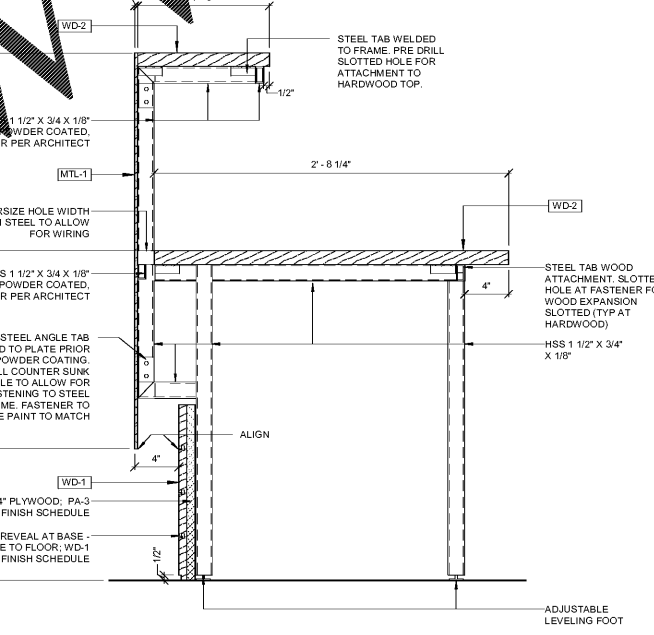

SECTION THRU RECEPTION DESK  
1 1/2" = 1'-0" **5A**

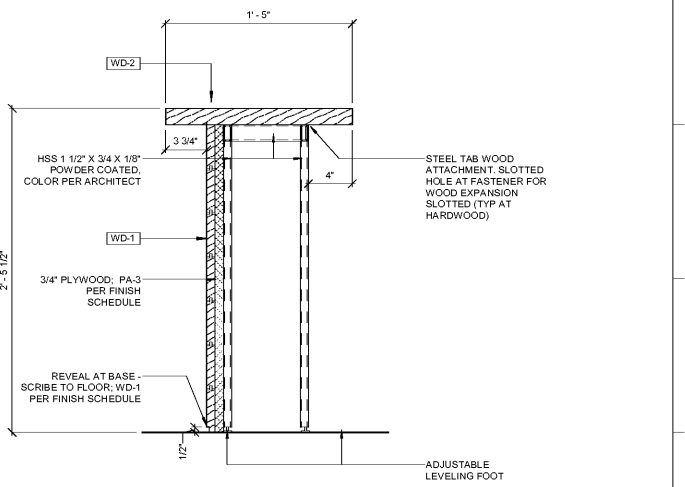

SECTION DETAIL @ RECEPTION DESK 01  
1 1/2" = 1'-0" **1A**

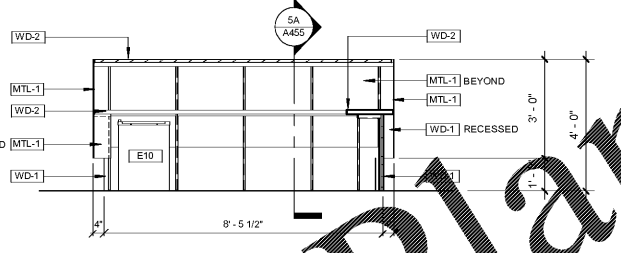

INTERIOR ELEVATION - RECEPTION - E  
3/8" = 1'-0" **13A**

**KEM STUDIO**  
1515 GENESSEE ST SUITE 11 KANSAS CITY MO 64102  
816 756 1808 f 816 756 1828  
kemstudio.com

**RELATED DOCUMENTS:** This Drawing may be part of an integrated set of Construction Documents, including the executed Agreement, the General and Supplemental Conditions of the Contract, Division-01 "General Requirements", and applicable "technical" Specification Sections. The Contract Documents are complementary; what is required by one is as binding as if required by all. Other documents affecting the Work may include Geotechnical recommendations, Manufacturer's Product Data and installation requirements, Shop Drawings and Coordination Drawings. Failure to review applicable documents does not reduce the obligation to provide complete and operation building components.

**THE INTENT OF THE CONTRACT DOCUMENTS** is to include all items necessary for completion of the construction Work indicated. Except as otherwise indicated, provide (furnish and install) all products, materials, equipment, options, items or accessories necessary for proper operation and use, in accordance with product manufacturer's requirements, and comply with applicable laws, codes and ordinances of Authorities Having Jurisdiction (AHJ).

**VERIFY EXISTING CONDITIONS AND DIMENSIONS** prior to construction. Calculate and measure dimensions - DO NOT SCALE THE DRAWINGS unless as directed by the Architect. Dimensions indicated are to the face of a material unless otherwise indicated. Application of a material or equipment item to Work installed by others constitutes acceptance of that Work, and assumption of responsibility for subsequent satisfactory installation.

**THIS DRAWING WAS PREPARED** under the Architect's supervision, and is an "Instrument of Service" in limited solely for use on this Project. The Architect's Services are performed solely in the interest of the Architect's Client; no obligation is assumed by the Architect for the benefit of any other entity involved in the Construction Work. The information, ideas and designs indicated - including the overall form, arrangement and composition of spaces or building elements - constitutes the original, confidential, and unpublished Work and property of the Architect. Possession of this Drawing confers no right or license to disclose to others the subject matter contained herein for any but authorized purposes. Unauthorized use, reproduction or distribution - in whole or in part - is strictly prohibited. Copyright © 2018 by KEM STUDIO.

**PORT KC OFFICES**  
1000 BERKLEY PARKWAY - SPACE E177  
KANSAS CITY, MO 64106  
PROJECT NUMBER: A1718



ISSUED FOR:

P.R. #01 - SHELL OPENINGS	01.05.2018
PERMIT	01.12.2018

**INTERIOR DETAILS - RECEPTION DESK**  
**A455**