

(4) BOLT BASE PLATE

(4)(6) BOLT BASE PLATE AT BRACE

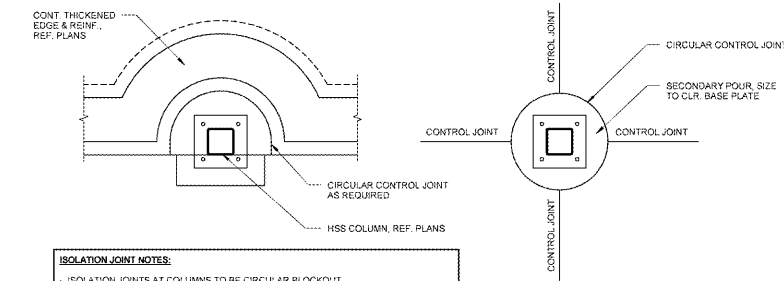

ISOLATION JOINT NOTES:
 - ISOLATION JOINTS AT COLUMNS TO BE CIRCULAR BLOCKOUT.
 - SECONDARY POUR AT LEAVE OUTS TO BE SIZED TO CLR. BASE PLATE AND BRACE WHERE BRACE OCCURS.

(2) GENERAL ISOLATION JOINT INFORMATION

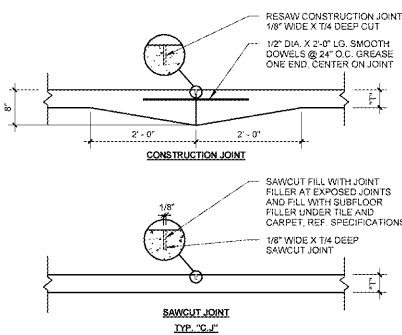

SLAB JOINT NOTES:
 - REF. PLAN FOR SLAB THICKNESS "T", REINFORCING AND SUBBASE.
 - CONTROL JOINTS TO BE EITHER A SAWCUT OR CONSTRUCTION JOINT.
 - SAWCUT JOINT SHALL BE 1/8" WIDE X 1/4" DEEP CUT MADE WITHIN 24 HRS. OF POUR. WWT SHALL BE CONTINUOUS @ ALL C.I.S. U.O.N. ON PLANS.
 - DIAMOND DOWELS MAY BE USED IN LIEU OF SMOOTH DOWELS AT SPACING INDICATED FOR CONSTRUCTION JOINTS.
 - DOWELS MUST BE LEVEL AND SQUARE WITH JOINTS.

(3) GENERAL CONSTRUCTION JOINT INFORMATION

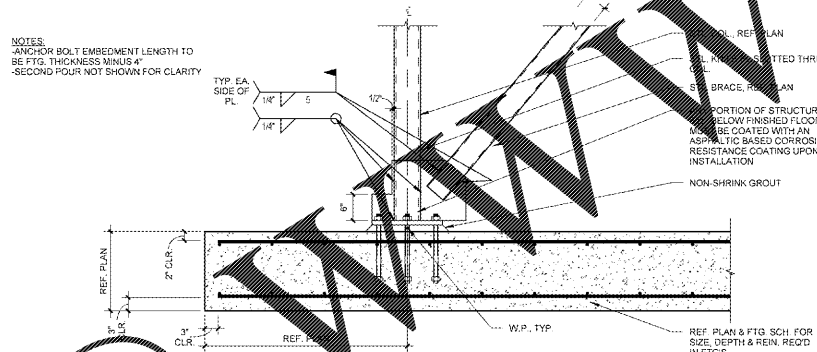

(9) FOUNDATION DETAIL

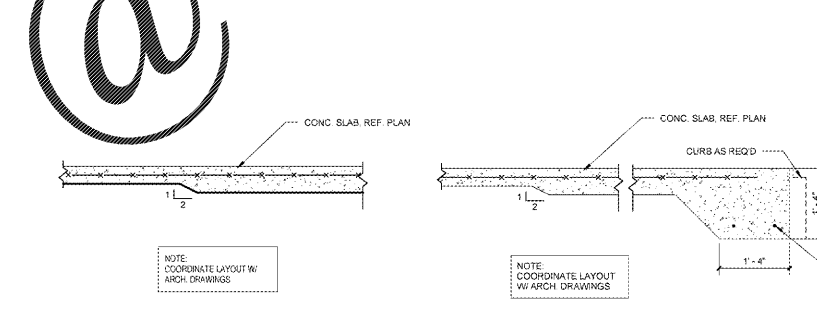

(13) FOUNDATION DETAIL

(14) FOUNDATION DETAIL

(4) FOUNDATION DETAIL

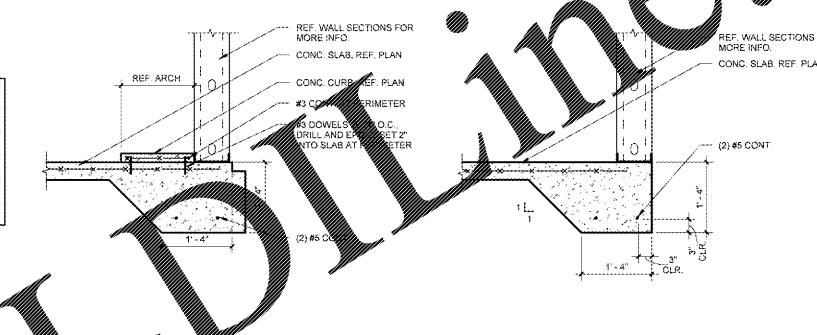

(6) FOUNDATION DETAIL

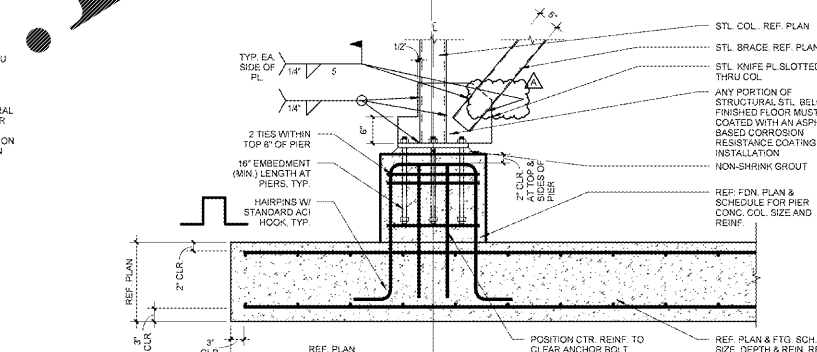

(10) FOUNDATION DETAIL

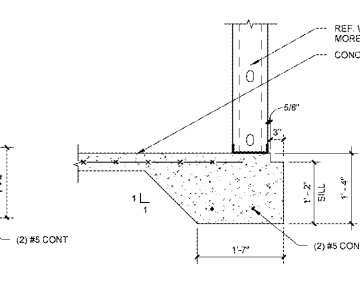

(15) THICKENED EDGE - WITH CURB

(5) FOUNDATION DETAIL

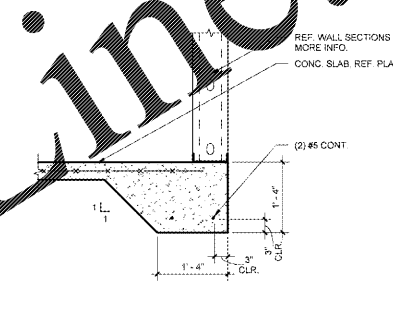

(7) THICKENED EDGE DETAIL

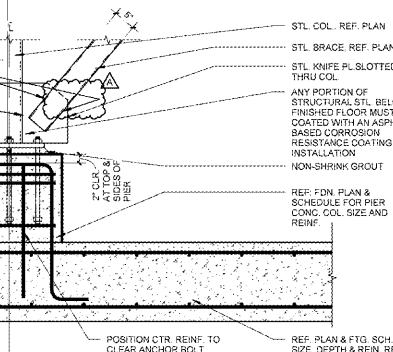

(16) CURB AT COLUMN

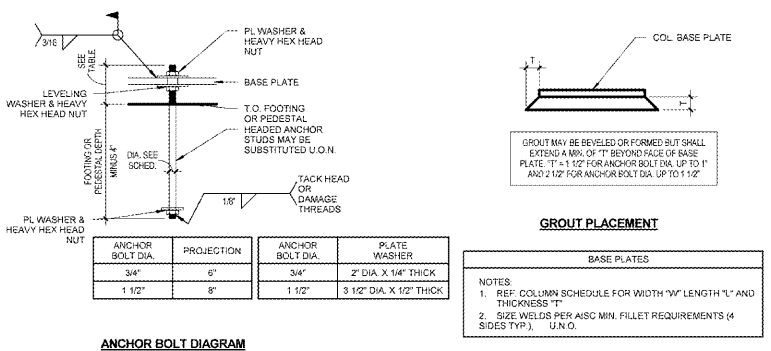

ANCHOR BOLT DIAGRAM

BASE PLATES

NOTES:
 1. REF. COLUMN SCHEDULE FOR WIDTH "W", LENGTH "L" AND THICKNESS "T".
 2. SIZE WELDS PER AISC MIN. FILLET REQUIREMENTS (4 SIDES TYP.). U.O.N.

(1) GENERAL BASE PLATE AND ANCHOR BOLT INFORMATION

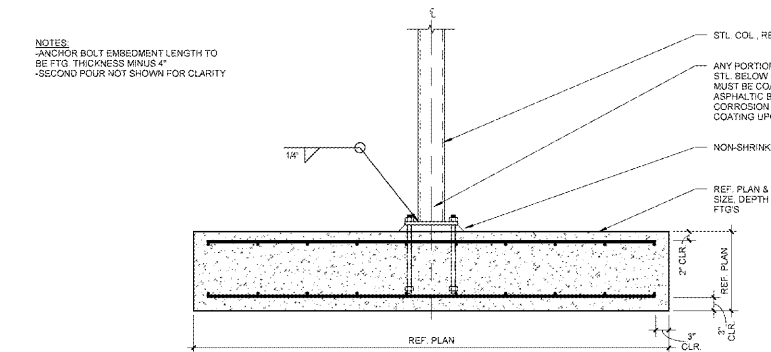

(8) FOUNDATION DETAIL

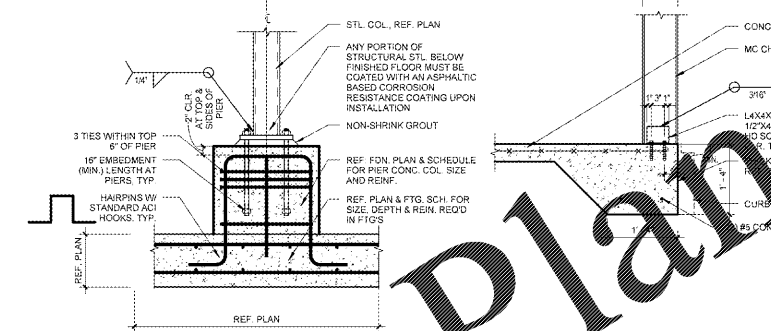

(11) FOUNDATION DETAIL

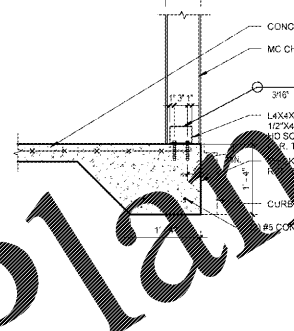

(12) FOUNDATION DETAIL

(17) INTERIOR FOUNDATION DETAIL

(18) PIER #2 SECTION

(18) PIER #2 SECTION

(19) PIER #2 ISO

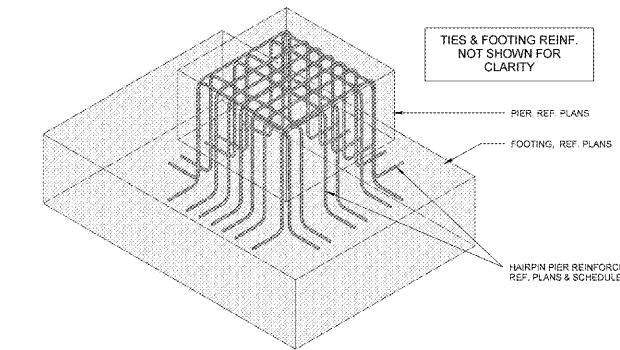

(19) PIER #2 ISO

Order Plans

1925 Prospect Ave.
 Orlando, FL 32814
 P (407) 661-9100
 F (407) 661-9101
 www.cpe.com
 Cahaci & Retamians
 Architects Engineers

CLIENT NAME
WAWA
 260 WEST BALTIMORE PIKE
 WAWA, PENNSYLVANIA 19083

PROJECT NAME
WAWA F85FB 2017.01 STORE #5294-CNY
 26008 U.S. 19 NORTH
 CLEARWATER, FL 33761

No.	Description	Date
1	PRELIMINARY	01/17/2017
2	REVISION	07/26/2017
3	PRE-BID REVIEW SET	07/26/2017
4	BID SET	08/08/2017