

**GENERAL NOTES**

- SOIL TREATMENT FOR TERMITE CONTROL SHALL BE PER SPECIFICATIONS
- REFER TO FLORIDA PRODUCT APPROVAL SCHEDULE ON COVER SHEET FOR APPLICABLE BLDG. FRONT SPEC. IMPACT GLASS MAY BE REQUIRED.
- SEE FLOOR AND CEILING SCHEDULES FOR FINISH CONDITIONS AT WALL, TILE IN THE FOOD SERVICE AREA AND RESTROOM.

**LARGE MISSILE IMPACT RATED STOREFRONT AND GLAZING ARE REQUIRED FOR THIS LOCATION. REFER TO SPECS.**

**LEGEND**

- 8" MTL STUDS W/ R-30 BATT INSULATION AND EXT. VENT.
- NOTE: BY REF. CO.
- 4" DIA. BOLLARD SUPPLIED BY WALL SUPPLIER TO INSTALL CO2 TANK ALARM AND FILL BOX.
- NOTE: INSTALL PRE-PANDED PLYWOOD FROM FLOOR TO CEILING IN ELECTRICAL ROOM. ALL WALLS COLOR: BENHANN MOORE AF-700 (STORM GRAY).
- NOTE: ALL WALLS TO GO TO UNDERSIDE OF ROCK BECK. UNLESS OTHERWISE NOTED, PROVIDE SLOTTED TRACK AT CEILING.

**EQUIPMENT BLOCKING NOTES**

#	ITEM	BLK. MATL.	LOCATION AND REMARKS
1	SMELLING BOWL COMP. SINK	1/2" PLYWOOD	IN LINE OF DWL. SEE ELEVATION
2	MOP HOLDER	2" X 6"	5'-0"
3	HAND DRYER	2" X 6"	3'-3" AND 4'-0"
4	HAND WASH SINK	2" X 6"	5'-0"
5	URINAL	ALUM. MANUF.	2'-0" DIA.
6	GRAB BARS	2" X 4"	2'-10 1/2" & VERTICAL
7	POWER WASH SHELF	2" X 6"	6'-6 1/2"
8	TRASH BAG HOLDER	2" X 6"	2'-0" AND 4'-0"
9	TOILET PAPER DISP.	ALUM. MANUF.	AS PER MANUF.
10	TOILET SEAT	2" X 12"	3'-10"
11	TOILET BRUSHES	2" X 12"	3'-10"
12	OFFICE SECURITY SHELF	2" X 10"	4'-0" SEE DETAIL ON B349
13	LOCKERS	2" X 10"	19'-0"
14	WEEKEND KIOSK	2" X 6"	7'-0"
15	SOURCE TASK SHELF	2" X 6"	7'-0"
16	WATER FOUNTAIN LOW	2" X 6"	2'-6"
17	WATER FOUNTAIN HIGH	2" X 6"	3'-0"
18	BREW COFFEE STATION	2" X 6"	11'-0" SEE SHEET G1
19	DATA SIGN COMPRESS	2" X 6"	8'-0" SEE DETAIL 2048.1
20	FIRE EXTINGUISHER	2" X 6"	3'-0" SEE DETAIL 446
21	BREW COOLER SIDE CABINETS	2" X 6"	10'-0" SEE SHEET G1
22	COFFEE AREA CURBY	2" X 6"	AS PER DETAIL 2048.1
23	SELF SERVICE DRINK AREA	1/2" PLYWOOD	SHEATH WALL FLOOR TO CEILING. SEE NOTE 4 AND DETAIL 1301 & B48.1
24	PULL SERVICE CURBY	2" X 8" & 2" X 10"	SEE DETAIL 2048.1
25	COFFEE AREA CURBY	2" X 10"	SEE DETAIL 2048.1
26	BOOSE LOGO SIGN	2" X 4"	9'-0" & 10'-0" SEE ELEVATION
27	3 COMPARTMENT SINK	2" X 12"	7'-11" SEE ELEVATION
28	TRASH RECEPTACLE	2" X 6"	3'-0"
29	BAR COUNTER	2" X 12"	AS PER DETAIL 1064

**DOOR NOTES**

**DOOR FRAMES:**  
 ALL DOOR FRAMES, INTERIOR AND EXTERIOR TO BE FULLY WELDED. NO KNOCK-DOWN FRAMES. WOOD BLOCKING AT JAMBS AND HEAD OF ALL INTERIOR DOORS AS REQUIRED.

- DOOR #S SHOWN IN DOOR SCHEDULE ARE TYPICAL FOR WAWA STORES. VERIFY QUANTITIES AND WHICH DOORS ARE REQUIRED AS INDICATED IN FLOOR PLAN.
- SEE STOREFRONT MANUFACTURER SPECIFICATIONS FOR VESTIBULE DOORS AND HARDWARE. DOORS ARE TO BE KEYPAD ALIKE WITH THUMB LATCH AND CLOSERS AT ALL DOORS.
- ALL EXTERIOR HOLLOW METAL DOORS SHALL BE INSULATED DOORS.
- RUN CONTINUOUS BEAD OF CLEAR SILICONE CAULK AROUND ALL DOOR FRAMES.
- EXIT DOOR LOCKS, IF PROVIDED ON EGRESS DOORS, SHALL NOT REQUIRE THE USE OF A KEY OR OTHER KNOWLEDGE OR EFFORT FOR OPERATION FROM THE EGRESS SIDE IN ACCORDANCE TO SECTION 14.5.3.3 OF FIFC AND SECTION 1008.1.9 OF IBC UNLESS SPECIFICALLY ALLOWED BY CODE.
- A LATCH OR OTHER FASTENING DEVICE ON A EGRESS DOOR SHALL BE PROVIDED WITH A KNOB, HANDLE, PANIC BAR, OR OTHER SIMPLE TYPE OF RELEASING DEVICE HAVING AN OBVIOUS METHOD OF OPERATION UNDER ALL LIGHTING CONDITIONS. DOORS SHALL BE OPERABLE WITH NO MORE THAN ONE RELEASING OPERATION PER FIFC 14.5.2.10.
- REFER TO HARDWARE SCHEDULES IN THE SPECIFICATION MANUAL.
- THRESHOLD 'A' NOT TO EXCEED 1/2" HIGH.
- DOOR IC REQUIRES HOLE IN SLAB FOR BOLT.
- VISION PANEL DIMENSIONS CORRESPOND TO VISIBLE LIGHT DIMENSIONS. CONTRACTOR TO COORDINATE REQUIRED GLASS SIZE AND ROUGH OPENING WITH DOOR MANUFACTURER.

**DOOR SCHEDULE**

#	W	H	TH	TYPE	MATL.	FRM	HW	SET	COMMENTS	PUSH	PULL
AP4	2'-6"	2'-0"	-	GLASS	GLASS	ALUM.	ALUM.	A	W/STORMING		
EA	4'-0"	7'-0"	0'-1.34"	C	HM	HM	A	HW 10	4" X 20" LAMINATED GLASS VISION PANEL. SEE 25 & 26K7 FOR HEAD & JAMB.	PANIC BAR	36" X 48"
EL	3'-0"	6'-0"	0'-1.34"	E	HM	HM	A	HW 13	4" X 20" GLASS VISION PANEL. 24" X 24" LOCKER. PUSH/SHUTTER LOCK ON PULL SIDE. SEE DETAIL 2249.	PANIC BAR	
H	3'-0"	7'-0"	0'-1.34"	BF	HM	HM	B	HW 6	ONE LEAF W/ 12" X 18" LOWER (DOUBLE DOOR). SEE 25 & 26K7 FOR HEAD & JAMB.		
OF	3'-0"	6'-0"	0'-1.34"	C	HM	HM	A	HW 12	4" X 20" ONE WAY VISION PANEL. UNDERCUT P. SEE DETAIL 2249.	LOCKSET	16" X 34" 16" X 35"
PI	3'-0"	6'-0"	0'-1.34"	B	HM	HM	A	HW 7	UNDERCUT DOOR P. SEE DETAIL 2249.	24" X 24"	16" X 34" 16" X 35"
R	3'-0"	6'-0"	0'-2"	REF	-	-	-	-	BY REFRIGERATION COMPANY.		
R1	3'-0"	6'-0"	0'-4"	REF	-	-	-	-	BY REFRIGERATION COMPANY.		
R2	4'-0"	6'-0"	0'-2"	REF	-	-	-	-	BY REFRIGERATION COMPANY (DOUBLE DOORS).		
R3	3'-0"	6'-0"	0'-2"	REF	-	-	-	-	BY REFRIGERATION COMPANY (GLAZED).		
T1	3'-0"	6'-0"	0'-1.34"	C	HM	HM	A	HW 11	4" X 20" GLASS VISION PANEL. SEE DETAIL 2249.	PASSAGE SET	16" X 34" 16" X 35"
T5	3'-0"	7'-0"	0'-1.34"	C	HM	HM	B	HW 5.3	4" X 20" LAMINATED GLASS VISION PANEL. SEE 25 & 26K7 FOR HEAD & JAMB.	LOCKSET	36" X 41"
TH	3'-0"	4'-0"	0'-2.18"	D	ALUM.	ALUM.	A	HW 19	TOWER ACCESS: W/STORM KIT, SERIES INSULATED ACCESS PANEL. PROVIDE IRON SHIELD. SEE 30K.		
V1	3'-0"	7'-0"	0'-1.34"	A	ALUM.	ALUM.	C	-	NO HOLD OPENS (DOUBLE DOOR).	PUSH BAR	
V2	3'-0"	7'-0"	0'-1.34"	A	ALUM.	ALUM.	C	-	NO HOLD OPENS (DOUBLE DOOR).	PUSH BAR	
V3	3'-0"	7'-0"	0'-1.34"	A1	ALUM.	ALUM.	C	-	NO HOLD OPENS. PUSH ONLY.	PUSH BAR	
W	3'-0"	6'-0"	0'-1.34"	C	HM	HM	A	HW 3	4" X 20" GLASS VISION PANEL. SEE DETAIL 2249.	36" X 41"	16" X 34" 16" X 35"
W1	3'-0"	6'-0"	0'-1.34"	C	HM	HM	A	HW 3.1	DOUBLE ACTING W/ 4" X 20" GLASS VISION PANEL. SEE DETAIL 2249.	36" X 41"	16" X 34" 16" X 35"
W2	3'-0"	6'-0"	0'-1.34"	C	HM	HM	A	HW 3.2	4" X 20" ONE WAY VISION GLASS. THUMB LATCH. SEE DETAIL 2249.	36" X 41"	16" X 34" 16" X 35"
W5	3'-0"	6'-0"	0'-1.34"	C	HM	HM	A	HW 3.5	ONE WAY 4" X 20" VISION PANEL. PROVIDE 1/2" WIDE JAMB EXTENSION ON THE RETAIL SIDE. SEE DETAIL 2249.	36" X 41"	16" X 34" 16" X 35"

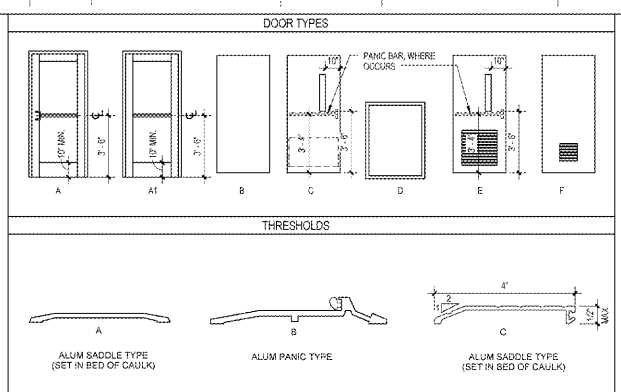

**DOOR SCHEDULE**

#	W	H	TH	TYPE	MATL.	FRM	HW	SET	COMMENTS	PUSH	PULL
AP4	2'-6"	2'-0"	-	GLASS	GLASS	ALUM.	ALUM.	A	W/STORMING		
EA	4'-0"	7'-0"	0'-1.34"	C	HM	HM	A	HW 10	4" X 20" LAMINATED GLASS VISION PANEL. SEE 25 & 26K7 FOR HEAD & JAMB.	PANIC BAR	36" X 48"
EL	3'-0"	6'-0"	0'-1.34"	E	HM	HM	A	HW 13	4" X 20" GLASS VISION PANEL. 24" X 24" LOCKER. PUSH/SHUTTER LOCK ON PULL SIDE. SEE DETAIL 2249.	PANIC BAR	
H	3'-0"	7'-0"	0'-1.34"	BF	HM	HM	B	HW 6	ONE LEAF W/ 12" X 18" LOWER (DOUBLE DOOR). SEE 25 & 26K7 FOR HEAD & JAMB.		
OF	3'-0"	6'-0"	0'-1.34"	C	HM	HM	A	HW 12	4" X 20" ONE WAY VISION PANEL. UNDERCUT P. SEE DETAIL 2249.	LOCKSET	16" X 34" 16" X 35"
PI	3'-0"	6'-0"	0'-1.34"	B	HM	HM	A	HW 7	UNDERCUT DOOR P. SEE DETAIL 2249.	24" X 24"	16" X 34" 16" X 35"
R	3'-0"	6'-0"	0'-2"	REF	-	-	-	-	BY REFRIGERATION COMPANY.		
R1	3'-0"	6'-0"	0'-4"	REF	-	-	-	-	BY REFRIGERATION COMPANY.		
R2	4'-0"	6'-0"	0'-2"	REF	-	-	-	-	BY REFRIGERATION COMPANY (DOUBLE DOORS).		
R3	3'-0"	6'-0"	0'-2"	REF	-	-	-	-	BY REFRIGERATION COMPANY (GLAZED).		
T1	3'-0"	6'-0"	0'-1.34"	C	HM	HM	A	HW 11	4" X 20" GLASS VISION PANEL. SEE DETAIL 2249.	PASSAGE SET	16" X 34" 16" X 35"
T5	3'-0"	7'-0"	0'-1.34"	C	HM	HM	B	HW 5.3	4" X 20" LAMINATED GLASS VISION PANEL. SEE 25 & 26K7 FOR HEAD & JAMB.	LOCKSET	36" X 41"
TH	3'-0"	4'-0"	0'-2.18"	D	ALUM.	ALUM.	A	HW 19	TOWER ACCESS: W/STORM KIT, SERIES INSULATED ACCESS PANEL. PROVIDE IRON SHIELD. SEE 30K.		
V1	3'-0"	7'-0"	0'-1.34"	A	ALUM.	ALUM.	C	-	NO HOLD OPENS (DOUBLE DOOR).	PUSH BAR	
V2	3'-0"	7'-0"	0'-1.34"	A	ALUM.	ALUM.	C	-	NO HOLD OPENS (DOUBLE DOOR).	PUSH BAR	
V3	3'-0"	7'-0"	0'-1.34"	A1	ALUM.	ALUM.	C	-	NO HOLD OPENS. PUSH ONLY.	PUSH BAR	
W	3'-0"	6'-0"	0'-1.34"	C	HM	HM	A	HW 3	4" X 20" GLASS VISION PANEL. SEE DETAIL 2249.	36" X 41"	16" X 34" 16" X 35"
W1	3'-0"	6'-0"	0'-1.34"	C	HM	HM	A	HW 3.1	DOUBLE ACTING W/ 4" X 20" GLASS VISION PANEL. SEE DETAIL 2249.	36" X 41"	16" X 34" 16" X 35"
W2	3'-0"	6'-0"	0'-1.34"	C	HM	HM	A	HW 3.2	4" X 20" ONE WAY VISION GLASS. THUMB LATCH. SEE DETAIL 2249.	36" X 41"	16" X 34" 16" X 35"
W5	3'-0"	6'-0"	0'-1.34"	C	HM	HM	A	HW 3.5	ONE WAY 4" X 20" VISION PANEL. PROVIDE 1/2" WIDE JAMB EXTENSION ON THE RETAIL SIDE. SEE DETAIL 2249.	36" X 41"	16" X 34" 16" X 35"

**Order Plans**

1925 Prospect Ave.  
Orlando, FL 32814  
P (407) 661-9100  
F (407) 661-9101  
www.cwb.com

**Cuba & Ret**  
Architects Engineers

**CLIENT NAME**  
WAWA  
260 WEST BALTIMORE PIKE  
WAWA, PENNSYLVANIA 19083

**PROJECT NAME**  
WAWA F85FB 2017.01 STORE #5294-CNY  
2600R US 19 NORTH  
CLEARWATER, FL 33761

**SHEET TITLE**  
FLOOR PLAN

**Revision Schedule**

No.	Description	Date
1	PRELIMINARY SET	01/17/2017
2	FILED FOR REVIEW SET	07/28/2017
3	BID SET	09/04/2017

**PROJECT NO.** 2016022  
**DATE** 01/03/2017  
**DESIGNER** [Signature]  
**DATE** [Signature]

**A1**