

PLUMBING FIXTURE SCHEDULE (LOW FLOW ELECTRONIC FIXTURES)

MARK	DESCRIPTION	MANUFACTURER, MODEL NUMBER	FITTINGS/ACCESSORIES	REMARKS	MINIMUM FIXTURE CONNECTIONS			
					CW	HW	WASTE	VENT
P-1A	WATER CLOSET ELONGATED, WALL MTD., FLUSH VALVE, ADA	TOTO USA CT708E	FLUSH VALVE: TOTO TET1LA32#CP, SELF-POWERED; SEAT: TOTO SC534, STAINLESS STEEL HINGE, NUTS, AND WASHER.	1.28 GPF, ELONGATED, WALL MOUNTED CARRIER J.R. SMITH 0208 HORIZONTAL; J.R. SMITH 0440 VERTICAL; 17" MINIMUM SEAT HEIGHT, ADA HANDLE INSTALLED ON WIDE SIDE	1"	---	3" U.N.O.	2"
P-3A	LAVATORY, WALLHUNG, ADA	KOHLER HUDSON K-2805-0	FAUCET: TOTO TEL155-D10ET, ECOPOWER, SELF-GENERATING HYDROPOWERED, TMV; PROVIDE WITH GRID DRAIN, TAILPIECE AND TRUEBRO "LAV-GUARD"	19"x17", WALL MOUNTED SINK W/ OVERFLOW, SINGLE HOLE, SENSOR OPERATED FAUCET, 0.5 GPM AERATOR, ADA, K-8998 P-TRAP, LF170 SUPPLY W/ FLEXIBLE RISER.	1/2"	1/2"	1-1/4"	1-1/4"
P-6	SINK SINGLE COMPARTMENT	JUST SL-ADA-1921-A-GR	FAUCET: ELKAY LK3001CR, 1.5 GPM, BASKET STRAINER WITH OFFSET TAILPIECE & TRUEBRO "LAV-GUARD"	19"x21"x6-1/2"D, 304 STAINLESS STEEL, SELF-RIMMING, 3 HOLES, 4" CENTERS, SINGLE LEVER FAUCET WITH SIDE SPRAY, LF170 SUPPLY W/ FLEXIBLE RISER.	1/2"	1/2"	1-1/2"	1-1/2"
FD-1	FLOOR DRAIN	J.R. SMITH 2005	CAST IRON BODY, FLASHING COLLAR, 6" SQUARE NICKEL BRONZE ADJUSTABLE STRAINER.	FINISHED AREAS, PROVIDE WITH PROSET TRAP GUARD DEVICE	---	---	---	---

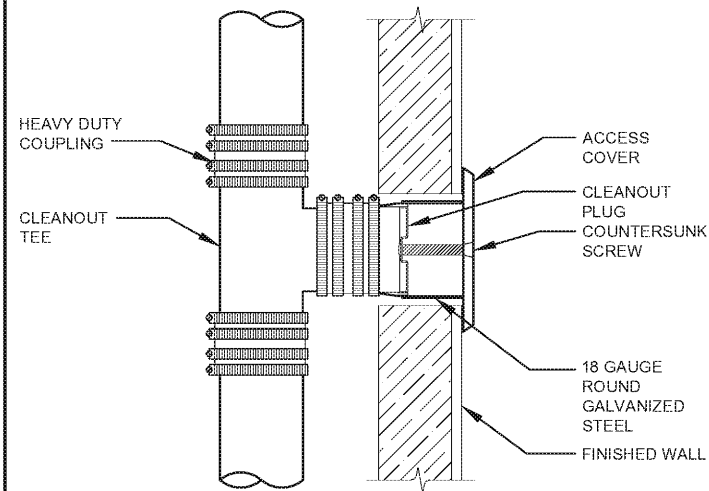

4 CAST IRON WALL CLEANOUT DETAIL
SCALE: NO SCALE

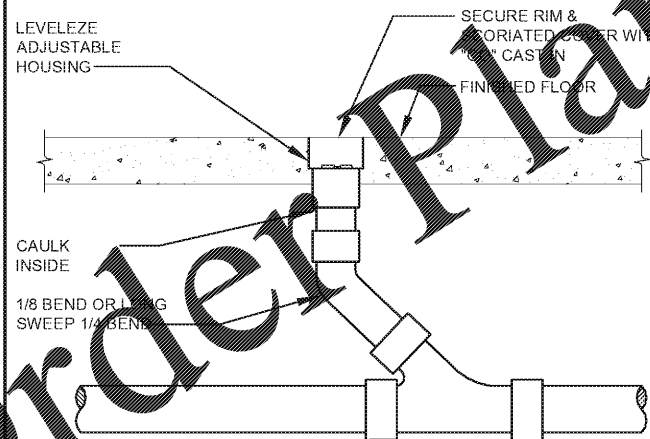

3 FLOOR CLEANOUT DETAIL
SCALE: NO SCALE

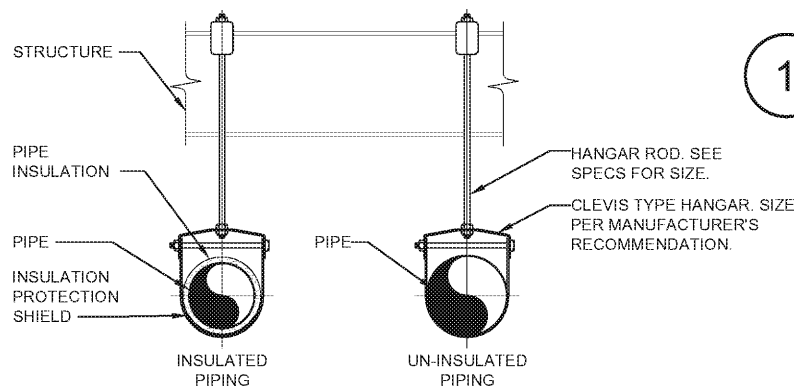

2 PIPE HANGAR DETAIL
SCALE: NO SCALE

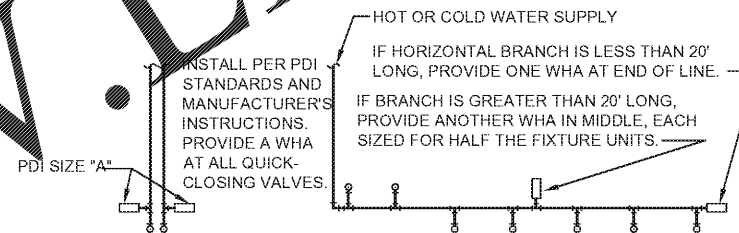

1 WATER HAMMER ARRESTERS
SCALE: NO SCALE

PDI SIZE	PIPE SIZE	FIXTURE UNIT LOAD
A	1/2"	1-11
B	3/4"	12-32
C	1"	33-60
D	1-1/4"	61-113
E	1-1/2"	114-154
F	2"	154-330

FIXTURE	COLD		HOT	
	VALVE	WHA	VALVE	WHA
VALVE WATER CLOSET	10	1	10	1
TANK WATER CLOSET	3	1	3	1
URNIAL	5	1	5	1
LAVATORY/SINK	2	1	2	1
SHOWER/BATHTUB	2	1	2	1

DO NOT PROVIDE AIR CHAMBERS. PROVIDE WATER HAMMER ARRESTERS BY SIOUX CHIEF, PRECISION PLUMBING PRODUCTS, WATTS OR APPROVED EQUIVALENT WITH PISTON AND O-RING CONSTRUCTION, HAVING PDI #WH-201, ASSE # 1010 AND ANSI # A112.26 1M CERTIFICATION. INSTALL IN HORIZONTAL OR VERTICAL POSITION, BUT NEVER UPSIDE DOWN. INSTALL IN LINE WITH WATER FLOW IF POSSIBLE. SIZE THE UNITS AS SHOWN ON THE DRAWINGS AND/OR PER THE TABLES SHOWN ABOVE. SIOUX CHIEF "MINI-RESTER" MAY BE USED AT EACH FIXTURE. PROVIDE ACCESSIBILITY TO "WHA" WHERE REQUIRED BY LOCAL CODE.

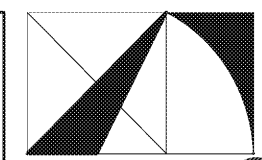

THE ARCHITECTURE GROUP, INC.

3775 Peachtree Lane S.E.
Atlanta, GA 30339
Phone: (678) 222-0375
Fax: (678) 222-0384
info@architecturegroup.com

COPYRIGHT © 2018 BY THE ARCHITECTURE GROUP, INC. ALL RIGHTS RESERVED.

THIS DRAWING MAY NOT BE USED IN ANY MANNER NOR REPRODUCED IN ANY FORM WITHOUT PRIOR WRITTEN CONSENT FROM THE ARCHITECTURE GROUP, INC.

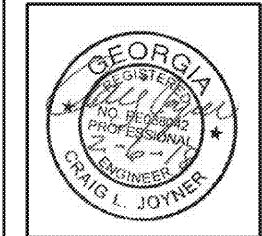

2018 MRRF CAMPUS-WIDE ADA IMPROVEMENTS
PROJECT No. IGSU-026-18
TAG PROJECT No. 1706
GEORGIA STATE UNIVERSITY
ATLANTA, GEORGIA

100% CDs	2/5/2017
REVISIONS	
DATE	2/5/2017
DRAWN BY	
CHECKED	
APPROVED	
SCALE	AS NOTED
PROJECT NUMBER	1706
DRAWING TITLE	

PLUMBING SCHEDULES AND DETAILS

DRAWING NUMBER

HH P0.2



Spencer Bristol Engineering, Inc.
A Gray Company
3577 Parkway Lane, Suite 250
Peachtree Corners, Georgia 30092
Tel. 770.414.1628 Fax 770.414.6024
SBE Project No. 1744