

- MISCELLANEOUS DECOR/FINISH NOTES:**
1. FIELD VERIFY ALL WALL DECOR DIMENSIONS PRIOR TO INSTALLATION. BRING ANY MAJOR DISCREPANCIES TO IMMEDIATE ATTENTION OF CLIENT PROJECT MANAGER.
 2. ALL FINISHED HVAC AND OPEN CEILING STRUCTURE ARE NOT PAINTED. PAINT COULDS BE APPLIED FROM FLOOR TO STEEL DECK. IF STORE IS AN EXPANSION OR RENOVEL, PAINT CEILING STRUCTURE TO MATCH EXISTING.
 3. CEILING, BRACES, & HVAC DUCTING THAT ARE ABOVE THE LIGHT LIME ARE NOT PAINTED.
 4. PAINT HVAC PARALLEL TO AND ATTACHED TO WALLS TO MATCH ADJACENT WALL COLOR.
 5. REMOVED: PAINT ALL MECHANICAL DUCTS THAT ARE ENTIRELY BELOW THE MAIN SALES AREA LIGHTING AND WITHIN 20" OF A WALL FT. BOSS. IF MECHANICAL DUCT THAT IS WITHIN 20" OF WALL RUNS VERTICAL TO BE BOTH ABOVE AND BELOW THE MAIN SALES LIGHTING, PAINT COLOR WALL TRANSITION 2" ABOVE LIGHTS. HIDE TRANSITION LINE. PAINT OVER STRUCTURE TO MATCH EXISTING.
 6. MARKETPLACE: DO NOT PAINT ANY MECHANICAL DUCTS OR PIPING.
 7. ALL HVAC WALL GRILLES TO BE PAINTED TO MATCH SURROUNDING WALL BACKGROUND COLOR, IF FEASIBLE, UNLESS OTHERWISE NOTED.
 8. REFER TO ARCHITECTURAL DRAWINGS FOR LAY IN CEILING COLOR AND COLUMN COLOR.
 9. ALL FINISHABLE DOORS VISIBLE TO CUSTOMERS TO BE PAINTED (UNLESS UNLESS FACTORY FINISHED, OR NOTED OTHERWISE).
 10. ALL BACKGROUND COLOR WALL FINISHES TO EXTEND 6" MINIMUM BEYOND LIGHT FIXTURES TO PERMANENT FIXTURES OF CASEWORK.
 11. ALL WALL PAINT FINISHES FROM FINISH FLOOR TO BE EGGSHELL. ALL PAINT FINISHES TO BE FLAT.
 12. END OF TILE RUNS AND OUTSIDE CORNERS TO RECEIVE SCHLUTER TRIM. REFER TO ARCHITECTURAL SPECIFICATIONS.
 13. ALL CORRIDORS TRAVELING BY CUSTOMERS (STOCKING ROOMS, RESTROOMS) TO RECEIVE WALL BASE. REFER TO ARCHITECTURAL SPECIFICATIONS FOR WALL FINISHES.
 14. ALL FRONT, BACK AND UNDER CLOSET TO BE LIMITED COLORS INDICATED ON THE PLAN. REFER TO ARCHITECTURAL SPECIFICATIONS FOR COORDINATE WALL COLORS.
 15. COLUMN FINISHES TO MATCH TO FINISH AND ARCHITECTURAL FINISH SPECIFICATIONS.
 16. DECOR AT 8' TO 10' TO DO NOT HIDE DECOR UNLESS NOTED OTHERWISE ON PLAN.
 17. REFER TO ARCHITECTURAL DRAWINGS FOR WALL AND FLOOR FINISHES. CONTRACTOR RESPONSIBLE FOR WALL AND FLOOR FINISHES. CONTRACTOR RESPONSIBLE FOR WALL AND FLOOR FINISHES. CONTRACTOR RESPONSIBLE FOR WALL AND FLOOR FINISHES. CONTRACTOR RESPONSIBLE FOR WALL AND FLOOR FINISHES.
 18. DECOR INSTALLATION CONTRACTOR TO SUPPLY AND INSTALL PAINT FOR STENOLED DECOR. CONTRACTOR RESPONSIBLE FOR WALL AND FLOOR FINISHES. CONTRACTOR RESPONSIBLE FOR WALL AND FLOOR FINISHES. CONTRACTOR RESPONSIBLE FOR WALL AND FLOOR FINISHES. CONTRACTOR RESPONSIBLE FOR WALL AND FLOOR FINISHES.
 19. REFER PROJECT MANAGER TO COORDINATE FINAL LOCATION OF SUSPENDED DECOR. REFER TO ARCHITECTURAL SPECIFICATIONS FOR COORDINATE WALL COLORS.
 20. THE CONTRACTOR RESPONSIBLE FOR THE DECOR INSTALLATION SHALL PROVIDE ALL SUPPORTS, CABLING, AND MISCELLANEOUS HARDWARE FOR DECOR INSTALLATION. CONTRACTOR RESPONSIBLE FOR THE DECOR INSTALLATION SHALL PAINT EXPOSED SUPPORTS, BRACKETS AND FASTENERS TO MATCH ADJACENT SURFACE. NOTHING TO BE ATTACHED TO BOTTOM OF FLOOR DECK OR CEILING GRID. ALL ATTACHMENTS OR CROSS MEMBERS FOR ATTACHMENT MUST BE FROM THE TOP CHORD OF JOIST.
 21. PAINT NON-GALVANIZED COLOR PAGES VISIBLE TO CUSTOMERS IN SERVICE FREE AREAS TO MATCH ADJACENT TILE OR GLAZING COLOR.
 22. PROVIDE 4" MINIMUM TRIM AROUND FITTING ROOM ENTRY OPENINGS AND TOP OF WALLS. FINISH TO MATCH ADJACENT WALL.

DESIGN FABRICATIONS
 EAST MANASSAS AVE.
 SUITE 100
 MANASSAS, VA 20108
 TEL: 703.740.4807
 FAX: 703.740.4809
 design@dfdesign.com

COPYRIGHT © 2017
 ALL DRAWINGS AND DESIGNS ARE THE SOLE PROPERTY OF DESIGN FABRICATIONS, INC. THESE DRAWINGS ARE NOT TO BE COPIED WITHOUT WRITTEN CONSENT FROM DESIGN FABRICATIONS, INC. THESE DRAWINGS WERE PREPARED EXCLUSIVELY FOR THIS PROJECT. IT IS ILLEGAL FOR UNAUTHORIZED PERSONS TO USE THESE DRAWINGS OR DESIGNS FOR ANY OTHER PROJECT.
 DO NOT SCALE DRAWINGS. USE FIGURED DIMENSIONS ONLY.

OVERHEAD DECOR PLAN

PROJECT NAME: KROGER GA-414
 PROJECT LOCATION: 4355 WASHINGTON RD., EVANS, GA

ISSUED FOR: 80% REVIEW
 DATE: 01/26/18

NO. REVISED BY DATE

DRAWN: AM
 CHECKED: SW
 SCALE: 3/32" = 1'-0"
 JOB NO.: 1711-03
 SHEET #

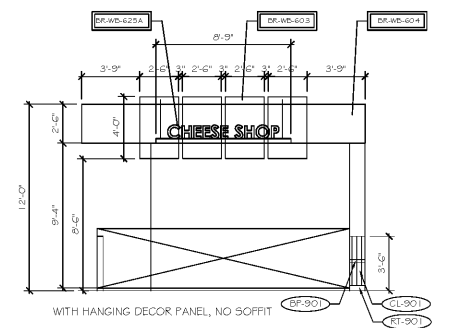

NOTE: DECOR PARTS NOT SHOWN. SITE VERIFY LOCATION

BR-DE-903	BR-DE-907	BR-DE-913	BR-DE-926
BR-DE-904	BR-DE-912	BR-DE-918	BR-DE-928
BR-DE-905	BR-DE-911	BR-DE-919	
BR-DE-906	BR-DE-910		

- VERIFY ARCHITECTURAL SPECIFICATIONS AND ADDITIONAL SUPPLEMENTAL SIGNAGE AND FINISH REQUIREMENTS NOT SHOWN ON DECOR DRAWINGS.
- CONTACT DECOR FABRICATOR WITH QUESTIONS REGARDING PARTS RECEIVED.
- LOCATION OF ALL DECOR TO BE SITE VERIFIED BASED ON MERCHANDISING.
- VERIFY BANNER LOCATIONS WITH RELAY OR PROJECT MANAGER BASED ON MERCHANDISING.
- INSTALLERS TO COORDINATE WINE RING INSTALLATION TO CLEAR HANGING POINTS WITH TRACK LIGHTING.

DECOR BY OTHERS - REFERENCE BEST PRACTICES

- KPNR
- KBAR (BABY)
- KOSD
- KPAR (PET)
- SWAS (NATURAL FOODS)

Order Plans

WWW.ONLINE.COM