



REVISIONS:

No.	Description	Date

PROJECT: 5202-169770  
DATE: January 2, 2018  
DRAWN BY: S.H.D.  
CHECKED BY: J.L.S.

SITE DETAILS

C-062

WWW.LDILine.com

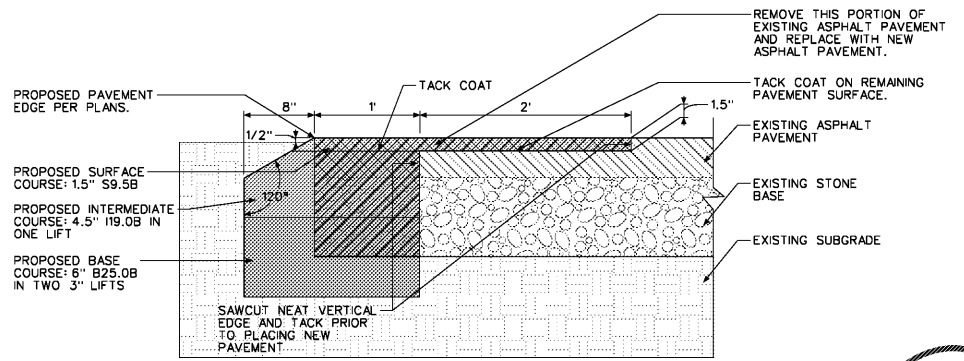

**B1** New Asphalt Edge at Existing Pavement

No Scale @

- NOTES:
1. THE MAXIMUM RAMP SLOPE SHALL BE 1:12 FOR ADA ROUTES AND 1:8 FOR OTHER PEDESTRIAN ROUTES. RAMP CROSS SLOPE SHALL BE 2% MAX.
  2. MAXIMUM LENGTH OF RAMPING BETWEEN LANDINGS SHALL BE THAT WHICH PROVIDES A MAXIMUM VERTICAL RISE OF 30". 30' @ 1:12, 20' @ 1:8. A 5' MINIMUM LENGTH LANDING MUST BE PROVIDED AT THE TOP AND BOTTOM OF EACH RAMP SECTION.
  3. LANDING SLOPES SHALL BE 2% MAX. LANDING CROSS SLOPES SHALL BE 2% MAX.
  4. FABRICATE HANDRAIL WITH CONTINUOUS WELDS, GRIND SMOOTH EDGES, AND PAINT TO PAINTING NOTE.
  5. HANDRAILS SHALL EXTEND HORIZONTALLY 12" BEYOND TOP OF RAMP AND 12" BEYOND BOTTOM OF RAMP.
  6. POSTS SHALL BE SPACED EQUALLY ALONG LENGTH OF RAMP AND SHALL BE GREATER THAN 36" O.C.
  7. PRIOR TO ANY HAND RAIL FABRICATION, FIELD MEASUREMENTS ARE TO BE TAKEN.

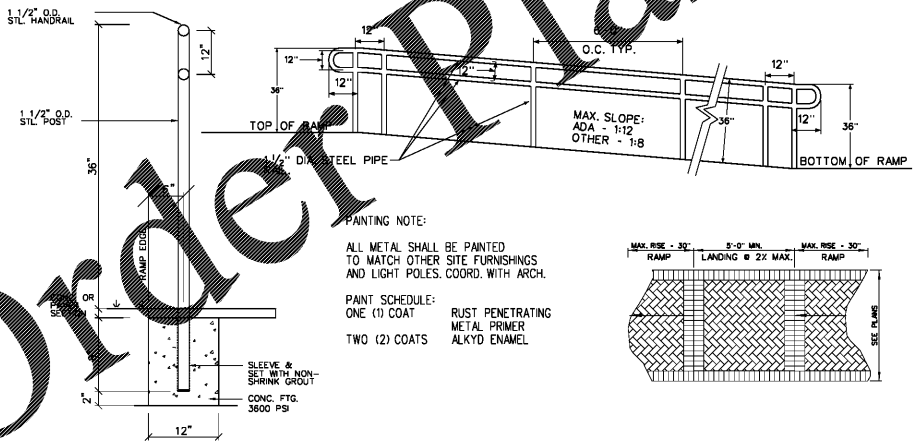

**A1** Ramp and Handrail Detail

**STAIR, RAMP, AND ACCESSIBILITY PATH VERIFICATION NOTES:**

CONTRACTOR SHALL PROVIDE A SEALED FINAL SURVEY FROM A LICENSED NC SURVEYOR OF ALL WALKS, RAMP, AND STAIRS TO VERIFY CONFORMANCE WITH NC BUILDING CODE AND ACCESSIBILITY REQUIREMENTS. THE SURVEY SHALL SPECIFICALLY ADDRESS, BUT NOT BE LIMITED TO, THE FOLLOWING ELEMENTS OF THE CODE:

STAIR RISER HEIGHTS SHALL BE 7 INCHES MAXIMUM AND 4 INCHES MINIMUM. STAIR TREAD DEPTHS SHALL BE 11 INCHES MINIMUM. THE RISER HEIGHT SHALL BE MEASURED VERTICALLY BETWEEN THE LEADING EDGES OF ADJACENT TREADS. THE GREATEST RISER HEIGHT WITHIN ANY FLIGHT OF STAIRS SHALL NOT EXCEED THE SMALLEST BY MORE THAN 0.375 INCH. THE TREAD DEPTH SHALL BE MEASURED HORIZONTALLY BETWEEN THE VERTICAL PLANES OF THE FOREMOST PROJECTION OF ADJACENT TREADS AND THE GREATEST TREAD DEPTH WITHIN ANY FLIGHT OF STAIRS SHALL NOT EXCEED THE SMALLEST BY MORE THAN 0.375 INCH.

RAMP SLOPES MAY NOT EXCEED A LONGITUDINAL SLOPE OF 1V:12H (ADA) OR 1V:8H (OTHER) OR EXCEED A VERTICAL CHANGE OF MORE THAN 2.5' BY ANY TOLERANCE.

ACCESSIBLE EGRESS PATHS AS IDENTIFIED ON SHEET C-010 SHALL NOT EXCEED A LONGITUDINAL SLOPE OF 1V:20H. A MIN. 4' LONG LANDING SHALL BE PROVIDED AT EACH EGRESS DOOR WITH SLOPES LESS THAN 2% IN ALL DIRECTIONS. ALL ACCESSIBLE PATHS SHALL HAVE A TARGETED CROSS SLOPE OF 1.5% AND SHALL NOT EXCEED 2% AT ANY LOCATION.

ANY WALKS, RAMP, OR STAIRS THAT ARE NOT IN COMPLIANCE SHALL BE REPLACED AT NO COST TO THE OWNER.

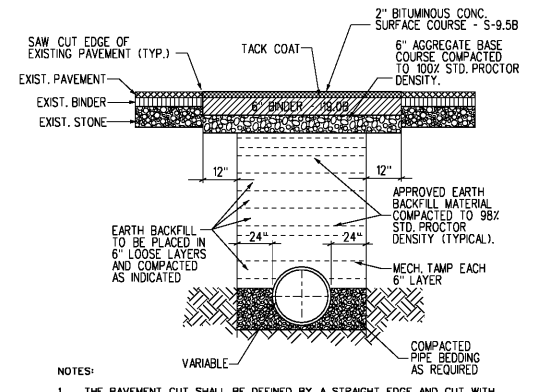

- NOTES:
1. THE PAVEMENT CUT SHALL BE DEFINED BY A STRAIGHT EDGE AND CUT WITH A SAWCUT MACHINE.
  2. THE ENTIRE THICKNESS AND VERTICAL EDGE OF CUT SHALL BE TACKED.
  3. THE ASPHALT PAVEMENT SHALL BE INSTALLED AND COMPACTED THOROUGHLY WITH A SMOOTH DRUM ROLLER TO ACHIEVE A SMOOTH LEVEL PATCH.
  4. NO HAND PATCHING ALLOWED.
  5. REFER TO DETAILS C2/C-060 AND C1/C-060 FOR TRENCHES AND PIPE BEDDING, RESPECTIVELY.

**A2** Pavement Patch

No Scale

19-DEC-2017 21:14  
PA\2017\2017\_05 Wilkes CC\DWG\CADD Files\wcc062.dgn