

REFER TO SHEET A0.3 FOR KEYNOTE SCHEDULE

TO THE FULLEST EXTENT POSSIBLE, COMPONENTS OF THE HALL SECTIONS WILL BE MARKED AS 'TYPICAL' (TYP.). WHERE SO, KEYED NOTES WILL NOT BE DUPLICATED FOR COMPONENTS OF LIKE KIND. SHOULD THE CONTRACTOR REQUIRE CLARIFICATION OF ANY SUCH COMPONENT, A REQUEST FOR INFORMATION (RFI) SHALL BE SUBMITTED TO THE ARCHITECT PRIOR TO BID

FWH
Architects
LIC.# AR0003300
333 Grand Blvd. Suite 201
Holiday, Florida 34690
Ph. 727. 815. 3336
Fax 727. 815. 3337

brightwork
FCBI Estimators
1700 WEST SWANN AVE. SUITE 300
TAMPA, FL 33609
PHONE: 813.874.1700

TO THE BEST OF THE KNOWLEDGE OF THE ARCHITECTS AND ENGINEERS, PLANS AND SPECIFICATIONS COMPLY WITH THE APPLICABLE MINIMUM BUILDING CODES AND THE APPLICABLE MINIMUM FIRE SAFETY STANDARDS

GUY F. FABER
FL License No. AR0015323

no.	date	revision descriptions

STARBUCKS
SHELL CONSTRUCTION
2500 MONUMENT ROAD
JACKSONVILLE, FL

12.13.17
date
17047
comm. no.

ENLARGED
PLAN DETAILS

A4.2

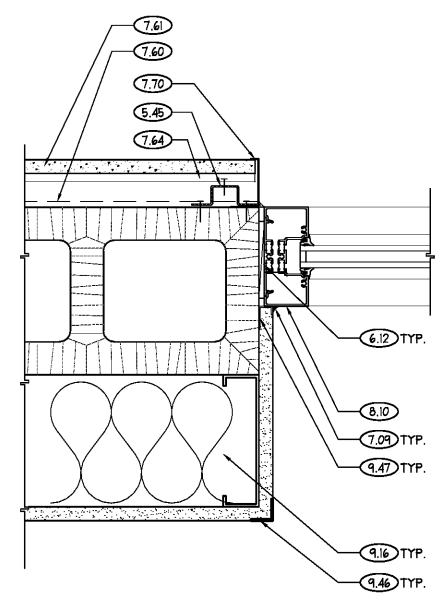

1 PLAN DETAIL
SCALE: 3" = 1'-0"

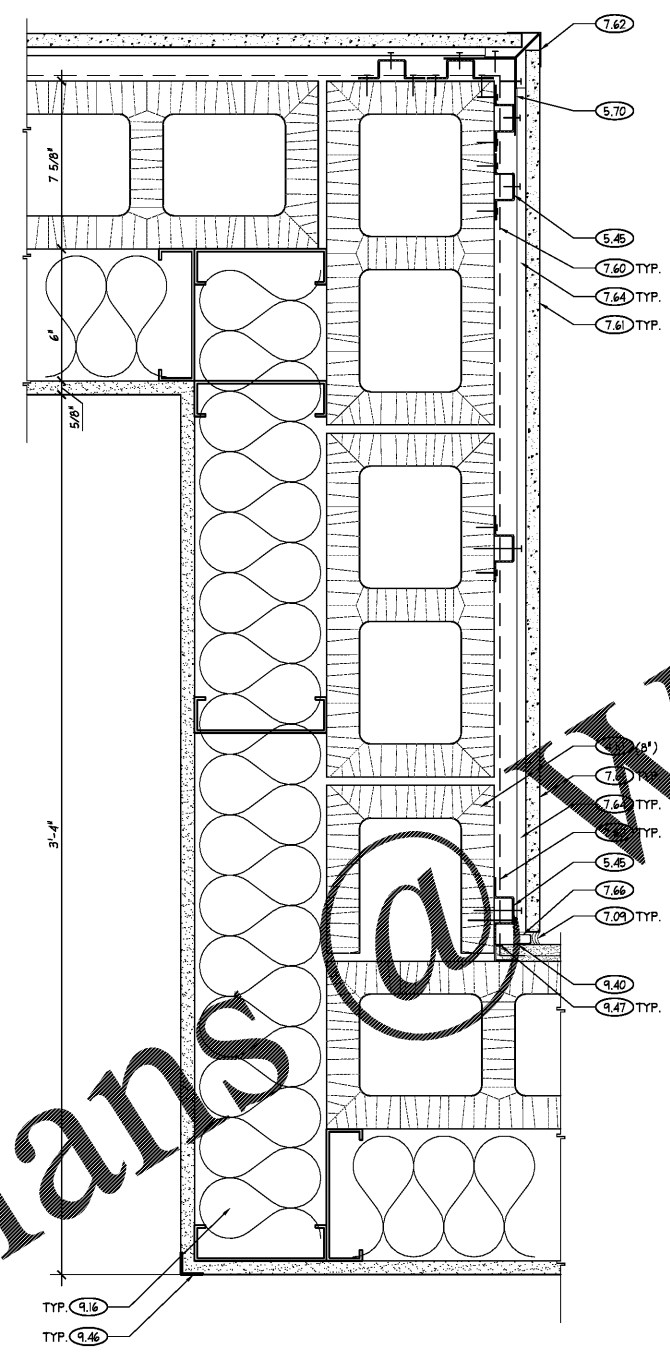

2 PLAN DETAIL
SCALE: 3" = 1'-0"

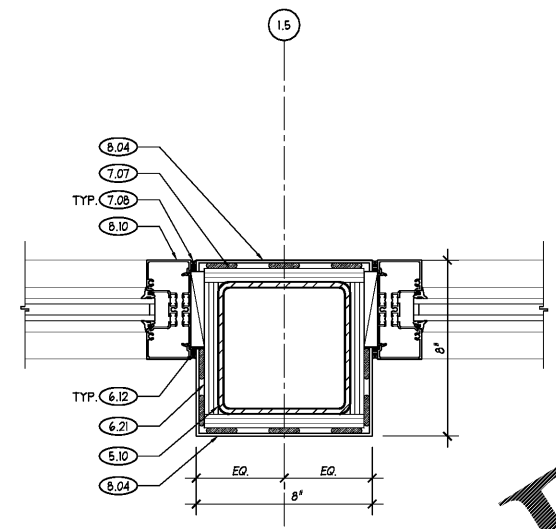

3 PLAN DETAIL
SCALE: 3" = 1'-0"

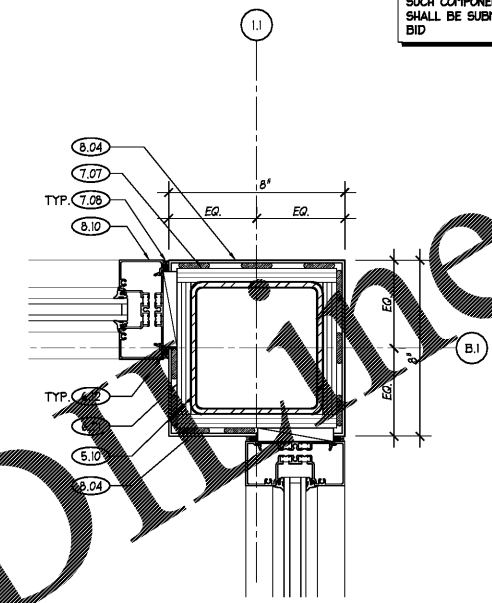

4 PLAN DETAIL
SCALE: 3" = 1'-0"

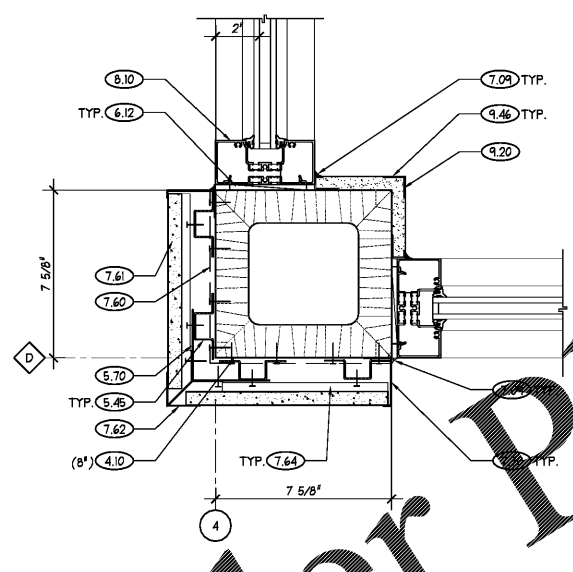

5 PLAN DETAIL
SCALE: 3" = 1'-0"

Order Plans