

1 STOREFRONT HEAD/ THRESHOLD DETAIL
SCALE: 3" = 1'-0"

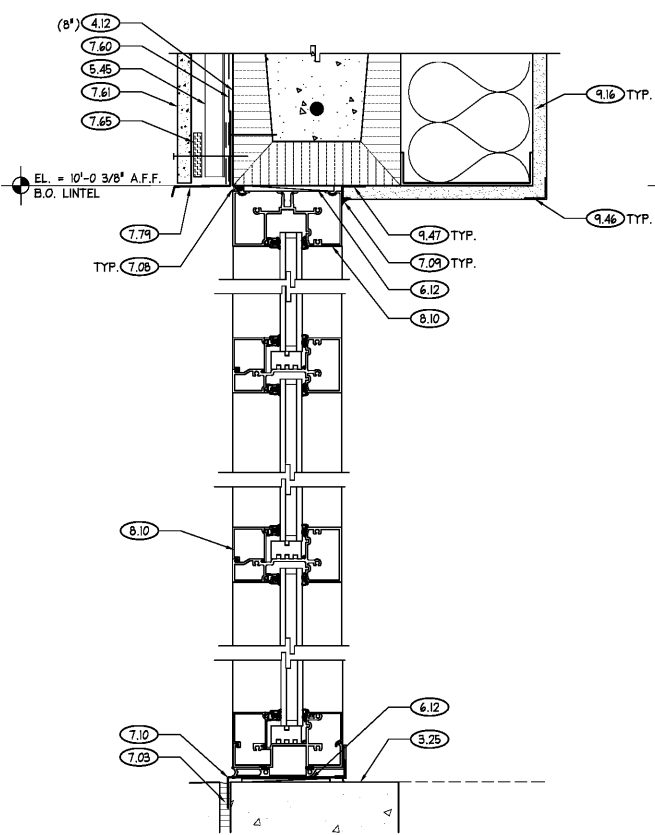

2 STOREFRONT HEAD/ SILL DETAIL
SCALE: 3" = 1'-0"

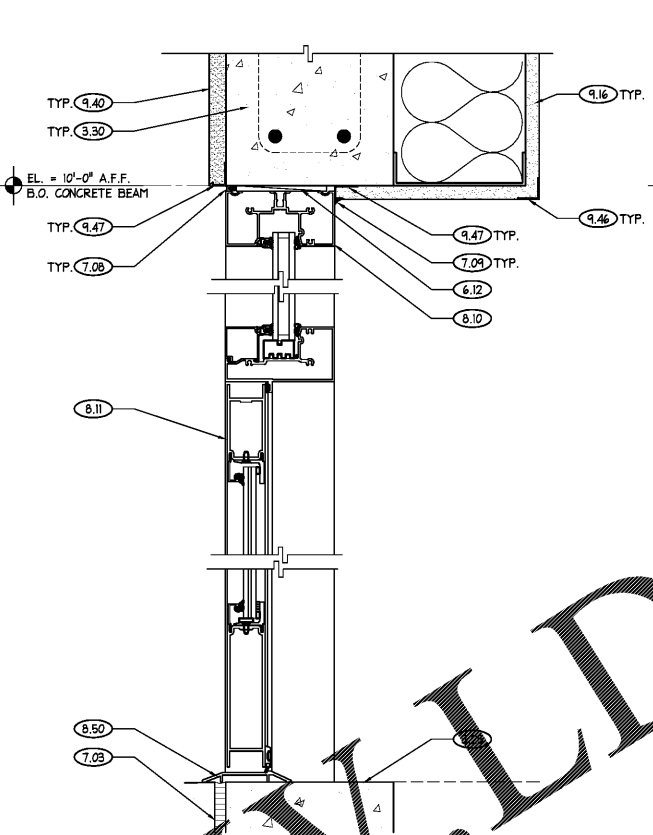

3 STOREFRONT HEAD/ THRESHOLD DETAIL
SCALE: 3" = 1'-0"

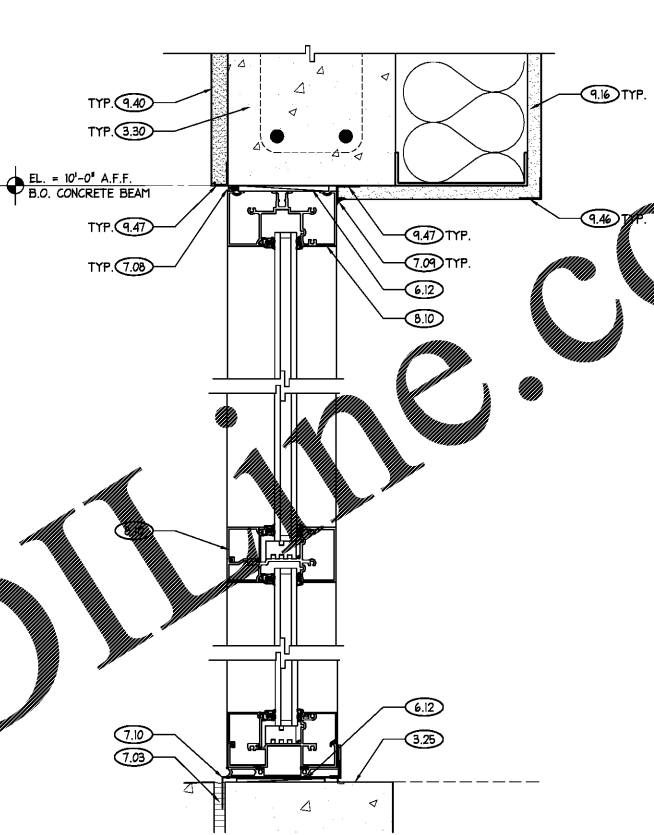

4 STOREFRONT HEAD/ SILL DETAIL
SCALE: 3" = 1'-0"

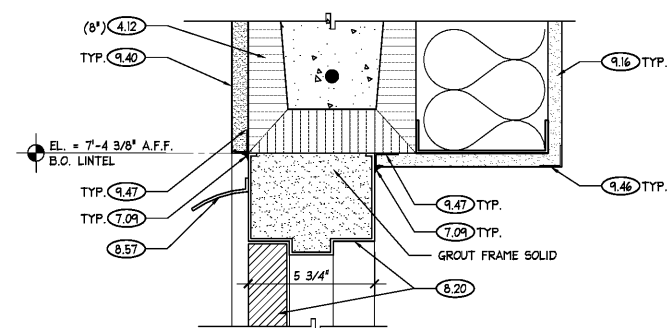

5 DOOR HEAD DETAIL
SCALE: 3" = 1'-0"

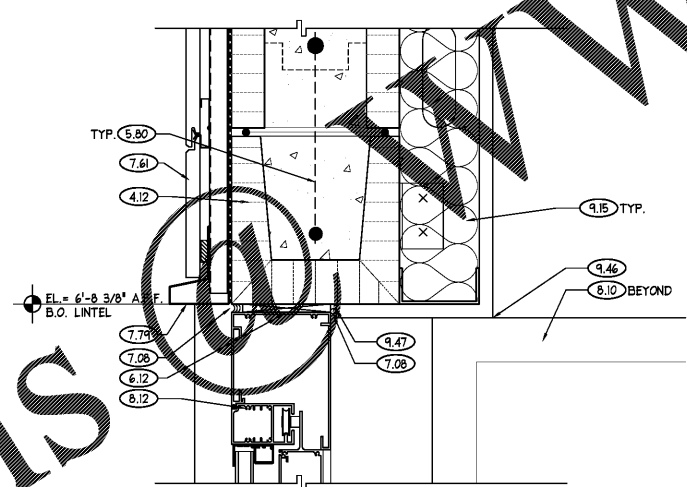

8 DRIVE-THRU HEAD DETAIL
SCALE: 3" = 1'-0"

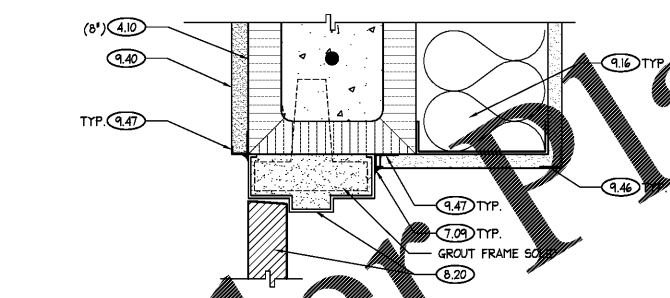

6 DOOR JAMB DETAIL
SCALE: 3" = 1'-0"

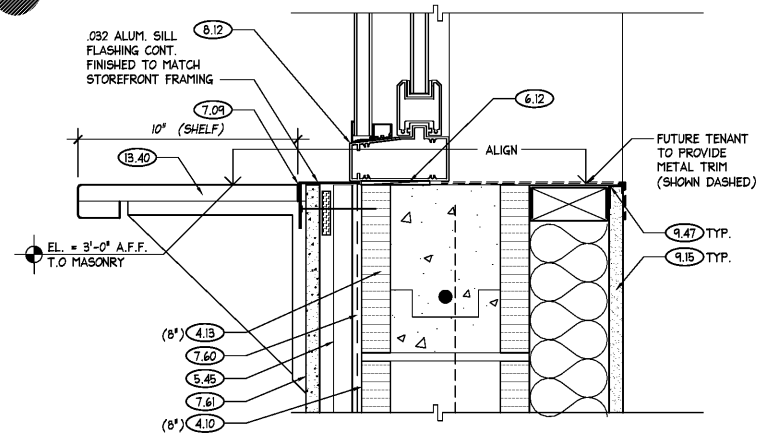

9 DRIVE-THRU SILL DETAIL
SCALE: 3" = 1'-0"

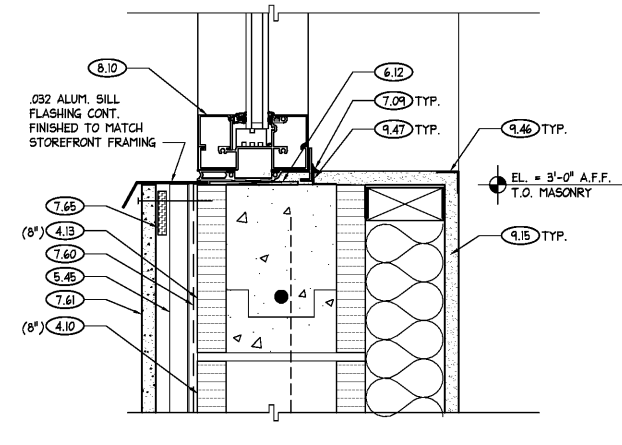

10 SILL DETAIL
SCALE: 3" = 1'-0"

Order Plans

7 ALUMINUM THRESHOLD DETAIL
SCALE: 3" = 1'-0"

REFER TO SHEET A0.3 FOR KEYNOTE SCHEDULE

TO THE FULLEST EXTENT POSSIBLE, COMPONENTS OF THE WALL SECTIONS WILL BE MARKED AS 'TYPICAL' (TYP.), WHERE SO, KEYNOTES WILL NOT BE DUPLICATED FOR COMPONENTS OF LIKE KIND. SHOULD THE CONTRACTOR REQUIRE CLARIFICATION OF ANY SUCH COMPONENT, A REQUEST FOR INFORMATION (RFI) SHALL BE SUBMITTED TO THE ARCHITECT PRIOR TO BID.

FWH Architects
Lic. # 00093000
335 Grand Blvd, Suite 201
Holiday, Florida 34690
Ph. 727. 815. 3336
Fax 727. 815. 3337

brightwork
FBI Est. # 170
1700 WEST SWANN AVE. SUITE 200
TAMPA, FL 33609
PHONE: 813.874.1700

TO THE BEST OF THE KNOWLEDGE OF THE ARCHITECTS AND ENGINEERS, PLANS AND SPECIFICATIONS COMPLY WITH THE APPLICABLE MINIMUM BUILDING CODES AND THE APPLICABLE MINIMUM FIRE SAFETY STANDARDS

GUY F. FABER
FL License No. AR0015323

no.	date	revision descriptions

STARBUCKS SHELL CONSTRUCTION
2500 MONUMENT ROAD
JACKSONVILLE, FL

12.13.17
date
17047
comm. no.

FRAME OPENING DETAILS

A4.1