

MISCELLANEOUS

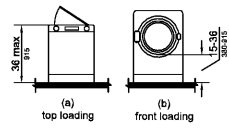

NOTE:
HANDRAILS MUST BE CONTINUOUS ON BOTH SIDES OF A STAIR.
ENDS OF HANDRAILS MUST EXTEND BEYOND THE STAIR AS SHOWN

HANDRAIL SECTIONS

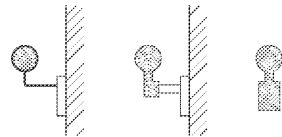

NOTE:
THE GRIPPING PORTION OF A HANDRAIL MUST BE EQUIVALENT
TO A 1-1/4" TO 1-1/2" (32 TO 38mm) DIAMETER ROUND RAIL.

1 HANDRAIL DETAILS
A6 SCALE: NTS

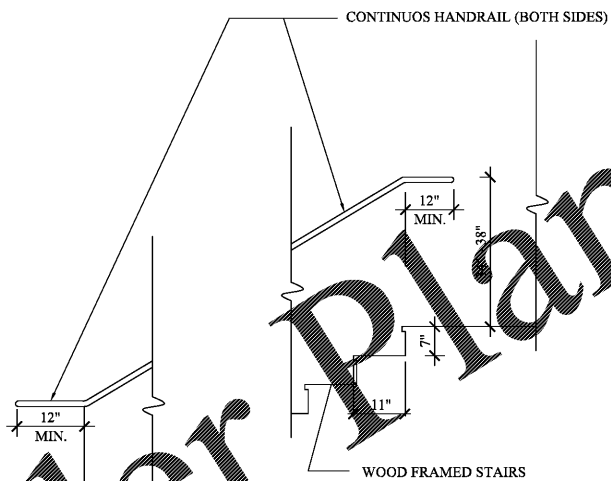

A6 STAIR DETAILS
SCALE: NTS

HANDRAILS & GRAB BARS

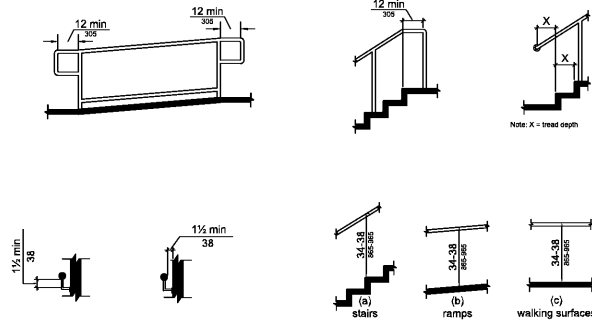

PLUMBING FIXTURES

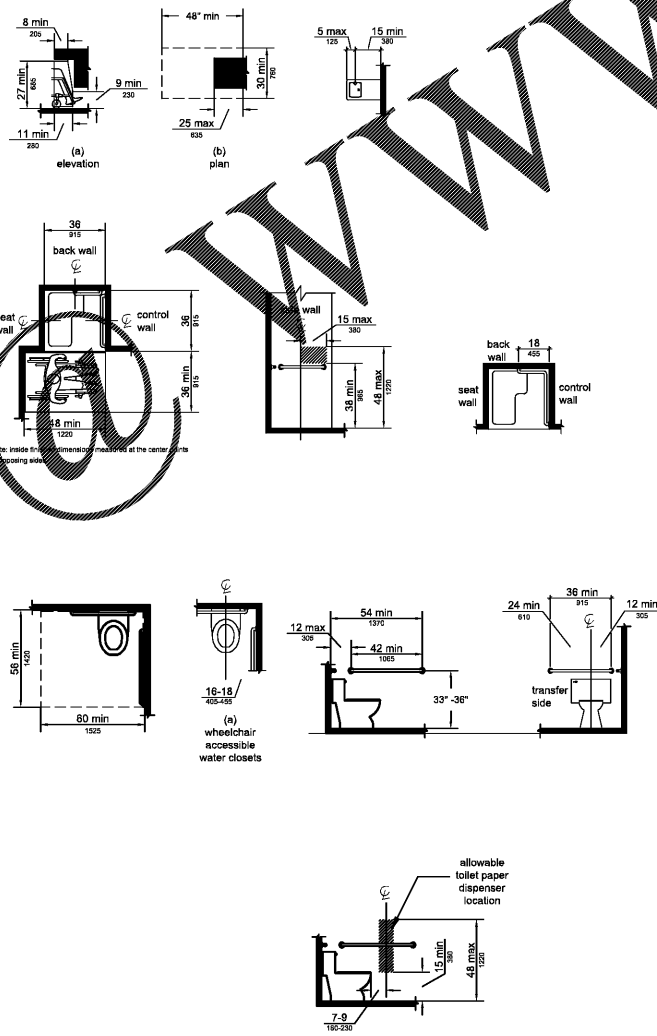

ACCESSIBLE ROUTE CLEARANCES

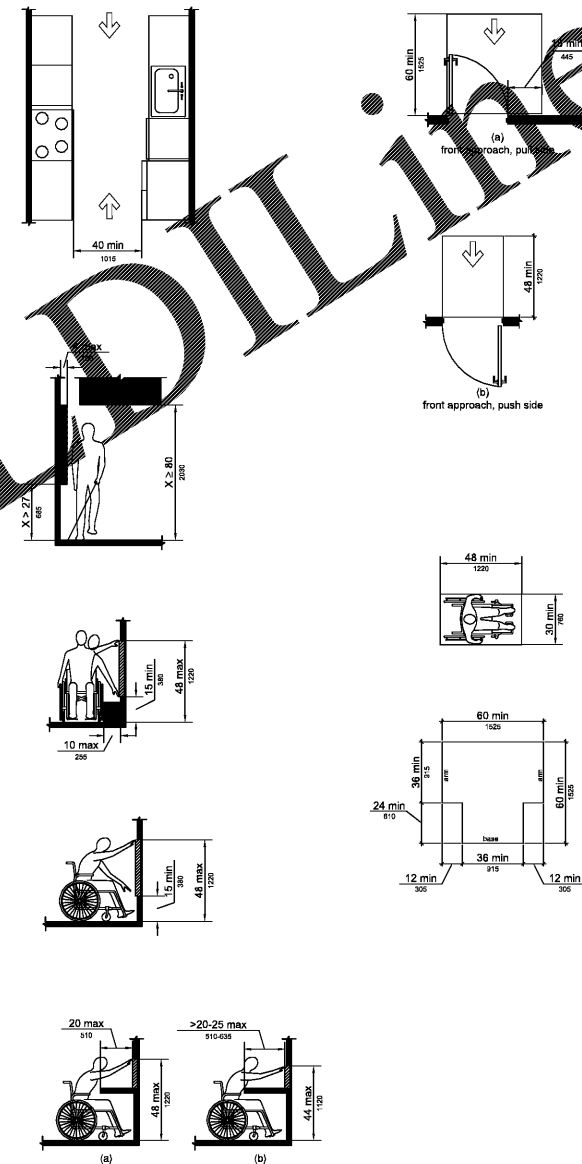

SIGNAGE & SYMBOLS

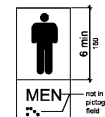

NOT ALL CONDITIONS MAY APPLY



REVISIONS

NO.	DATE

A
NEW TOWN
HALL FOR:

THE TOWN OF
NORTH
HIGH
SHOALS

260 HILLSBORO
ROAD

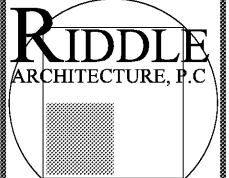

1481 HODGES MILL ROAD
BOGART, GA
30622
(404) 285-8646

TITLE: ACCESSIBILITY
DETAILS

JOB #: 1510
DATE: 11.17.17

SHEET #

A6

TYPICAL DETAILS - ALL CONDITIONS MAY NOT APPLY