

GENERAL NOTES:

- FOR INTERIOR FINISH SCHEDULE REFER TO INTERIOR DECOR DRAWINGS.
- NEW PLUMBING FIXTURES AND ACCESSORIES ARE TO BE PROVIDED BY G.C. EXCEPT SOAP DISPENSER, HAND SANITIZER & SEAT COVER DISPENSER WHICH ARE SUPPLIED BY VENDOR (ECOLAB) AND INSTALLED BY G.C.
- ALL PLUMBING FIXTURES, FAUCETS, AND ACCESSORIES (INCLUDING OWNER AND VENDOR SUPPLIED ITEMS) TO BE ADA COMPLIANT - SEE T1.3 & T1.4 FOR FURTHER CLARIFICATION - CONTACT THE ARCHITECT FOR CLARIFICATION ON ANY ITEMS THAT ARE UNCLEAR PRIOR TO INSTALLATION.**
- AT ALL INTERIOR TILE CORNERS & DOOR FRAME INTERSECTIONS LEAVE-OUT GROUT AND INSTALL SANDED SEALANT TO MATCH ADJACENT GROUT AS SOFT JOINT.

CONSTRUCTION KEY NOTES

- LAVATORY & FAUCET - ZURN -Z5314 KOHLER K-15510 W/ 70 TEMP. LIMITED DEVICE & ADA COMPLIANT TOWEL GUARD.
- TOILET - REPLACE W/ AMERICAN STANDARD 24670 "CANFJ" W/ LOCKING TANK AND BEAM LOCK.
- NEW RESTROOM SIGNAGE - SEE DETAIL INFORMATION ON THIS SHEET. PROVIDE AS SHOWN W/ WHITE LETTERING.
- FINAL CONNECTION TO EXISTING UTILITIES.

ACCESSORY LEGEND:

- GRAB BAR(S) - 36" REAR-WALL 42" SIDE-WALL & 18" VERTICAL - BOBRICK B5806 - CARRY CAPACITY 250 LBF.
- WALL MOUNTED SOAP DISPENSER & HAND SANITIZER DISPENSER - REMOVE & REPLACE WITH THOSE SUPPLIED BY ECOLAB AND INSTALLED BY G.C.
- MIRROR (BOTTOM OF REFLECTIVE SURFACE AT 40" MAXIMUM HEIGHT) - REUSE EXIST. IF POSSIBLE - IF REPLACEMENT REQUIRED USE: BOBRICK B-165-1836 (18"x36") W/ THEFT RESISTANT SCREWS.
- TOILET PAPER DISPENSER - SAN JAMAR - R4000TK.
- PAPER WASTE RECEPTACLE - BOBRICK B-3644. MOUNT BOTTOM @ 4" AFF. DIRECTLY BELOW TOWEL DISPENSER.
- PAPER TOWEL DISPENSER - SAN JAMAR - T1490TBK.
- TOILET SEAT COVER DISPENSER - G.C. TO INSTALL AS PROVIDED BY VENDOR.
- SANITARY NAPKIN DISPOSAL - BOBRICK B-270.
- TOILET PARTITION(S) - BOBRICK 1080/1180 DURALINE SERIES #EO-09; COLOR: BLACK. ADA COMPLIANT HARDWARE & COAT HOOK - BOBRICK MODEL #B-6716 - INSTALLED ON TOILET SIDE OF DOOR. MOUNT @ 48" TO TOP OF HOOK.

ADA RESTROOM SIGNAGE:

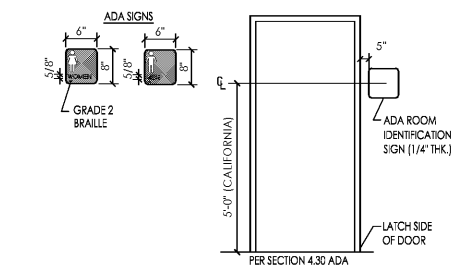

- CHARACTERS AND SYMBOLS SHALL CONTRAST WITH THEIR BACKGROUND.
- IDENTIFICATION SYMBOLS ARE TO BE ON THE WALL ADJACENT TO THE LATCH SIDE OF THE DOOR. MOUNT SIGN SO THAT THE BASELINE OF THE LOWEST TACTILE CHARACTERS ARE AT 48" MINIMUM, TO 60" MAXIMUM TO THE BASELINE OF THE HIGHEST TACTILE CHARACTERS.
- LETTERS & NUMBERS ON SIGNS SHALL BE RAISED 1/32" MIN., SHALL BE A MIN. OF 5/8" HIGH & SHALL BE SANS-SERIF UPPERCASE CHARACTERS. A.D.A. SIGNAGE ACCOMPANIED BY GRADE 2 BRAILLE.
- REGULATORY SIGNS TO BE TYPICALLY ADA COMPLIANT TACTILE 3-D PLAQUES PER CODE REQUIREMENTS.
- SIGNS TO BE A TYPICAL ONE PIECE INJECTION MOLDED FABRICATION WITH RAISED SECOND SURFACE GRAPHICS.
- SIGN TO BE A CUSTOM COLOR TO MATCH PMS 262C WITH WHITE GRAPHICS.
- BRAILLE SHOWN IS FOR PLACEMENT ONLY. USE CORRECT BRAILLE FOR SIGN PRODUCTION.
- 3D TACTILE PLAQUES CAN BE OBTAINED FROM: AMERICRAFT CORPORATION (SIGN LANGUAGE) 904 4TH STREET WEST PALMETTO, FL 34221 PH# 1-800-237-3984 FAX. # 1-813-723-2452

ADA MOUNTING HEIGHTS & DIMENSIONS

ITEMS	DIMENSION (INCHES)
TOP OF TOILET SEAT - HEIGHT AFF	17 - 19
TOILET FROM SIDE-WALL	16 - 18
GRAB BAR(S) - HORIZONTAL - HEIGHT AFF	32 - 36
GRAB BAR - VERTICAL - HEIGHT AFF	39 - 41
TOILET PAPER IN FRONT OF TOILET - DIST. FROM FRONT	7 - 9
NAPKIN DISPOSAL (AT WOMENS) - DIST FROM FRONT	12 MAX.
DISPENSER OR MIRROR HEIGHT (TO REFLECTIVE SURF.)	40 MAX.
LAVATORY / SINK RIM HEIGHT - HEIGHT AFF	34 MAX.
LAVATORY / SINK KNEE CLEARANCE - HEIGHT AFF	29 MAX.
URINAL LIP HEIGHT - AFF	17 MAX.
URINAL FLUSH HANDLE HEIGHT - AFF	44 MAX.

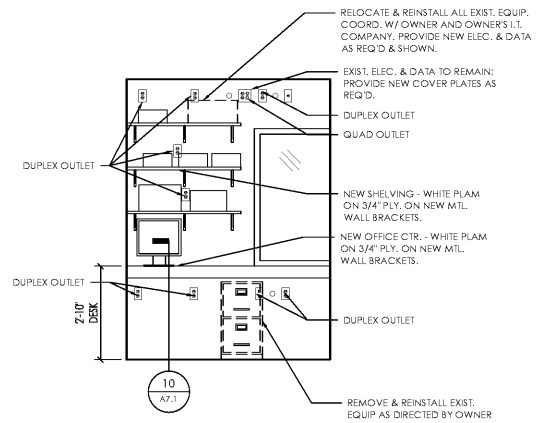

09 INT. ELEV @ OFFICE
A7.1 SCALE: 3/8"= 1'-0"

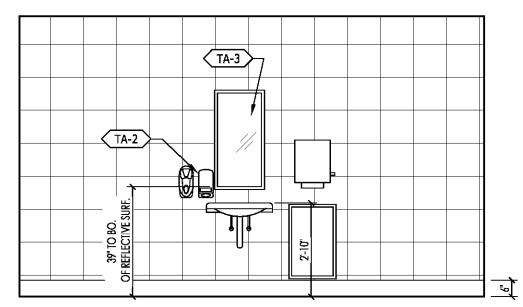

05 INT. ELEV @ WOMEN'S
A7.1 SCALE: 3/8"= 1'-0"

