

REVISIONS	DATE
ISSUE FOR CLIENT AND LANDLORD	10/27/2017
ISSUE FOR PERMIT	11/17/2017
ISSUE FOR BID - REV 1	11/27/2017

robert g. lyon + associates, inc.
 retail architecture
 5100 Schiller Park, IL 60176
 Schiller Park, IL 60176
 p: 847.671.7452
 f: 847.671.4200
 www.rgla.com

THE ABOVE DRAWINGS AND SPECIFICATIONS AND IDEAS, DESIGN AND ARRANGEMENTS REPRESENTED THEREIN ARE AND SHALL REMAIN THE PROPERTY OF THIS OFFICE AND NO PART THEREOF SHALL BE COPIED, DISCLOSED TO OTHERS OR USED IN THE CONNECTION WITH ANY WORK OR PROJECT OTHER THAN THE SPECIFIC PROJECT FOR WHICH THEY HAVE BEEN PREPARED AND DEVELOPED WITHOUT THE WRITTEN CONSENT OF THIS OFFICE. VISUAL CONTACT WITH THESE DRAWINGS OR SPECIFICATIONS SHALL CONSTITUTE CONCLUSIVE EVIDENCE OF ACCEPTANCE OF THESE RESTRICTIONS. WRITTEN DIMENSIONS ON THESE DRAWINGS SHALL HAVE PRECEDENCE OVER SCALED DIMENSIONS. CONTRACTORS SHALL VERIFY AND BE RESPONSIBLE FOR ALL DIMENSIONS AND CONDITIONS ON THE JOB AND THIS OFFICE MUST BE NOTIFIED OF ANY VARIATIONS FROM THE DIMENSIONS AND CONDITIONS SHOWN BY THESE DRAWINGS. SHOP DETAILS MUST BE SUBMITTED TO THIS OFFICE FOR APPROVAL BEFORE PROCEEDING WITH FABRICATION.
 ©2017 RGLA SOLUTIONS, INC.
 ©2017 ROBERT G. LYON & ASSOCIATES, INC.

THE NORTH FACE
 AVENTURA MALL
 19501 BISCAYNE BLVD
 SPACE #327
 AVENTURA, FL 33180

FIXTURE DETAILS

DRAWN BY	AC
CHECKED BY	KK
JOB NUMBER	17183
SHEET NAME	A-3.2

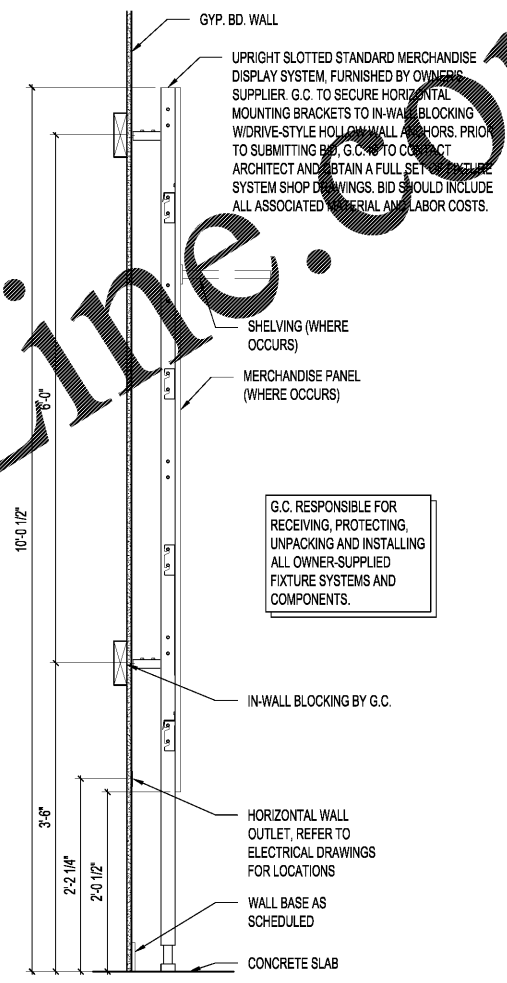

3 PERIMETER SYSTEM DETAIL

SCALE
1"=1'-0"

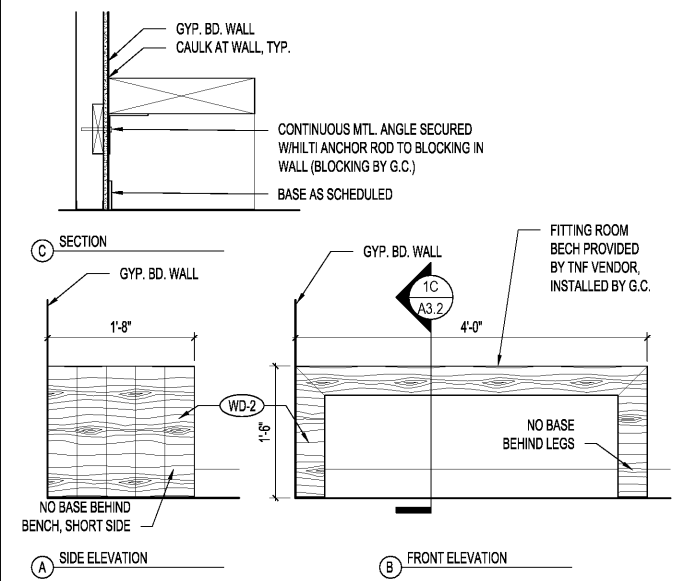

1 FITTING ROOM BENCH DETAIL

SCALE
1"=1'-0"

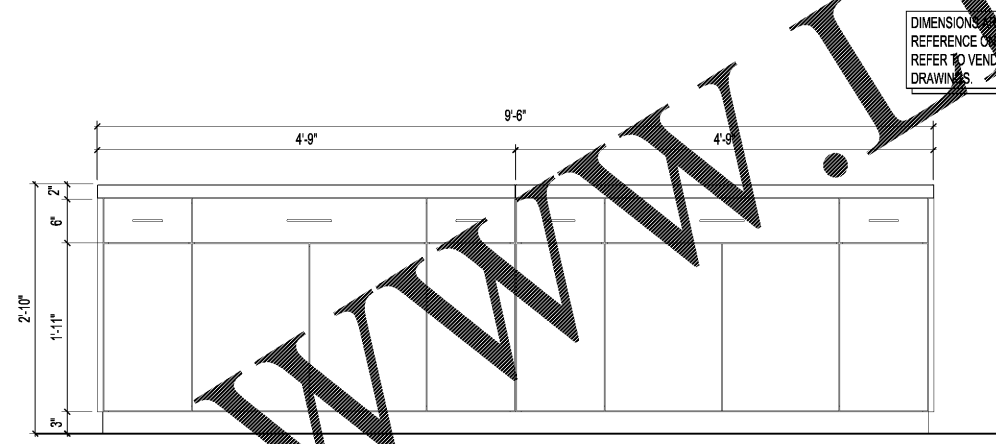

D BACKWRAP ELEVATION

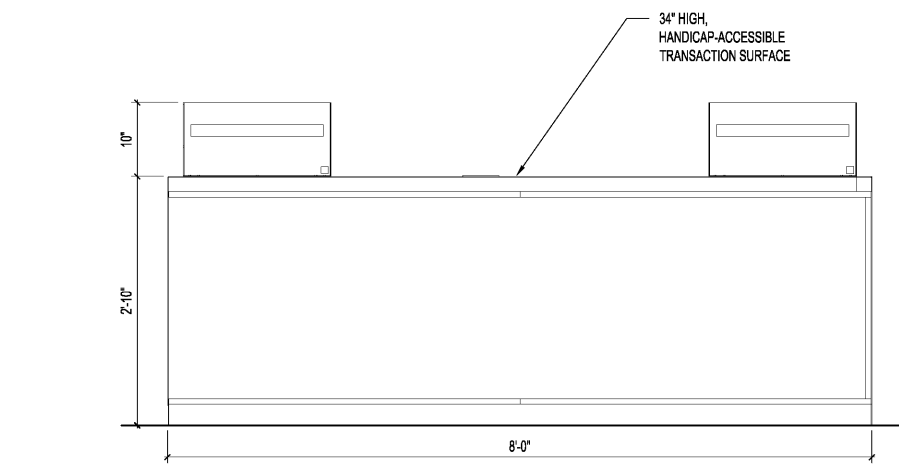

B FRONT CASHWRAP ELEVATION

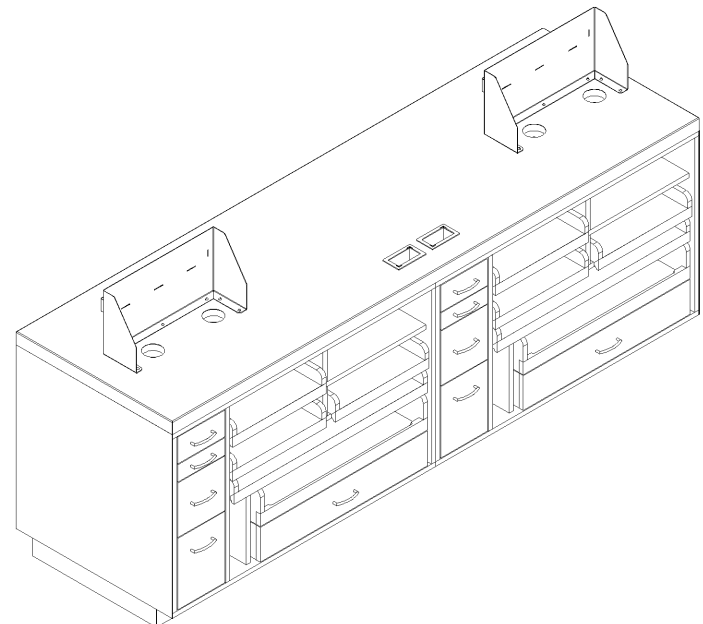

C REAR CASHWRAP ISOMETRIC
N.T.S.

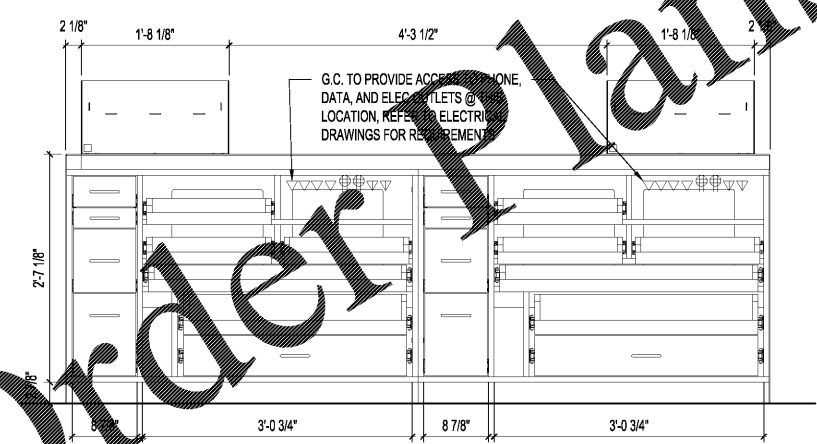

A REAR CASHWRAP ELEVATION

2 CASHWRAP/BACKWRAP DETAILS

SCALE
1"=1'-0"

Order Plans

WWW.LDILINE.COM