

Project
 Sam's Mart
 E. Independence Blvd.
 Indian Trail, NC 28097

Owner
 Sam's Mart
 7930 South Place
 Suite 100
 Matthews, NC 28105

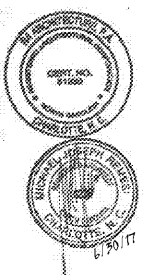

R4
 ARCHITECTURE, P.A.

124 Floyd Smith Dr
 Suite 375
 Charlotte, NC 28262
 Tel - 704 - 688-7500

2000 Sam Rittenburg Blvd
 Suite 116
 Charleston, SC 29407
 Tel - 843 - 531-6848

www.R4architecture.com

Revision Date

Drawn By TRB
Checked By MJR
Issue Date 06-30-17
Project No 160345

Sheet Title
 SECTION DETAILS

Sheet Number
A426

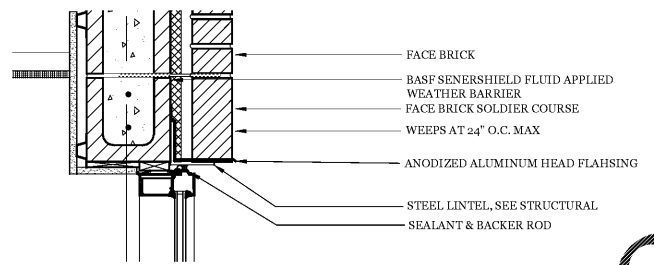

5 **DETAIL: STOREFRONT WINDOW SILL**
 3" = 1'-0"

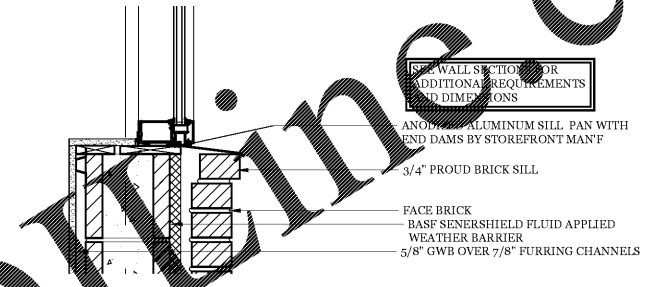

4 **DETAIL: STOREFRONT WINDOW SILL**
 3" = 1'-0"

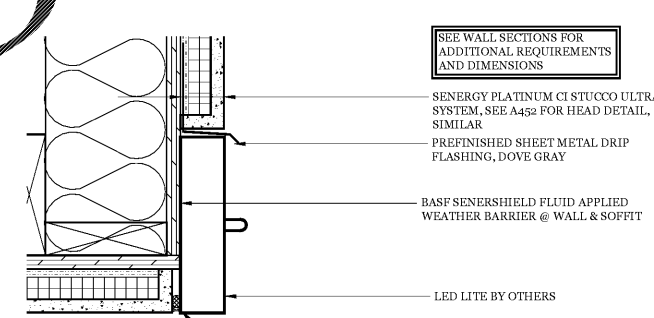

3 **DETAIL: LED ACCENT LITE**
 3" = 1'-0"

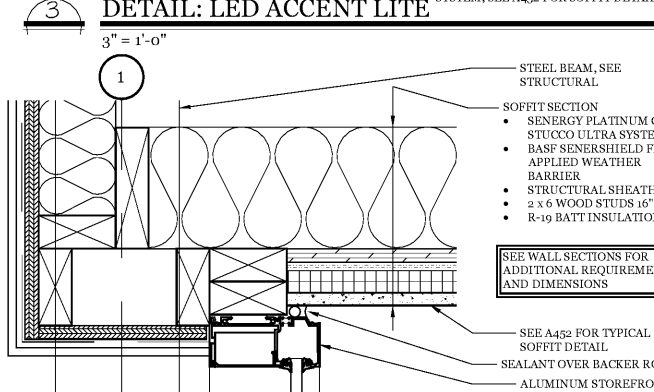

1 **DETAIL: STOREFRONT SILL**
 3" = 1'-0"

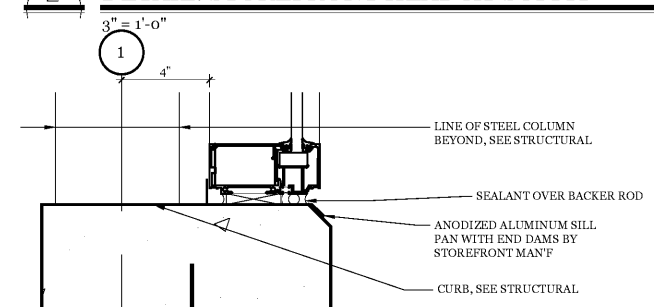

2 **DETAIL: STOREFRONT HEAD AT SOFFITT**
 3" = 1'-0"

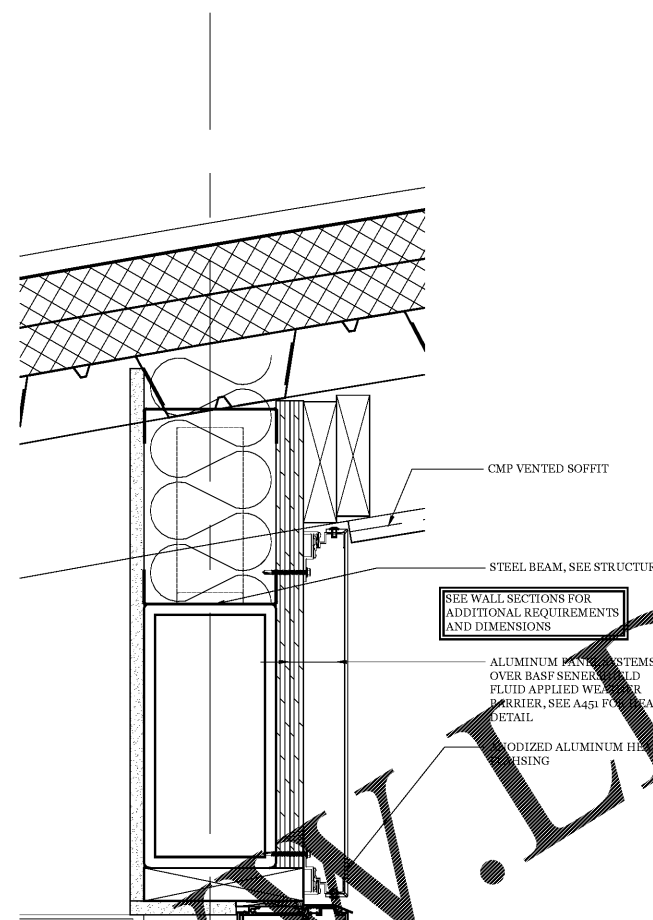

8 **DETAIL: HEAD AT ALUM. PANEL**
 3" = 1'-0"

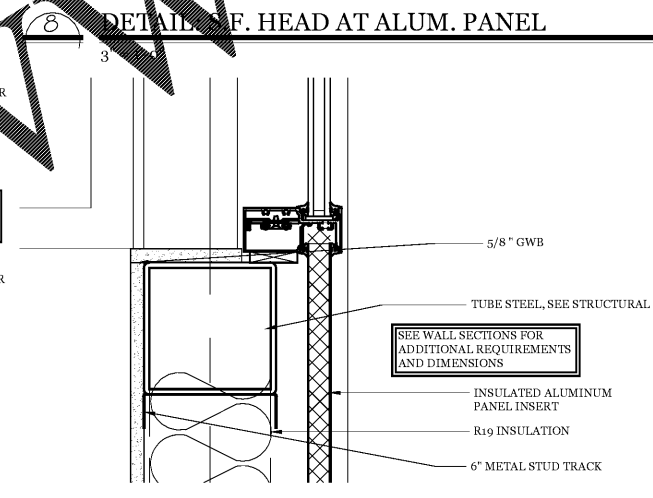

7 **DETAIL: STOREFRONT SILL AT INSERT**
 3" = 1'-0"

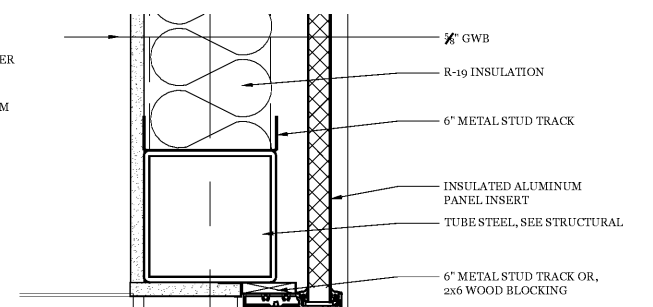

6 **DETAIL: STOREFRONT HEAD AT ALUM. PANEL**
 3" = 1'-0"

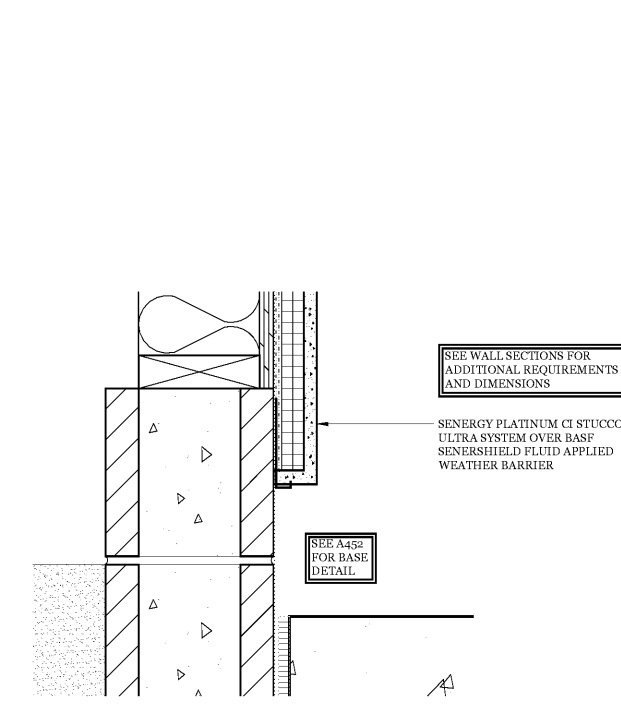

12 **DETAIL: STUCCO TERMINATION**
 3" = 1'-0"

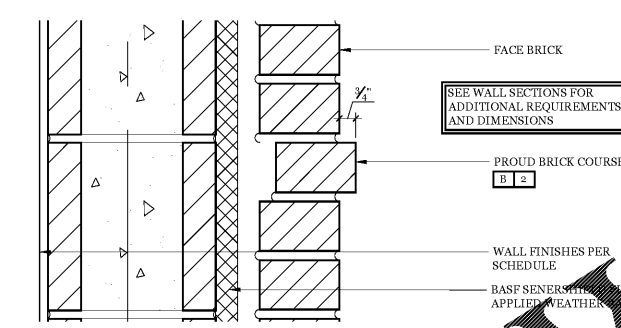

11 **DETAIL: PREFINISHED COPING, TYPICAL**
 3" = 1'-0"

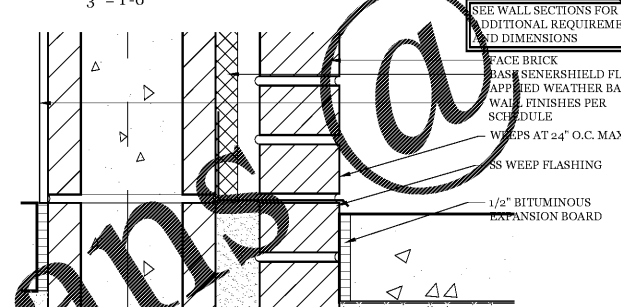

9 **DETAIL: STOREFRONT SILL**
 3" = 1'-0"

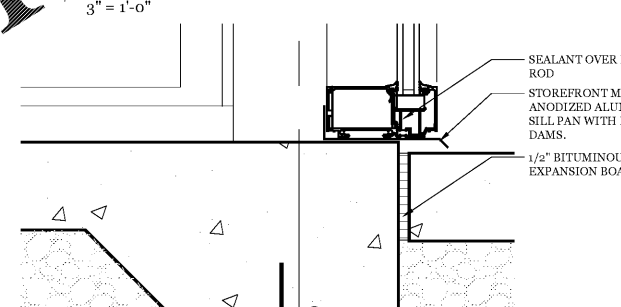

13 **DETAIL: PREFINISHED COPING, TYPICAL**
 3" = 1'-0"

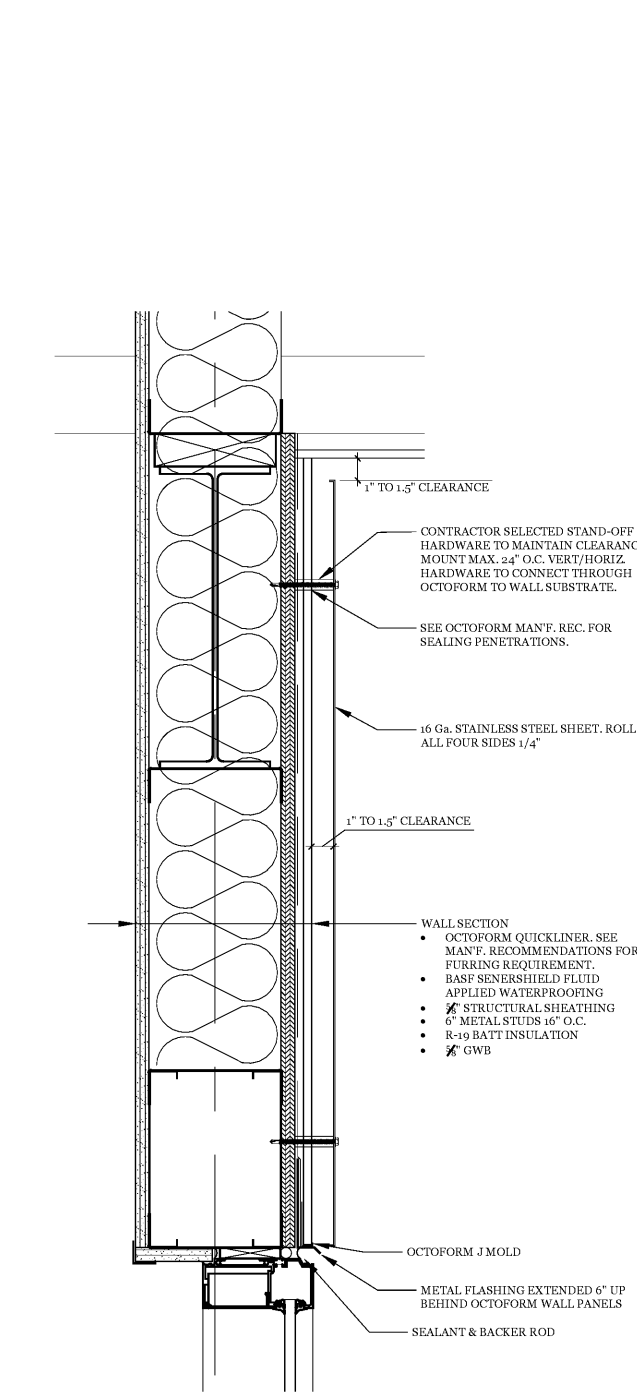

14 **DETAIL: HEAT SHIELD AT WASH WINDOW**
 3" = 1'-0"

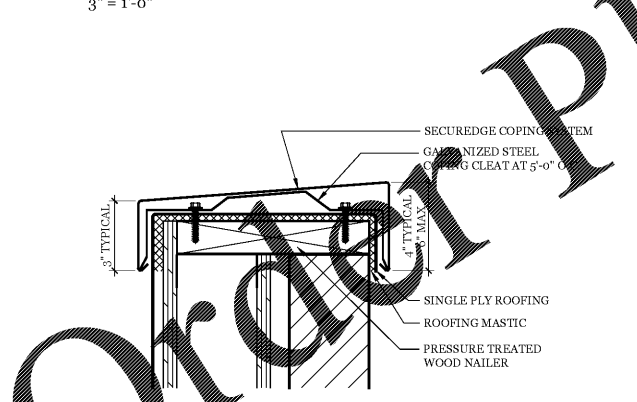

10 **DETAIL: BRICK AT PAVING**
 3" = 1'-0"

13 **DETAIL: PREFINISHED COPING, TYPICAL**
 3" = 1'-0"

9 **DETAIL: STOREFRONT SILL**
 3" = 1'-0"

NOTES
 1. INSTALLATION TO BE COMPLETED IN ACCORDANCE WITH THE MANUFACTURERS SPECIFICATIONS.
 2. DETAIL BASED ON CARLISLE SECUREDGE 300 PARAPET WALL COPING.
 3. APPROVED.

Order Plans